

GENERAL NOTES

- CHEEK WALLS**
 - CHEEK WALLS ARE PERMITTED WHEN ADJACENT TO NON-WALK AREAS OR ELEVATION DIFFERENCES CANNOT BE ACCOMMODATED BY FLARES OR GRADING.
- CROSSWALKS**
 - FOR CURB RAMPS THAT LEAD TO A SINGLE CROSSWALK, THE RAMP (EXCLUDING FLARES) TO BE FULLY INSIDE OF MARKED CROSSWALK LINES.
 - SHOULD BE PLACED A MINIMUM DISTANCE OF 4'-0" FROM STOP AND YIELD LINES.
 - FOR UN-SIGNALIZED AREAS, CROSSWALKS SHOULD BE PLACED A MINIMUM DISTANCE OF 20'-0" AWAY FROM ON ROAD PARKING ZONES. FOR SIGNALIZED AREAS, CROSSWALKS SHOULD BE PLACED A MINIMUM DISTANCE OF 30'-0" FROM ON ROAD PARKING ZONES.
 - PEDESTRIAN CROSSWALK IS 6'-0" MINIMUM.
 - USE LONGITUDINAL LINES AT 6'-0" LONG AND 2' WIDE WITH A SPACING OF 2' APART. SPACING SHOULD BE DESIGNED SO THE PAINTED AREAS AVOID THE WHEEL PATHS.
- CURB RAMPS**
 - CONSTRUCT CURB RAMPS WITH A MINIMUM 4'-0" X 4'-0" CLEAR SPACE BEFORE THE CURB FACE, WITHIN THE WIDTH OF THE CROSSWALK.
 - SLOPES THAT EXCEED 8.00%, OR CONTRACT DOCUMENTS AS APPLICABLE, WILL NOT BE ACCEPTED AND WILL BE RECONSTRUCTED.
 - PROVIDE SLIP RESISTANT TEXTURE ON CURB RAMP BY COARSE BROODING TRANSVERSE TO THE SLOPE OF THE RAMP. EXTEND TEXTURE THE FULL WIDTH AND LENGTH OF THE CURB RAMP INCLUDING FLARED SIDE RAMPS.
 - DO NOT EXCEED 2.00% CROSS SLOPE ON THE CURB RAMP OR PEDESTRIAN ACCESSIBLE ROUTE (MEASURED PERPENDICULAR TO THE DIRECTION OF TRAVEL).
 - CURB RAMP WIDTH IS 4'-0" MINIMUM.
 - ALL SLOPES ARE MEASURED WITH RESPECT TO A LEVEL PLANE. THEREFORE, THE LENGTH OF RAMP IS NOT SOLELY DEPENDANT ON THE HEIGHT OF CURB. (FOR EXAMPLE, A 6" CURB DOES NOT NECESSARILY MEAN A RAMP LENGTH OF 6'-0" FOR A 12:1 SLOPE.
 - THE CHANGE IN GRADE AT THE BOTTOM OF THE CURB RAMP AND ADJOINING ROAD SURFACE IS NOT TO EXCEED AN ALGEBRAIC DIFFERENCE OF 11.00%. THE COUNTER SLOPE OF THE GUTTER OR ROAD AT THE FOOT OF A CURB RAMP, TURNING SPACE OR BLENDED TRANSITION IS NOT TO EXCEED 8.00% AND IT IS NOT NECESSARY TO HAVE THE LENGTH GREATER THAN 15'-0".
 - FOR BLENDED TRANSITION CURB RAMPS (TYPE 3), THE MAXIMUM RUNNING SLOPE IS 5% WITH A MAXIMUM 2% CROSS SLOPE.
- FLUSH CURB**
 - CONSTRUCT TOP OF PLAIN CEMENT CONCRETE FLUSH CURB TO BE FLUSH WITH ADJACENT SURFACES (RAMPS, SIDEWALKS, FLARES).
 - CONSTRUCT FLUSH CURB FOR CURB RAMPS FLUSH TO ADJACENT ROADWAY. GRADE EDGE OF ROAD ELEVATIONS AT THE FLOW LINE TO ENSURE POSITIVE DRAINAGE AND PREVENT PONDING. THE VERTICAL ALIGNMENT OF A CURB RAMP, EXCLUDING FLARES, SHALL BE PLANAR. GRADE BREAKS SHALL BE FLUSH AND PERPENDICULAR TO THE DIRECTION OF THE RAMP RUN. RAMP TRANSITIONS BETWEEN WALKS, GUTTERS, TURNING SPACES, OR STREETS SHALL BE FLUSH AND FREE OF ABRUPT VERTICAL CHANGES (1/4" MAXIMUM).
 - FOR TYPE 3 RAMPS AND BLENDED TRANSITIONS, THE FLUSH CURB MUST EXTEND FROM THE OUTER MOST EDGE OF EACH CROSSWALK.
- DETECTABLE WARNING SURFACES**
 - NO SEPARATION BETWEEN DETECTABLE WARNING SURFACES FOR MEDIANS LESS THAN 4'-0" BETWEEN BACK OF CURBS.
 - PROVIDE DETECTABLE WARNING SURFACES (DWS) 24" MINIMUM (IN THE DIRECTION OF PEDESTRIAN TRAVEL) ACROSS FULL WIDTH OF RAMP AT THE GRADE BREAK NEAR STREET EDGE. PROVIDE DWS THAT CONTRAST VISUALLY WITH ADJACENT WALKWAY SURFACES, EITHER LIGHT-ON-DARK OR DARK-ON-LIGHT FOR THE FULL WIDTH OF RAMP.
 - ALIGN DETECTABLE WARNING SURFACE TRUNCATED DOMES ON A SQUARE GRID IN THE PREDOMINANT DIRECTION OF THE RAMP AND PERPENDICULAR TO CURB WHEN APPROPRIATE.
 - THE PUBLIC SIDEWALK CURB RAMP, DETECTABLE WARNING SURFACES (SHADED AREA) SHALL BE SAFETY RED COLOR, EXCEPT IF THE MUNICIPALITIES HAVE ESTABLISHED AN ALTERNATIVE COLOR SCHEME.
 - FOR TYPE 3 RAMPS AND BLENDED TRANSITIONS, THE DETECTABLE WARNING SURFACE MUST BE PLACED ALONG THE ENTIRE FLUSH CURB AND THE DOMES MUST BE PLACED IN SUCH A WAY THAT THE DIRECTION OF TRAVEL IS ORIENTED INTO THE CROSSWALK.
- DRIVEWAYS**
 - 6.00 % MAXIMUM SLOPE FOR THE DRIVEWAY APRON.
 - 1 1/2" MAXIMUM VERTICAL CHANGE IN HEIGHT BETWEEN THE ROAD SURFACE AND THE DEPRESSED CURB AT THE DRIVEWAY APRON.
- JOINTS**
 - PROVIDE EXPANSION JOINT MATERIAL 1/2" THICK WHERE CURB RAMP ADJOINS ANY RIGID PAVEMENT, SIDEWALK OR STRUCTURE WITH THE TOP OF JOINT FILLER FLUSH WITH ADJACENT CONCRETE SURFACE.
 - SEAL JOINTS WITH AN APPROVED SEALING MATERIAL.
- TURNING SPACES**
 - TURNING SPACE, APPROACH SIDEWALK TRANSITIONS, AND CURB RAMP SHALL BE KEPT CLEAR OF OBSTRUCTIONS, UNLESS AN EXCEPTION IS GRANTED.
 - DO NOT EXCEED 2.00% FOR RUNNING AND CROSS SLOPES.
 - TURNING SPACE SHOULD BE 4'-0" X 4'-0" MINIMUM CLEAR SPACE. IF THE TURNING SPACE IS CONSTRAINED ON 2 OR MORE SIDES, IT MUST BE 4'x5' WITH THE 5' LENGTH ALONG THE UNOBSTRUCTED SIDE. FOR TYPE 3 RAMPS AND BLENDED TRANSITIONS, THE TURNING SPACE MUST HAVE A MINIMUM OF A 5'-0" DEPTH (INCLUDING THE DETECTABLE WARNING SURFACE) ALONG THE FLUSH CURB/ROADWAY.
 - 4'x4' TURNING SPACES ARE REQUIRED AT EVERY ACCESSIBLE PEDESTRIAN SIGNAL/PUSH BUTTON LOCATION.
 - TURNING SPACES SHALL BE CONSTRUCTED AT THE TOP OF EVERY PERPENDICULAR RAMP AND AT THE BOTTOM OF EVERY PARALLEL RAMP.

- NON-WALK SURFACES**
 - NON-WALK AREA IS AN OBSTRUCTION OR GRASS/NON-PAVED AREA ADJACENT TO THE PEDESTRIAN ACCESS ROUTE THAT IS NOT USED BY THE PEDESTRIAN FOR ACCESS.
- PEDESTRIAN PUSH BUTTONS**
 - THE DETAILS DEPICT PEDESTRIAN PUSH BUTTON POLES TO ILLUSTRATE THE RECOMMENDED PLACEMENT OF PEDESTRIAN PUSH BUTTONS. FOR ALTERATION PROJECTS, PROVIDE ACCESS TO EXISTING PEDESTRIAN PUSH BUTTONS TO THE MAXIMUM EXTENT FEASIBLE. INSTALL PEDESTRIAN PUSH BUTTON STUB POLES, WHERE APPLICABLE, SO AS NOT TO CREATE PEDESTRIAN OBSTRUCTIONS.
 - PUSH BUTTON LOCATION SHALL BE COMPLIANT WITH THE CURRENT MUTCD.
 - ADJACENT TO A LEVEL NON-SLIP SURFACE TO PROVIDE ACCESS FROM A WHEELCHAIR, AND WHERE THERE IS A NON-SLIP WHEELCHAIR ACCESSIBLE ROUTE TO THE RAMP
 - WITHIN 5'-0" OF THE CROSSWALK EXTENDED
 - BETWEEN 1'-6" AND 10'-0" OF THE EDGE OF CURB, SHOULDER OR PAVEMENT
 - PARALLEL TO THE CROSSWALK TO BE USED
 - MOUNT PEDESTRIAN PUSH BUTTON 42" ABOVE THE SIDEWALK OR FINISHED GRADE TO THE CENTER OF THE PUSH BUTTON AND 10" MAXIMUM Laterally FROM TURNING SPACE. IN ADDITION, THE PEDESTRIAN PUSH BUTTON MUST ALSO BE 5'-0" MINIMUM DISTANCE FROM THE CURB RAMP AND 2'-0" MINIMUM DISTANCE BETWEEN A CATCH BASIN AND THE PEDESTRIAN PUSH BUTTON.
- SIDE FLARES**
 - ALL SLOPES ARE MEASURED WITH RESPECT TO A LEVEL PLANE. THEREFORE, THE LENGTH OF RAMP IS NOT SOLELY DEPENDANT ON THE HEIGHT OF CURB. (FOR EXAMPLE, A 6" CURB DOES NOT NECESSARILY MEAN A RAMP LENGTH OF 6'-0" FOR A 12:1 SLOPE.
 - SIDE FLARES 10.00% MAXIMUM SLOPE WHERE THE PEDESTRIAN PATH CROSSES THE CURB RAMP.
 - SIDE FLARES MUST BE PARALLEL TO THE CURB LINE.
 - GRADE GRASS AREAS OR OTHER NON-WALK AREAS AT 3:1 (1:3) MAXIMUM. DO NOT INSTALL CHEEK WALLS THAT INTERSECT THE PEDESTRIAN ACCESS ROUTE.
 - SIDE FLARE WIDTH IS TYPICALLY 24" AND A MINIMUM OF 12".
- SIDEWALKS**
 - NOTES THE AREA CONSIDERED TO BE THE "PEDESTRIAN ACCESSIBLE ROUTE"
 - THE MAXIMUM SIDEWALK CROSS SLOPE IS 2.00% (MEASURED PERPENDICULAR TO THE DIRECTION OF TRAVEL). THE MAXIMUM GRADE IS 5.00%. FOR SIDEWALKS ALONG STREETS; HOWEVER, THE LONGITUDINAL GRADE OF THE SIDEWALK SHOULD BE CONSISTENT WITH THE GRADE OF THE ADJACENT ROADWAY. IF THE 5.00% GRADE IS NOT FEASIBLE DUE TO TOPOGRAPHY AND OTHER PHYSICAL CONSTRAINTS, THE LOWEST PRACTICAL GRADE GREATER THAN 5.00% SHOULD BE USED.
 - SIDEWALK WIDTH MAY BE REDUCED TO 4'-0", WHEN PASSING AREAS 5'-0" X 5'-0" ARE PROVIDED EVERY 200'.
- TRAVEL LANES**
 - THE TRAVEL LANE IS DEFINED BY THE OUTSIDE EDGE OF THE WHITE PAVEMENT MARKING LINE. IF A WHITE PAVEMENT MARKING LINE DOES NOT EXIST, THE TRAVEL LANE IS DEFINED BY THE CONTRACT DOCUMENTS.
- CONSTRUCTION MUST MEET THE STANDARDS CONTAINED HEREIN UNLESS OTHERWISE NOTED OR DIRECTED.**
- ALL HANDICAP RAMPS CONSTRUCTED IN THIS CONTRACT SHALL MEET ACCESSIBILITY REQUIREMENTS OF THE AMERICANS WITH DISABILITIES ACT AND THE PUBLIC RIGHTS-OF-WAY ACCESSIBILITY GUIDELINES.**
- GRADE BREAKS**
 - GRADE BREAKS AT THE TOP AND BOTTOM OF THE CURB RAMP SHALL BE PERPENDICULAR TO THE DIRECTION OF THE RAMP RUN.
 - GRADE BREAKS ARE NOT PERMITTED ON THE SURFACE OF RAMP RUNS OR TURNING SPACES.
 - SURFACE SLOPES THAT MEET AT THE GRADE BREAKS SHALL BE FLUSH.
- ALL VERTICAL SURFACE DISCONTINUITIES SHALL NOT EXCEED 1/4" IN HEIGHT. ANY VERTICAL SURFACE DISCONTINUITY BETWEEN 1/4" AND 1/2" SHALL BE BEVELED AT A SLOPE NO GREATER THAN 50% ACROSS THE ENTIRE DISCONTINUITY.**
- HORIZONTAL OPENINGS IN GRATES AND JOINTS SHALL NOT EXCEED 1/2" IN DIAMETER AND THE GRATES SHALL BE PLACED SO THE LONG DIMENSION IS PERPENDICULAR TO THE DIRECTION OF TRAVEL.**
- THE CROSS SLOPE FOR CURB RAMPS, BLENDED TRANSITIONS, AND TURNING SPACES SHALL BE 2% MAXIMUM. AT PEDESTRIAN STREET CROSSINGS WITHOUT YIELD OR STOP CONTROL, THE CROSS SLOPE SHALL BE PERMITTED TO MATCH THE STREET GRADE. PEDESTRIAN STREET CROSSINGS WITHOUT YIELD OR STOP CONTROL ARE CROSSINGS WHERE THERE IS NO YIELD OR STOP SIGN, OR WHERE THERE IS A TRAFFIC SIGNAL THAT IS DESIGNED FOR THE GREEN PHASE.**

DETECTABLE WARNING SURFACE (DWS) INSTALLATION INSTRUCTIONS

- LAY OUT AND PROPERLY FIT EACH UNIT PRIOR TO SETTING IN WET CONCRETE.
- CUT UNITS AS NECESSARY ALONG PERIMETER OF DETECTABLE WARNING SURFACE.
- PLACE UNITS ACROSS THE ENTIRE WIDTH OF THE CURB RAMP SURFACE AND/OR WHERE THE CURB IS FLUSH.
- PRESS UNITS INTO FULL CONTACT WITH THE FRESH CONCRETE.
- ADJUST HEIGHT OF EACH UNIT EDGE TO BE LEVEL WITH ADJACENT RAMP SURFACES.
- ONLY TRUNCATED DOMES SHOULD BE ABOVE THE ADJACENT FINISHED CONCRETE.
- FILL ANY SAW CUT GAPS WITH APPROVED JOINT SEALANT MATERIAL.

DWS NOTES:

- THE DETAILS PROVIDED ARE NOT DRAWN TO SCALE. THE QUANTITY OF DOMES DEPICTED ON THE DETECTABLE WARNING UNIT (THE DOMES AND THE ENTIRE 24" LEVEL SURFACE) IS FOR ILLUSTRATION ONLY.

DETECTABLE WARNING UNIT DIMENSIONS:

- THE SIZE OF THE DETECTABLE WARNING FIELD SHALL BE 24" IN THE DIRECTION OF TRAVEL AND SHALL EXTEND THE FULL WIDTH OF THE CURB RAMP OR FLUSH SURFACE, EXCLUSIVE OF SIDE FLARES.

DOMES ALIGNMENT:

- THE ROWS OF DOMES SHALL BE ALIGNED TO BE PERPENDICULAR OR RADIAL TO THE GRADE BREAK BETWEEN THE RAMP TURNING SPACE OR CURB RAMP AND THE STREET.
- WHERE DOMES ARE ARRAYED RADIALLY THEY MAY DIFFER IN DOME DIAMETER AND CENTER-TO-CENTER SPACING WITHIN THE RANGES SPECIFIED ON THIS SHEET.

COLOR REQUIREMENTS:

- THE DETECTABLE WARNING FIELD SHALL BE THE COLOR "SAFETY RED" UNLESS NOTED OTHERWISE IN THE CONTRACT DOCUMENTS AND MUST MEET THE REQUIREMENTS OF THE STANDARD SPECIFICATIONS.

DETECTABLE WARNINGS LOCATIONS:

- DETECTABLE WARNINGS SHALL BE LOCATED SO THAT THE EDGE OR CORNER OF THE WARNING FIELD NEAREST TO THE ROADWAY IS 5' TO 9' FROM THE FRONT OF THE CURB OR THE ROADWAY EDGE (12' WHERE TRAVERSABLE CURB IS USED).
- THE EDGE OF THE DETECTABLE WARNING FIELD NEAREST TO A RAILROAD CROSSING SHALL BE 6'-0" MINIMUM AND 15'-0" MAXIMUM FROM THE CENTERLINE OF THE NEAREST RAIL.

EQUIVALENT SLOPES

PERCENT SLOPE	EQUIVALENT SLOPE
10.00%	10:1
8.33%	12:1
7.14%	14:1
5.00%	20:1
2.00%	50:1
1.00%	100:1

TABLE OF CONTENTS		
SHEET	DETAIL	DESCRIPTION
1	GENERAL NOTES	GENERAL GUIDELINES
2	TYPE 1 CURB RAMPS	SINGLE EXIT INTO ROADWAY; ONE DIRECTION EXIT RAMP
3	TYPE 1 CURB RAMPS	SINGLE EXIT INTO ROADWAY; ONE DIRECTION EXIT RAMP
4	TYPE 1 CURB RAMPS	SINGLE EXIT INTO ROADWAY; ONE DIRECTION EXIT RAMP
5	TYPE 2 CURB RAMPS	DOUBLE EXIT INTO ROADWAY; SEPARATE EXIT RAMPS
6	TYPE 2 CURB RAMPS	DOUBLE EXIT INTO ROADWAY; SEPARATE EXIT RAMPS
7	TYPE 2 CURB RAMPS	DOUBLE EXIT INTO ROADWAY; SEPARATE EXIT RAMPS
8	TYPE 3 CURB RAMPS	DOUBLE EXIT INTO ROADWAY; SINGLE EXIT RAMP
9	TYPE 3 CURB RAMPS	DOUBLE EXIT INTO ROADWAY; SINGLE EXIT RAMP
10	TYPE 3 CURB RAMPS	DOUBLE EXIT INTO ROADWAY; SINGLE EXIT RAMP
11	TYPE 4 CURB RAMPS	MEDIAN & ISLAND CURB RAMPS
12	TYPE 4 CURB RAMPS	MEDIAN & ISLAND CURB RAMPS
13	TYPE 4 CURB RAMPS	MEDIAN & ISLAND CURB RAMPS
14	TYPE 5 CURB RAMPS	DRIVEWAY DETAILS
15	TYPICAL SECTIONS	TYPICAL DETAILS
16	TYPICAL SECTIONS	TYPICAL DETAILS
17	RAMP & SIDEWALK SPECIFICATIONS	TYPICAL DETAILS
18	DWS SPECIFICATIONS	TYPICAL DETAILS
19	DWS SPECIFICATIONS	TYPICAL DETAILS
20	DWS SPECIFICATIONS	TYPICAL DETAILS
21	PUSH BUTTON SPECIFICATIONS	TYPICAL DETAILS
22	TYPICAL INTERSECTION DETAIL	TYPICAL DETAILS
23	TYPICAL INTERSECTION DETAIL	TYPICAL DETAILS

NOTE TO ENGINEER:

ADA01 IS INCLUDED IN ALL CONTRACTS W/CURB RAMP CONSTRUCTION. USE THE "ADA" DOUBLE REFERENCE CODE IN THE CONTRACT FOR THE DETAILS (SEPERATE FROM CONSTRUCTION DETAILS).

CURB RAMPS AND SIDEWALKS

GENERAL NOTES

DATE	REVISIONS	BY	CHK.
DETAILS FOR OCEAN COUNTY ADA DETAILS & SPECIFICATIONS			
ADA CURB RAMP DETAILS			
DATE	BY	DESIGNED	CHECKED
SCALE	N.T.S.	DRAWN	APPROVED
			F.S.S.
FILE NO. 194			SHEET 1 OF 23

JOHN N. ERNST
COUNTY ENGINEER

P.E. No. 33347

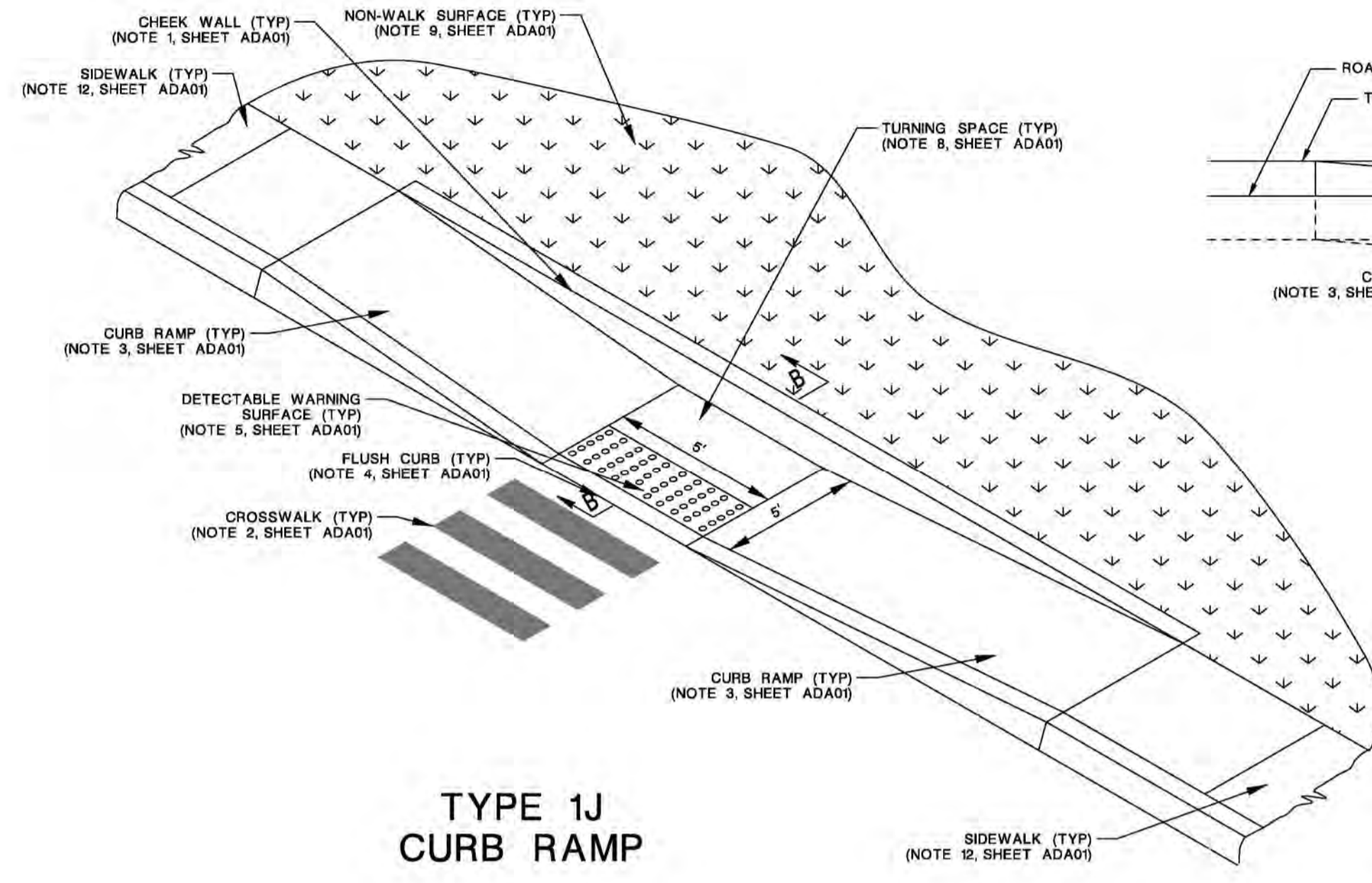

**TYPE 1J
CURB RAMP**

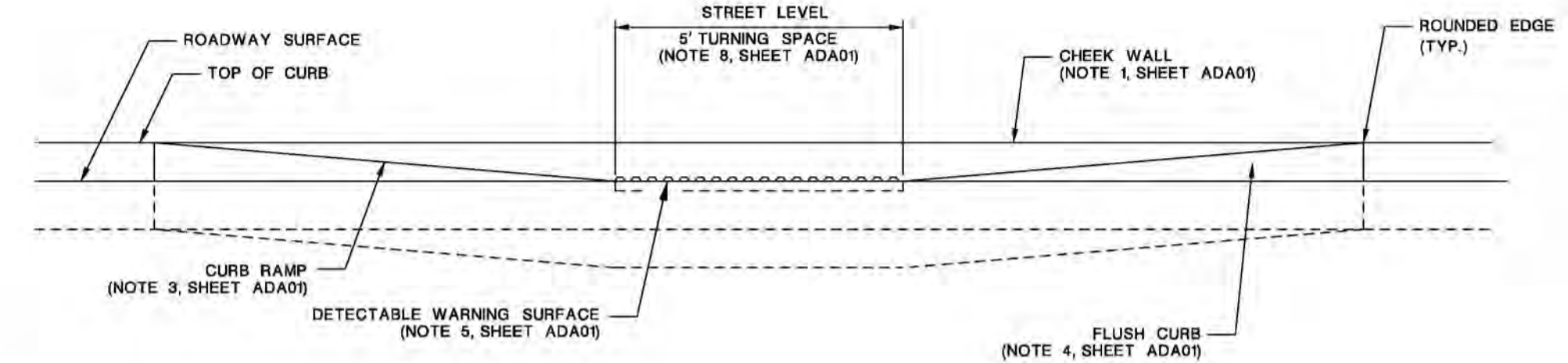

**TYPE 1J
CURB RAMP
ELEVATION**

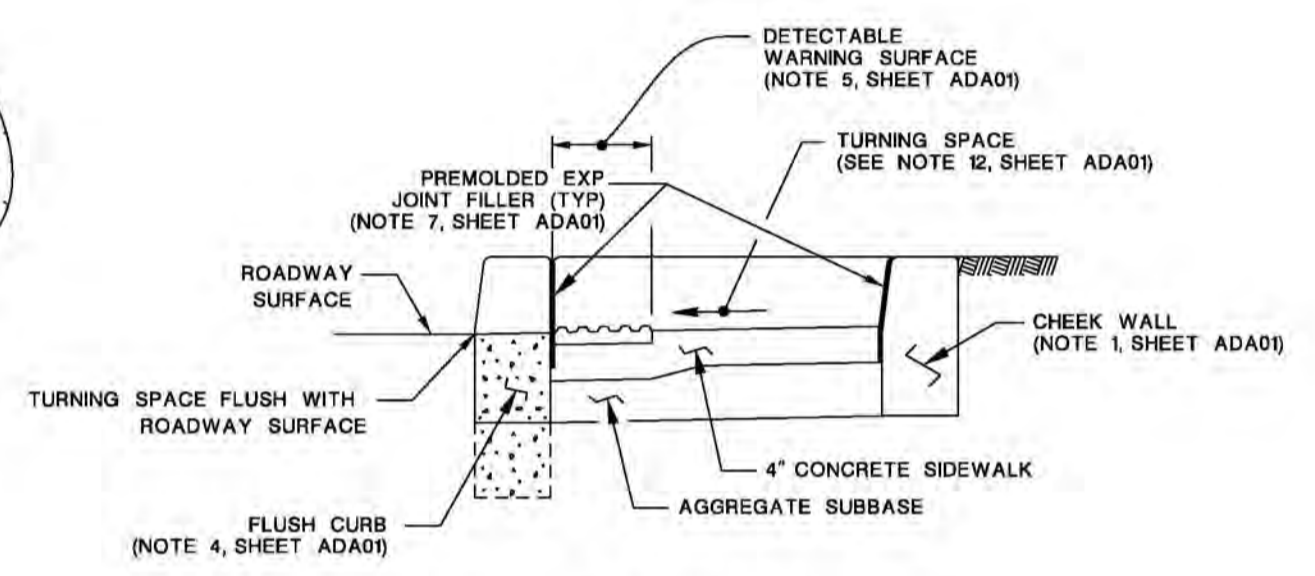

**SECTION B-B
CURB RAMP**

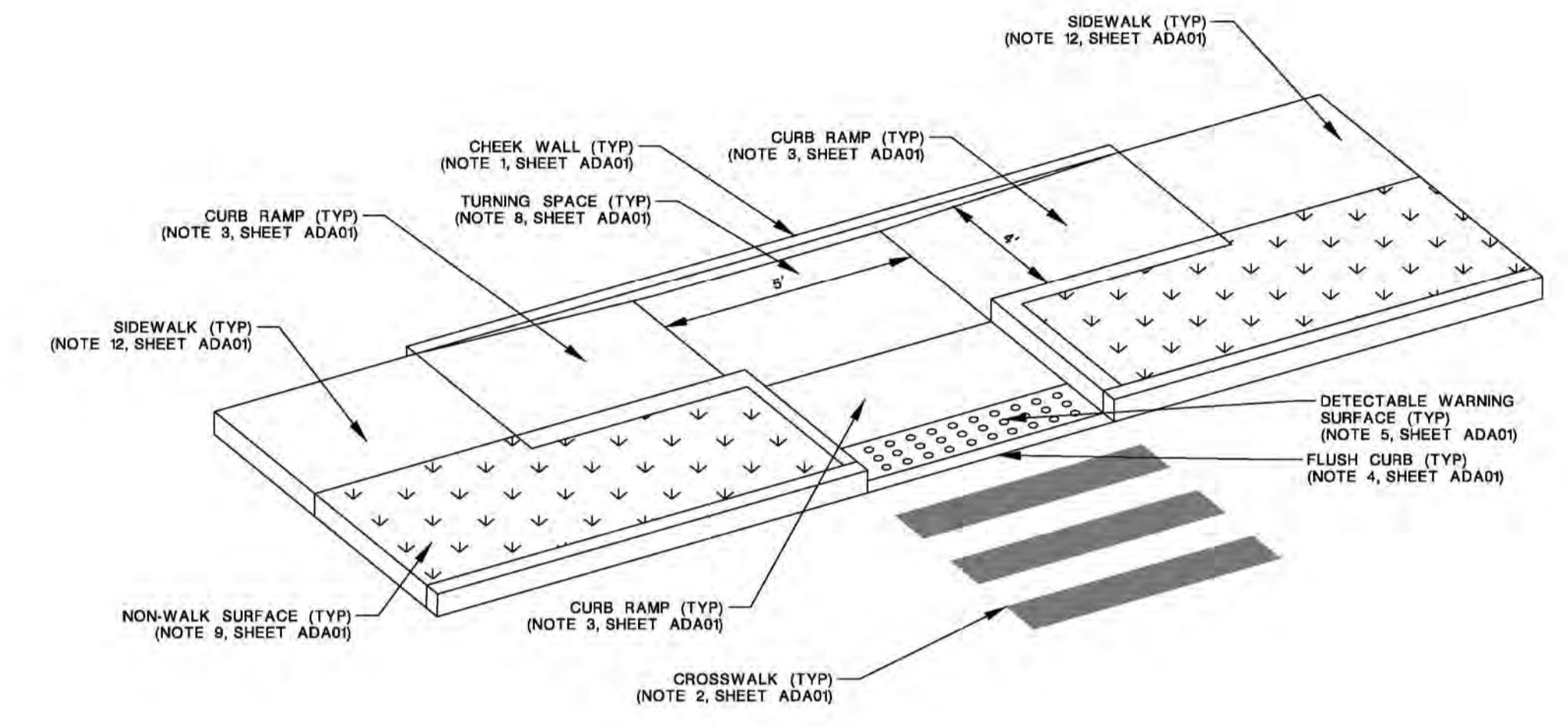

**TYPE 1K
CURB RAMP**

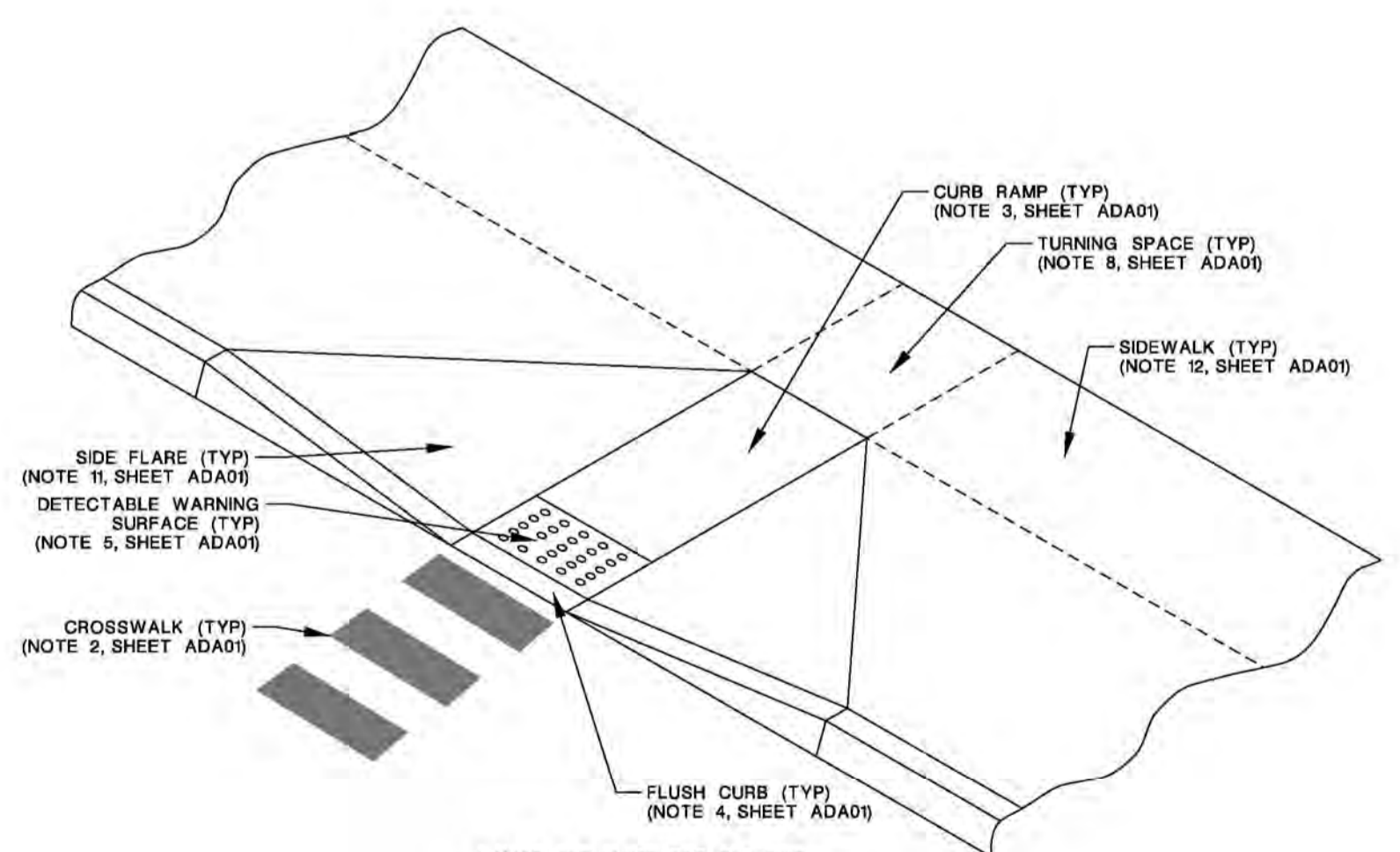

* NOTE: THE SLOPE FOR THE SIDE FLARES FOR THIS CURB RAMP CONFIGURATION MUST BE NO GREATER THAN 8.00% DUE TO THE CONCRETE SIDEWALK EXTENDING FROM THE PEDESTRIAN ACCESSIBLE ROUTE TO THE CURB

**TYPE 1L
CURB RAMP**

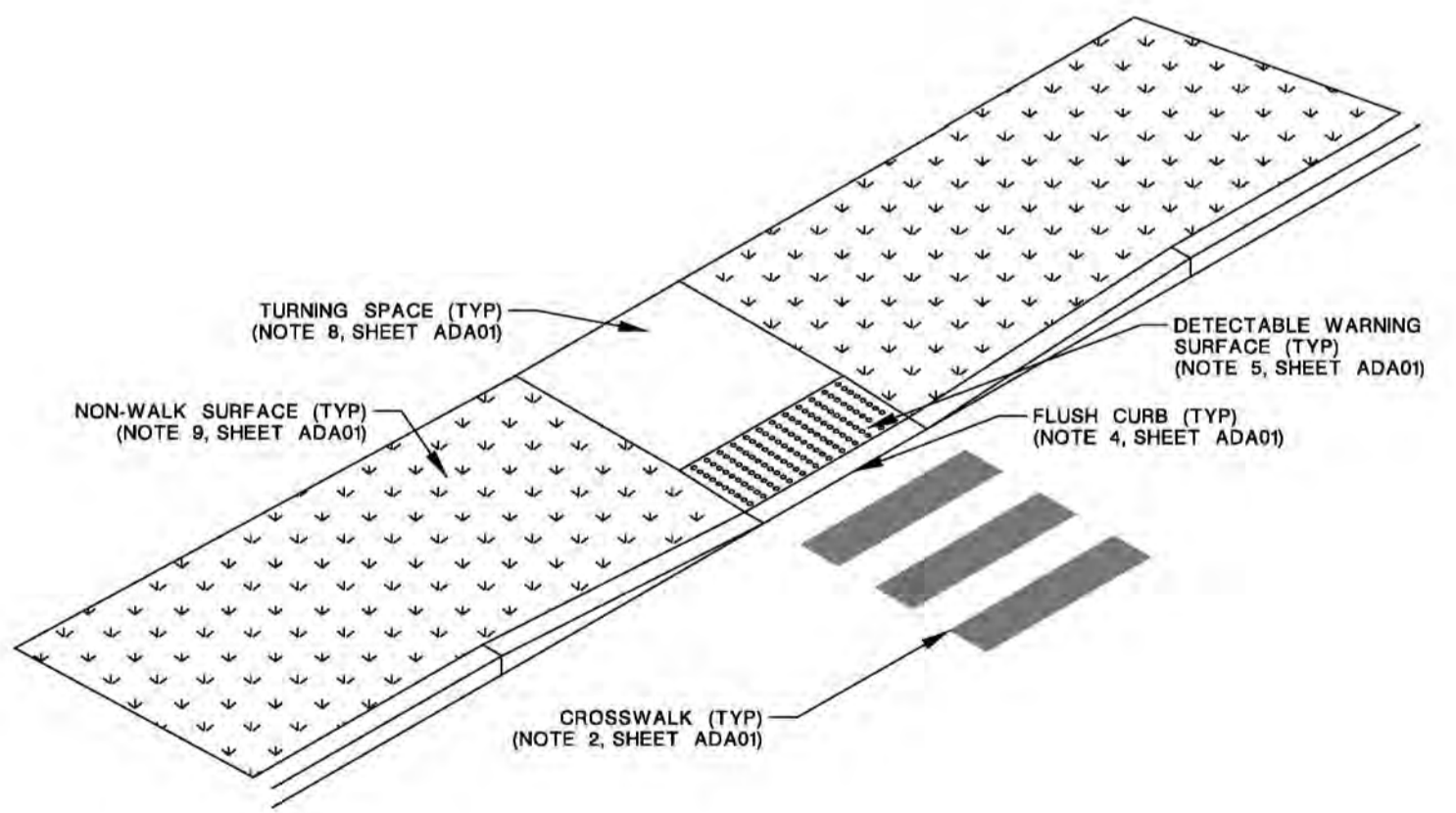

**TYPE 1M
CURB RAMP**

* ONLY USED WITH OCEAN COUNTY ENGINEER'S APPROVAL
** ONLY USED IN AREAS WHERE NO EXISTING SIDEWALK EXISTS, WHERE PROVIDING ACCESS OFF ROADWAY OR TO PEDESTRIAN PUSH BUTTONS

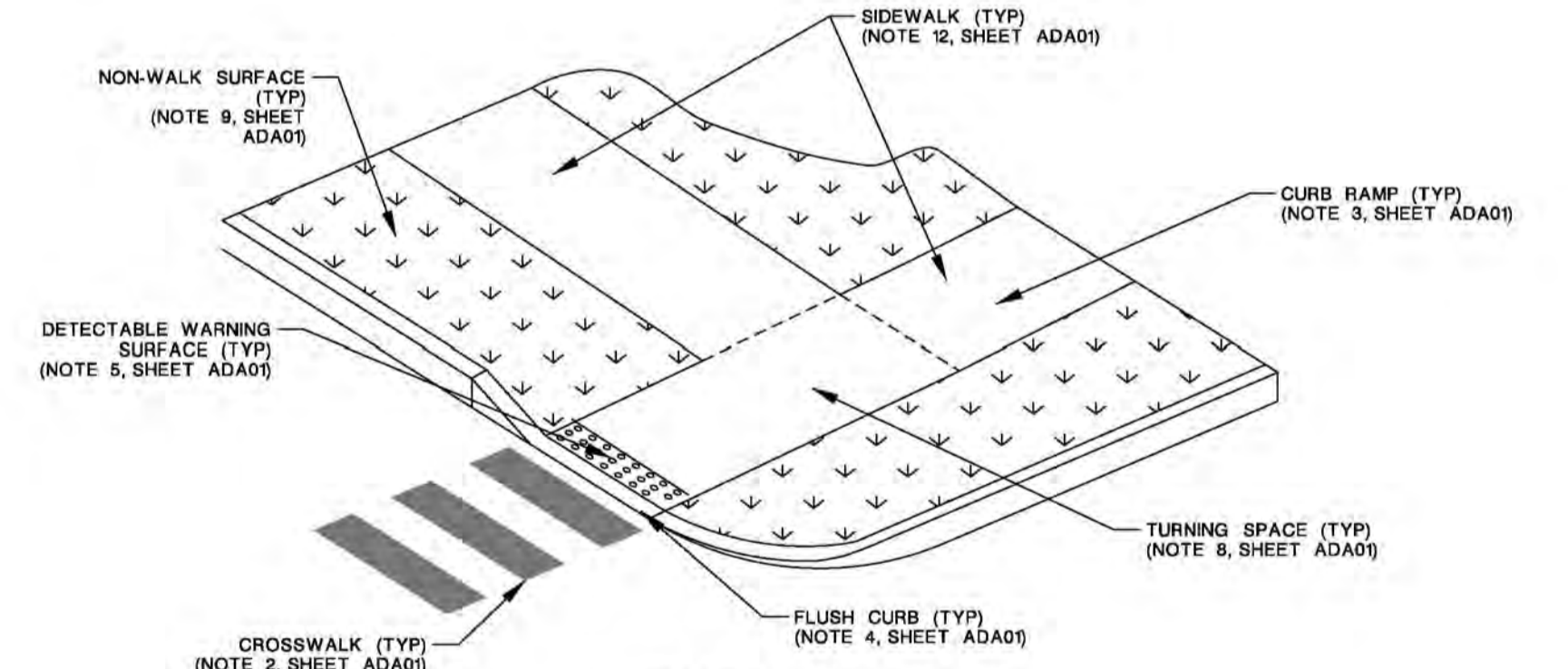

**TYPE 1N
CURB RAMP**

CURB RAMPS AND SIDEWALKS

TYPE 1

DATE	REVISIONS	BY	CHK.
DETAILS FOR			
OCEAN COUNTY			
ADA DETAILS & SPECIFICATIONS			
ADA CURB RAMP DETAILS			
DATE	BY	DESIGNED	CHECKED
SCALE	N.T.S.	DRAWN	APPROVED
 JOHN N. ERNST COUNTY ENGINEER			SHEET 3 OF 28

11/15/2011 10:00 AM C:\Users\johnd\OneDrive\Documents\11-15-2011 10:00 AM\11-15-2011 10:00 AM.dwg

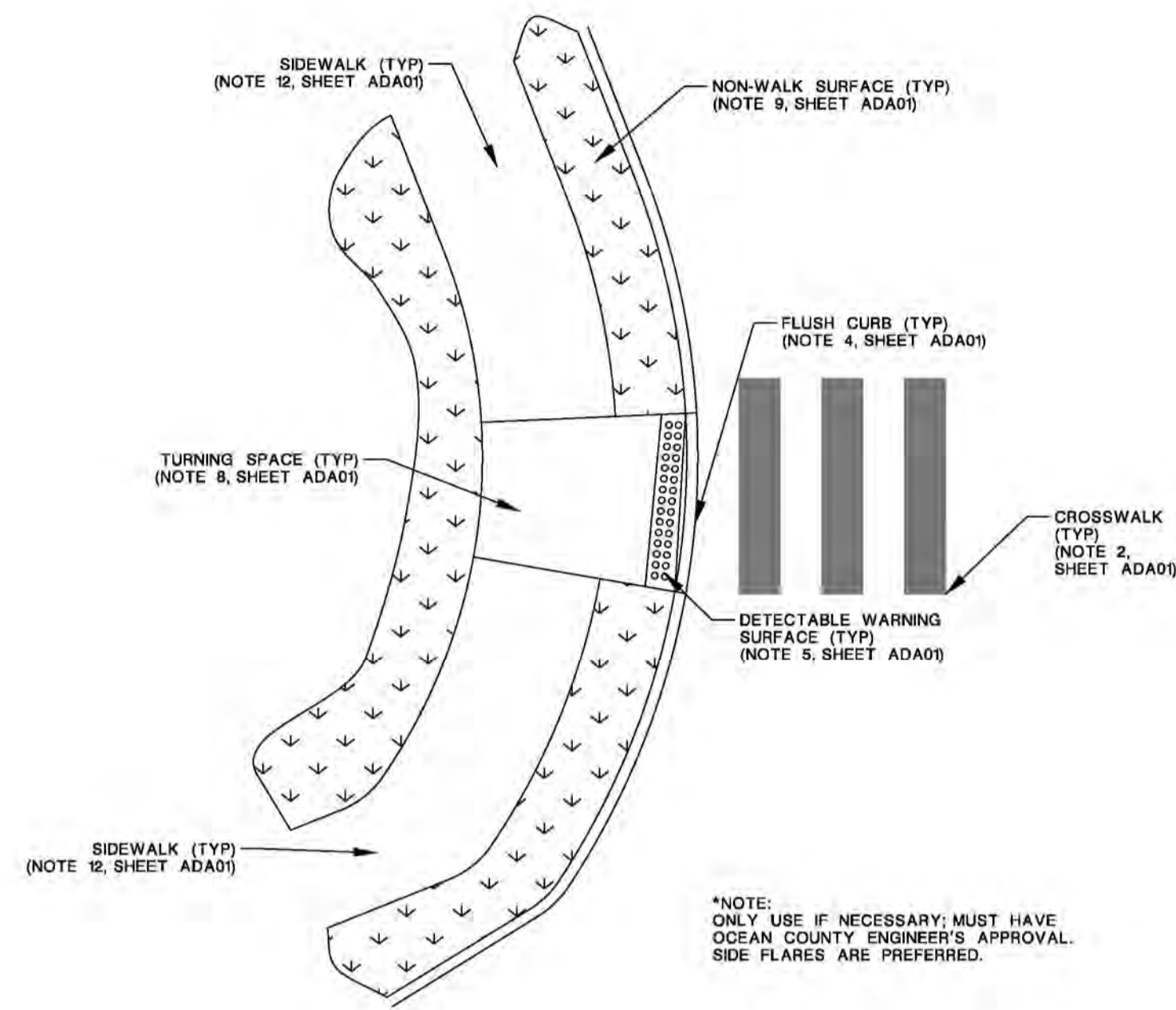

TYPE 1P
CURB RAMP

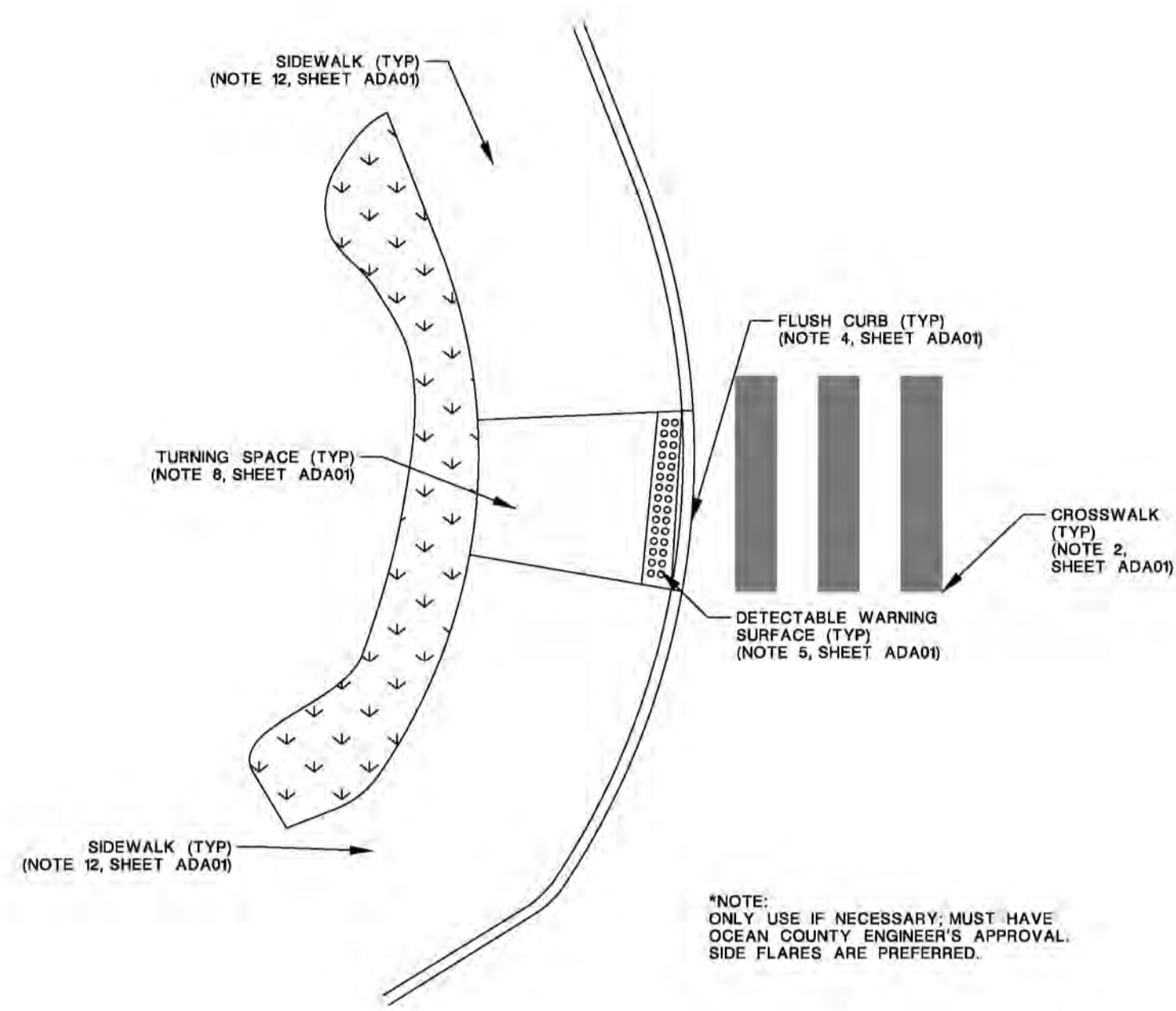

TYPE 1Q
CURB RAMP

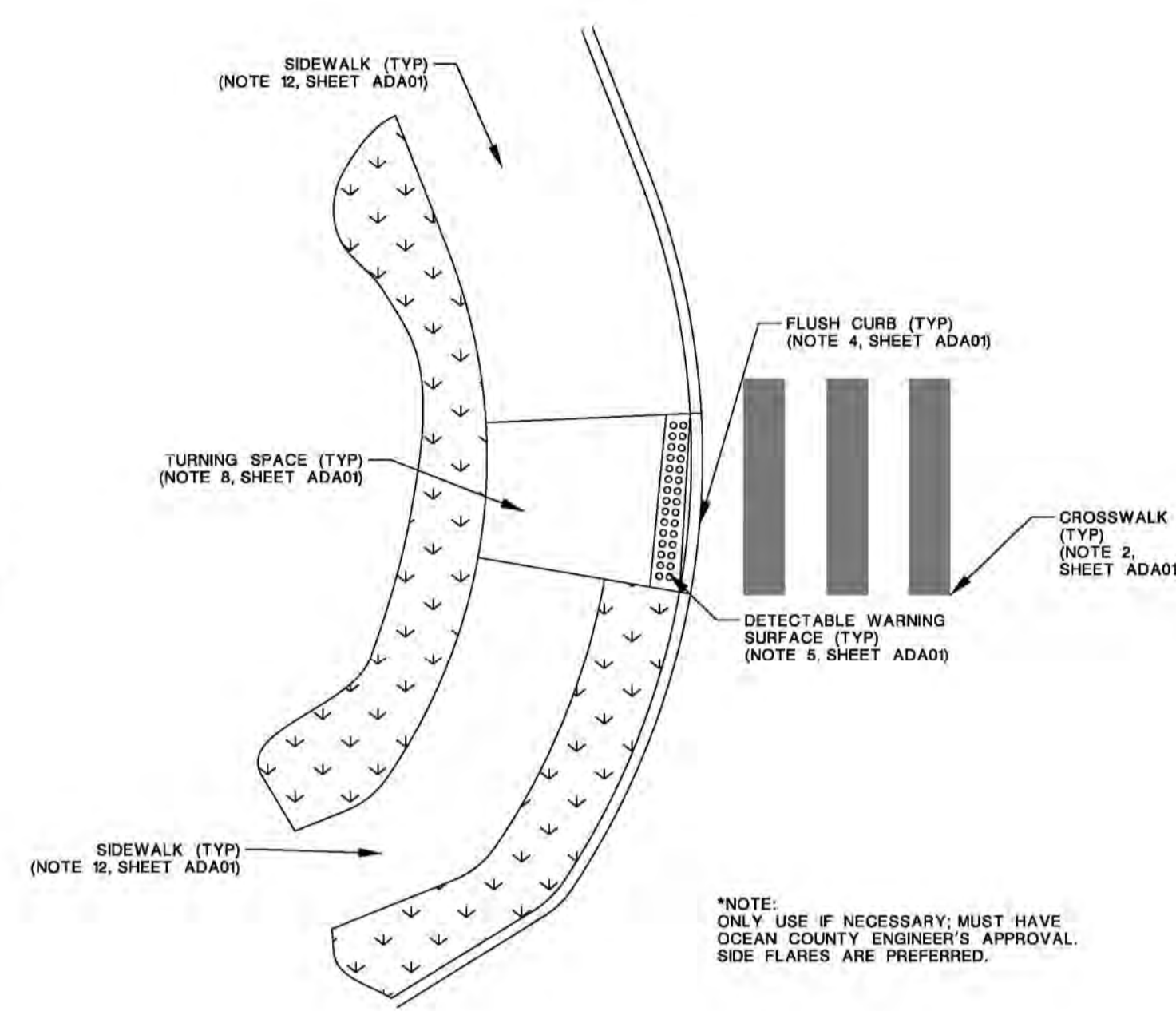

TYPE 1R
CURB RAMP

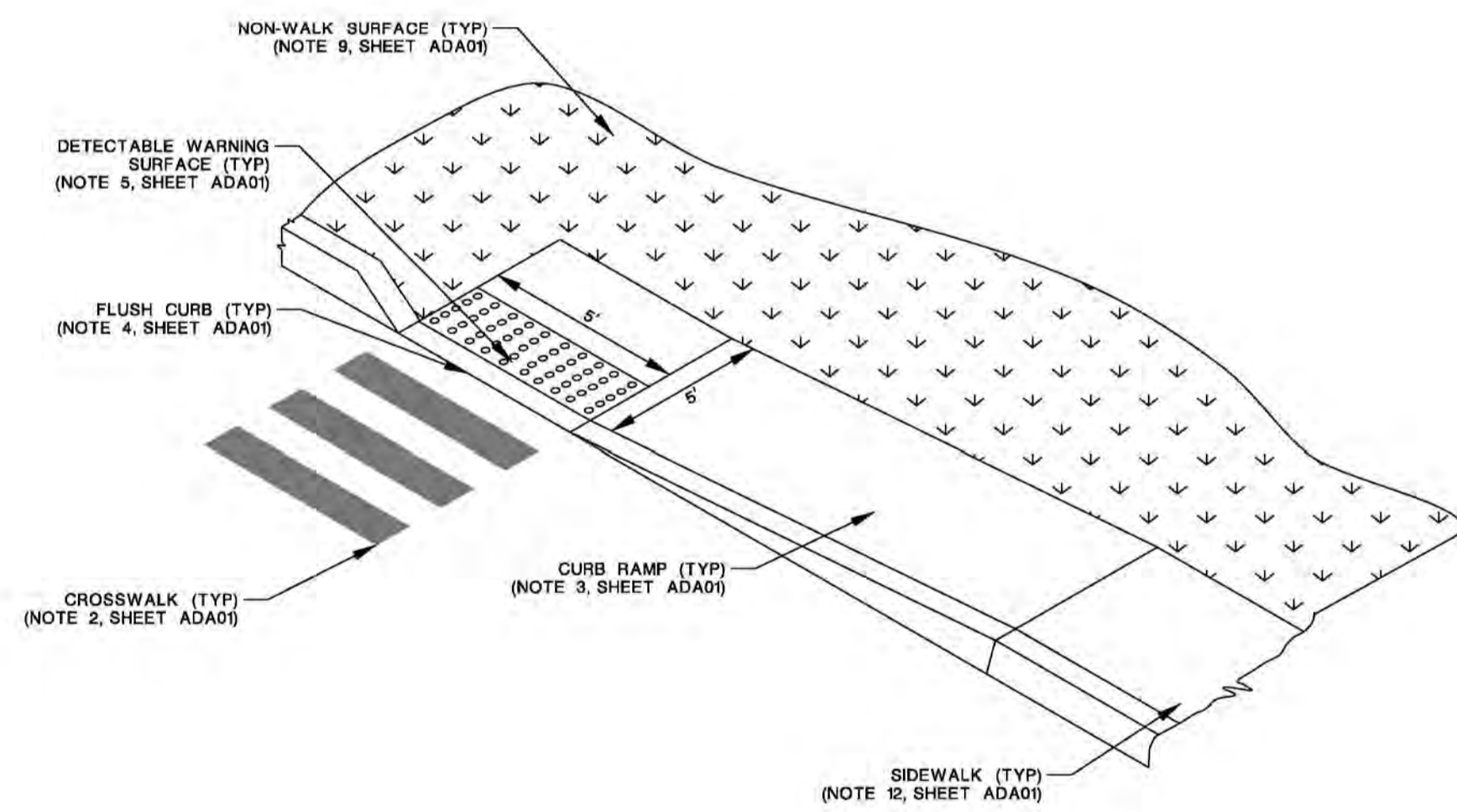

TYPE 1S
CURB RAMP

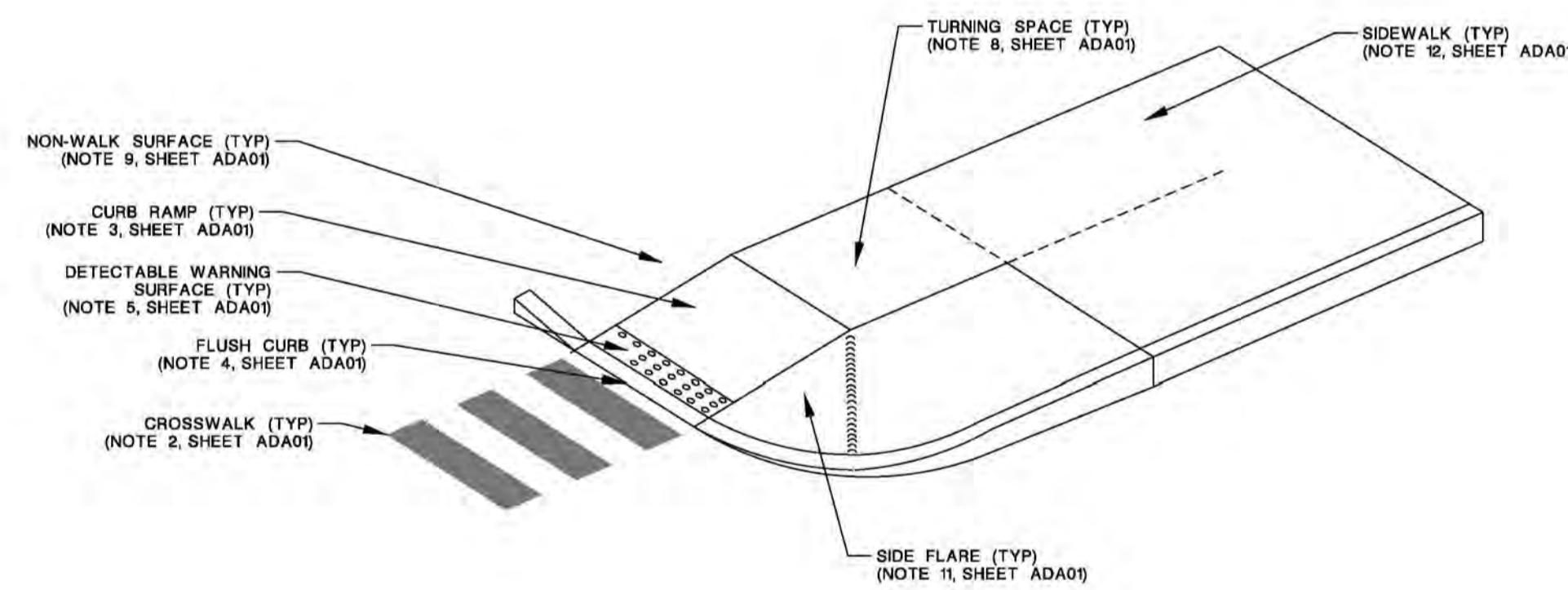

TYPE 1T
CURB RAMP

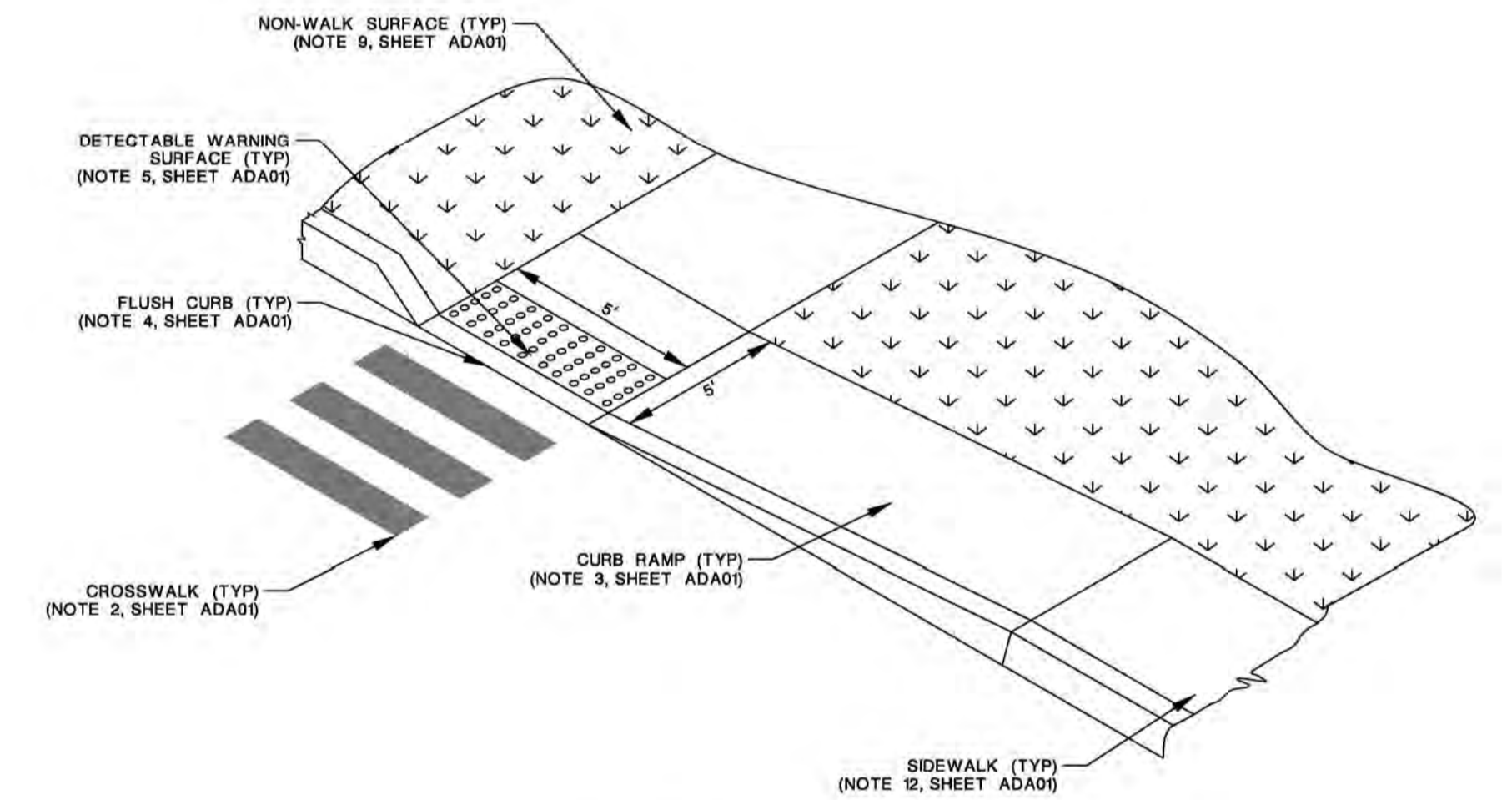

TYPE 1U
CURB RAMP

CURB RAMPS AND SIDEWALKS

TYPE 1

DATE	REVISIONS	BY	CHK.
DETAILS FOR			
OCEAN COUNTY			
ADA DETAILS & SPECIFICATIONS			
ADA CURB RAMP DETAILS			
DATE	DESIGNED	CHKD	CRW
SCALE	N.T.S.	DRAWN	APPROVED
			F.B.B.
FILE NO.			SHEET 4 OF 23



11/15/2011 10:00 AM 11/15/2011 10:00 AM 11/15/2011 10:00 AM

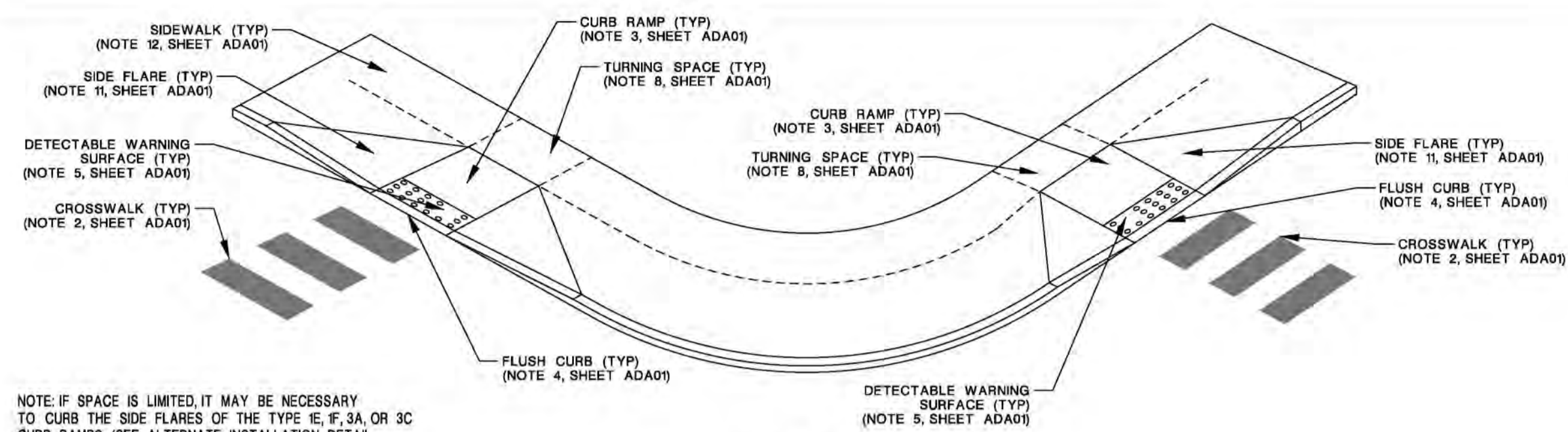

**TYPE 2A
CURB RAMP
(PREFERRED INSTALLATION)**

NOTE: IF SPACE IS LIMITED, IT MAY BE NECESSARY TO CURB THE SIDE FLARES OF THE TYPE E, F, 3A, OR 3C CURB RAMPS (SEE ALTERNATE INSTALLATION DETAIL BELOW AS TYPE 2C). PEDESTRIAN TRAFFIC SHOULD NOT BE DIRECTED TO CROSS THE VERTICAL DROP.

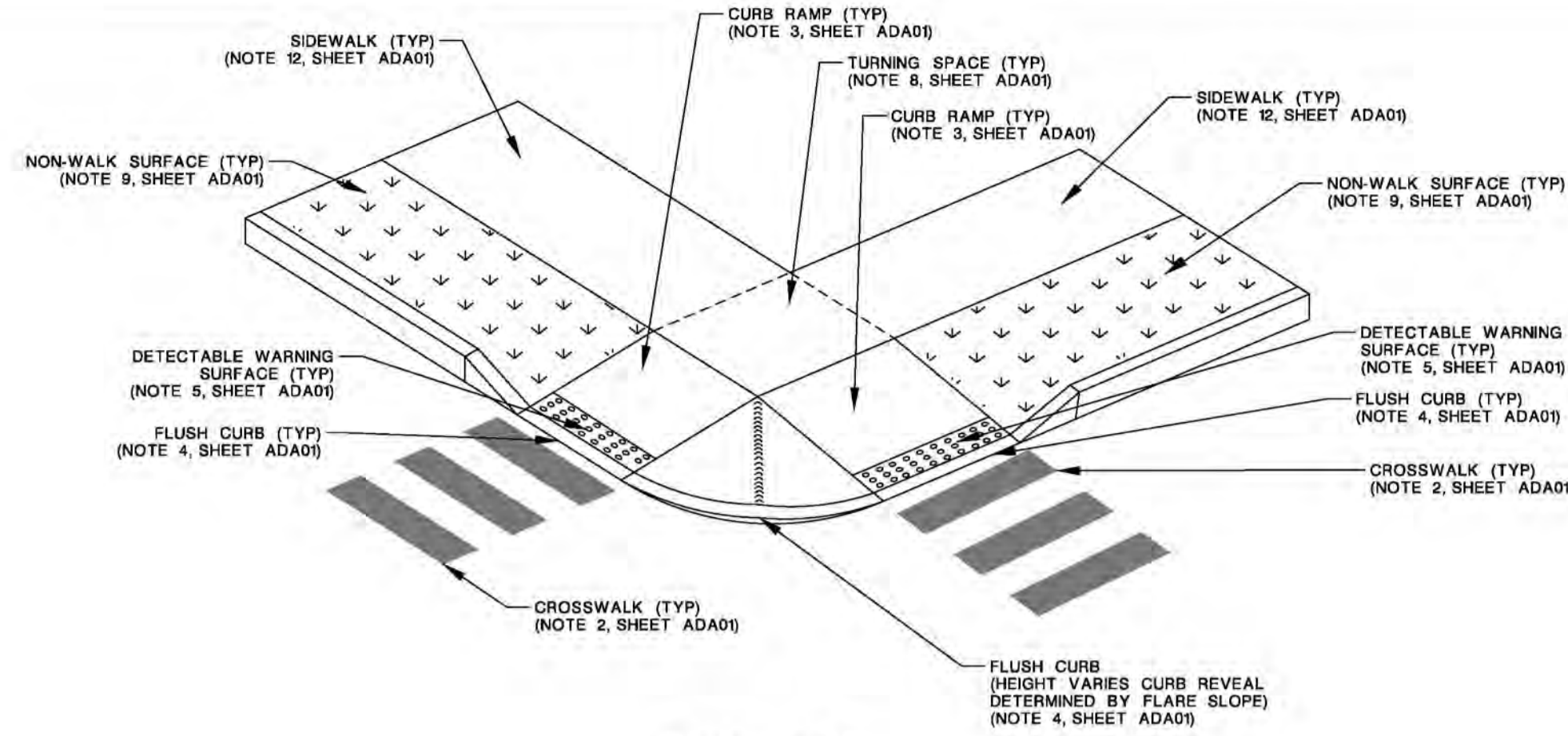

**TYPE 2B
CURB RAMP**

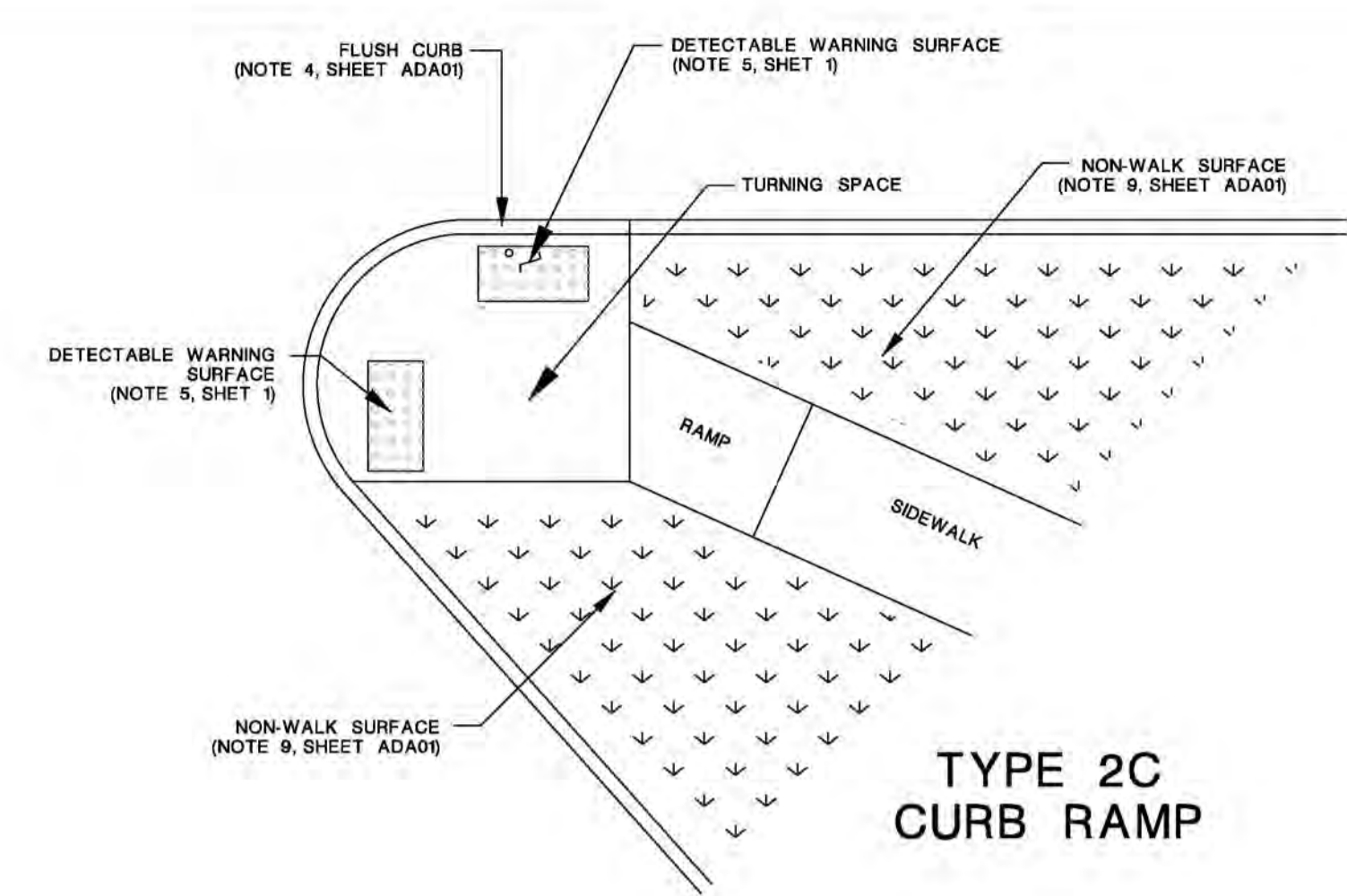

**TYPE 2C
CURB RAMP**

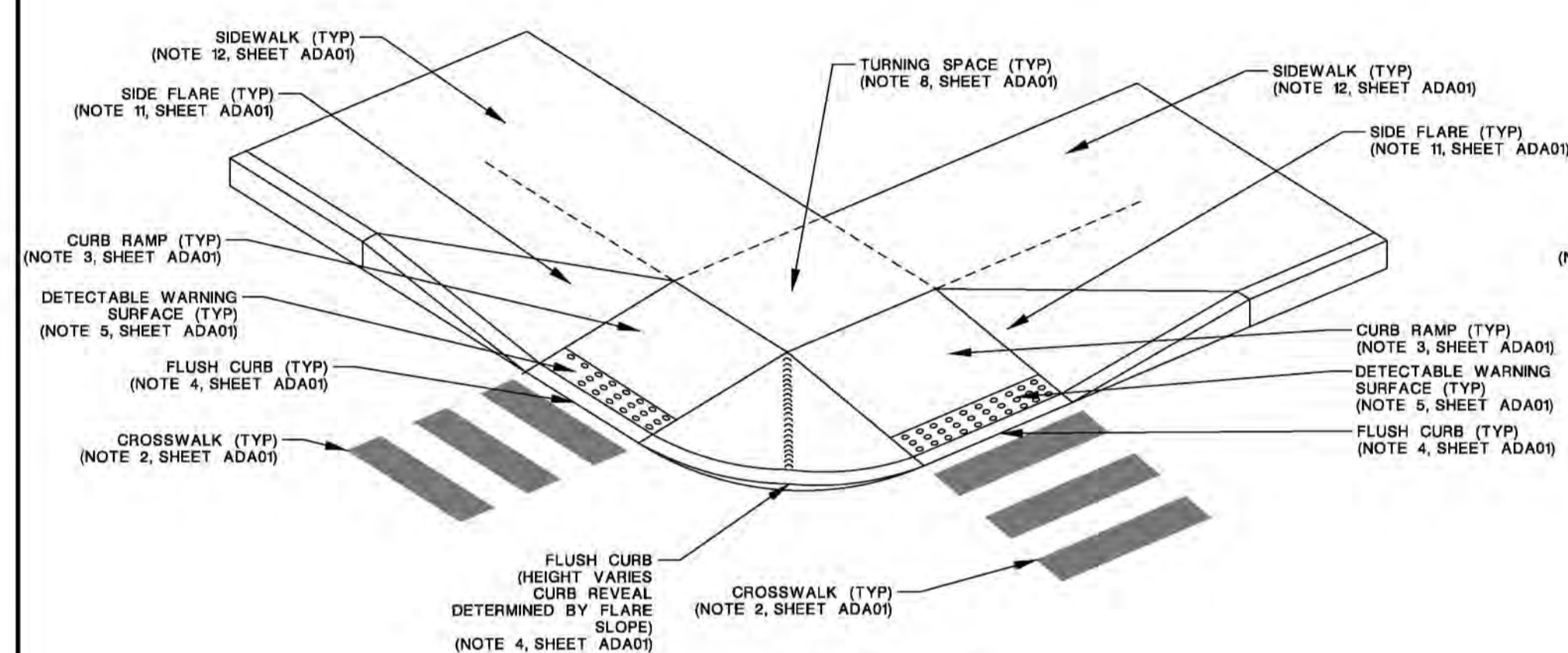

**TYPE 2D
CURB RAMP**

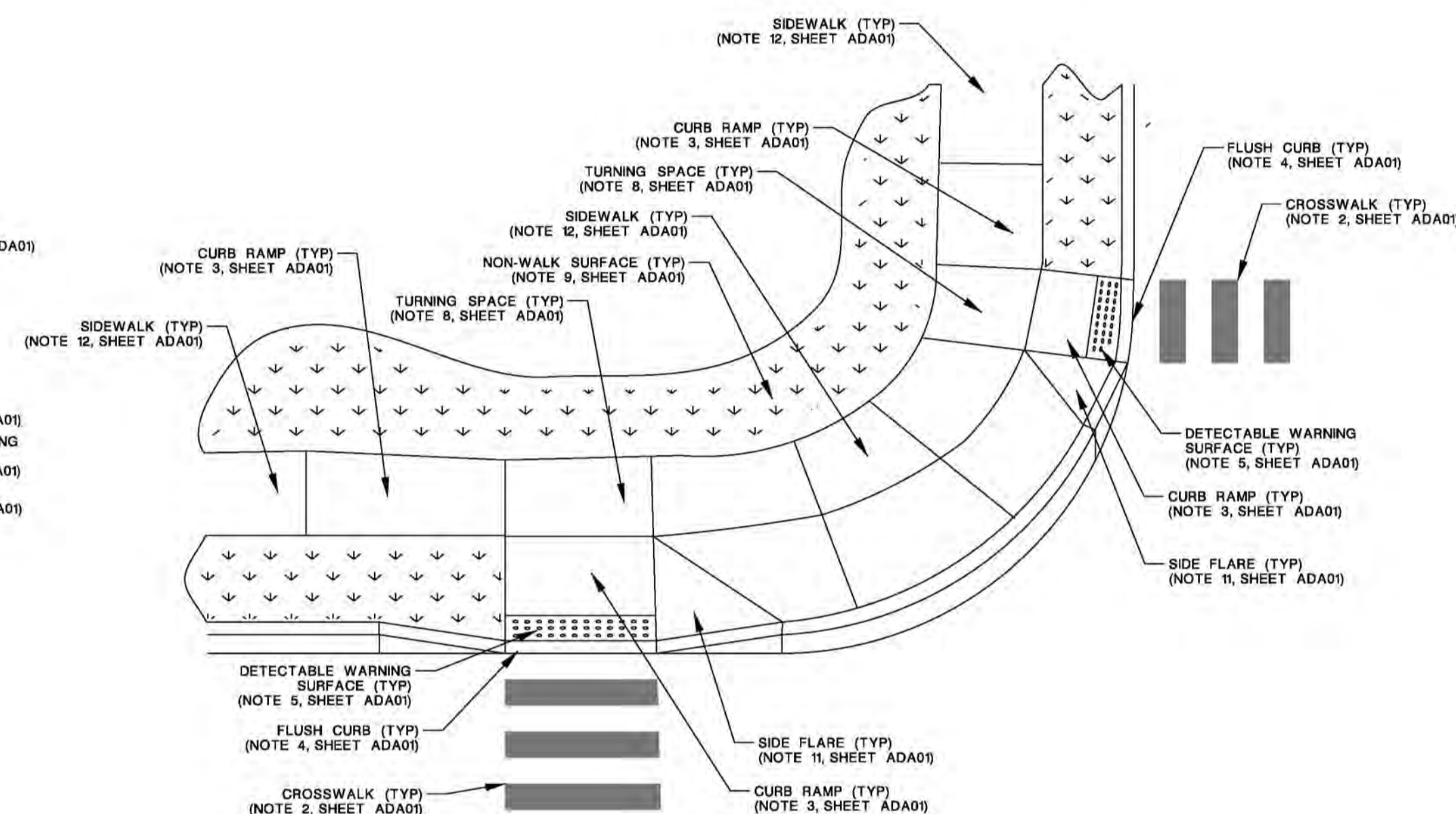

**TYPE 2E
CURB RAMP**

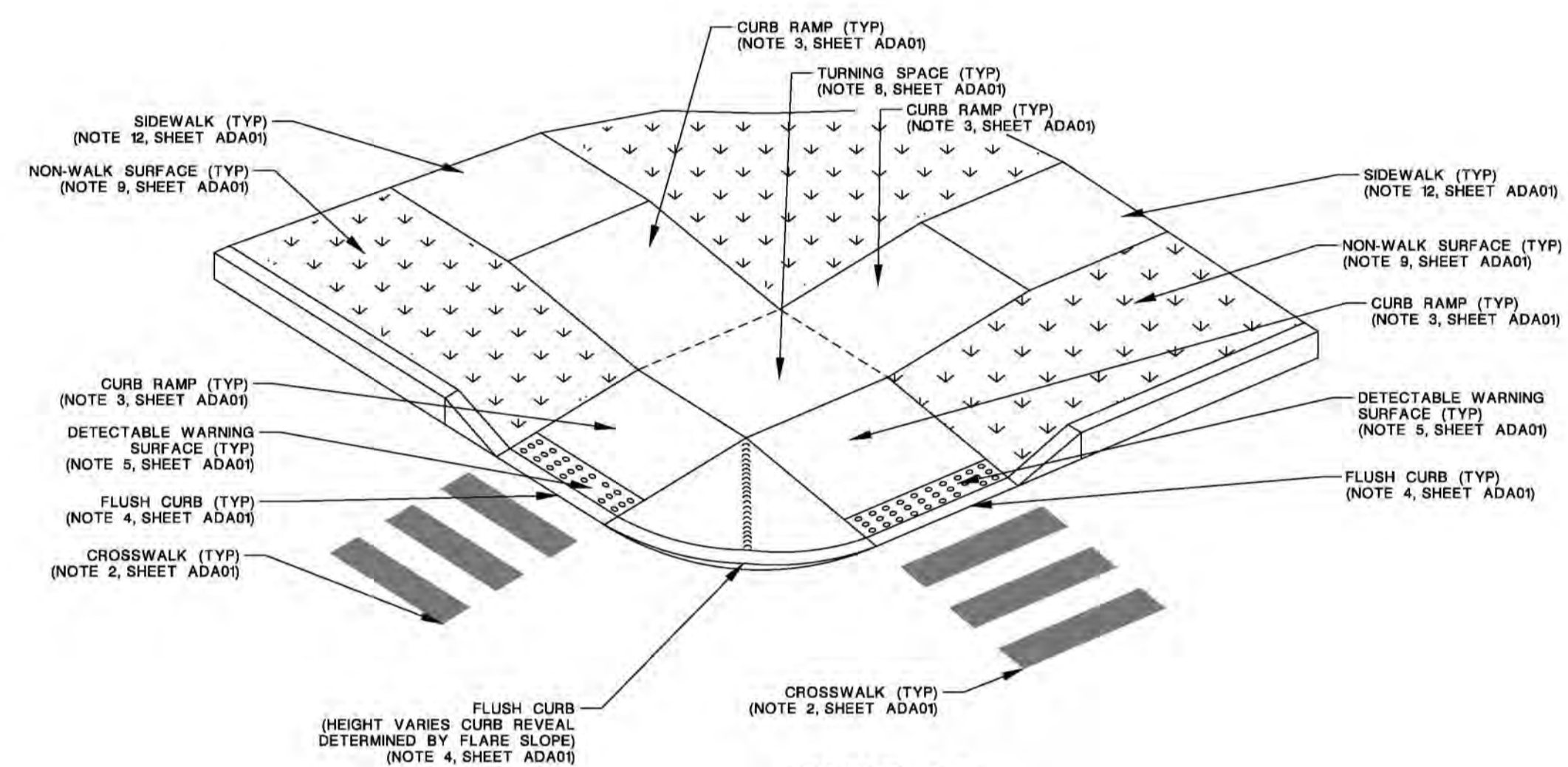

**TYPE 2F
CURB RAMP**

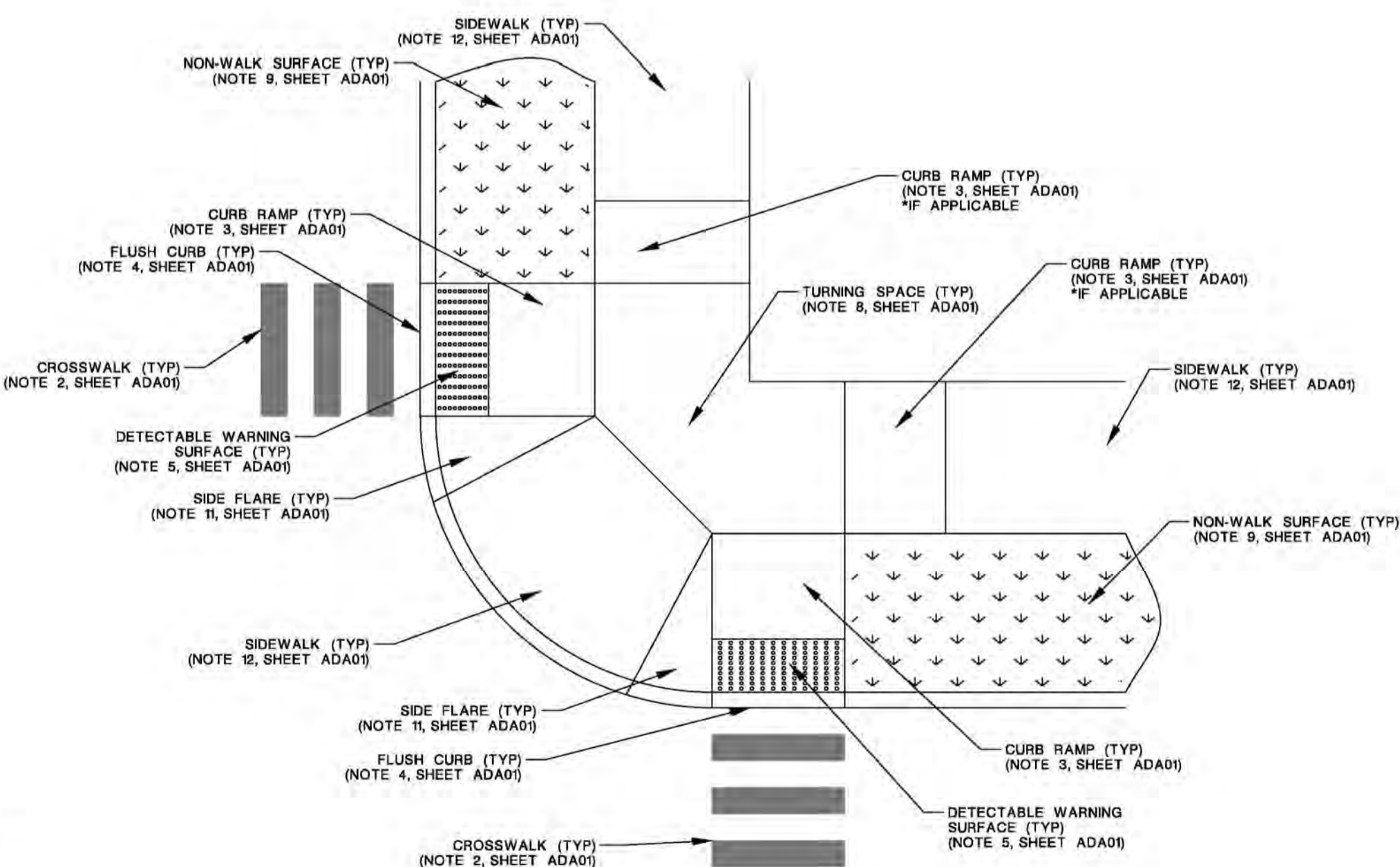

**TYPE 2G
CURB RAMP**

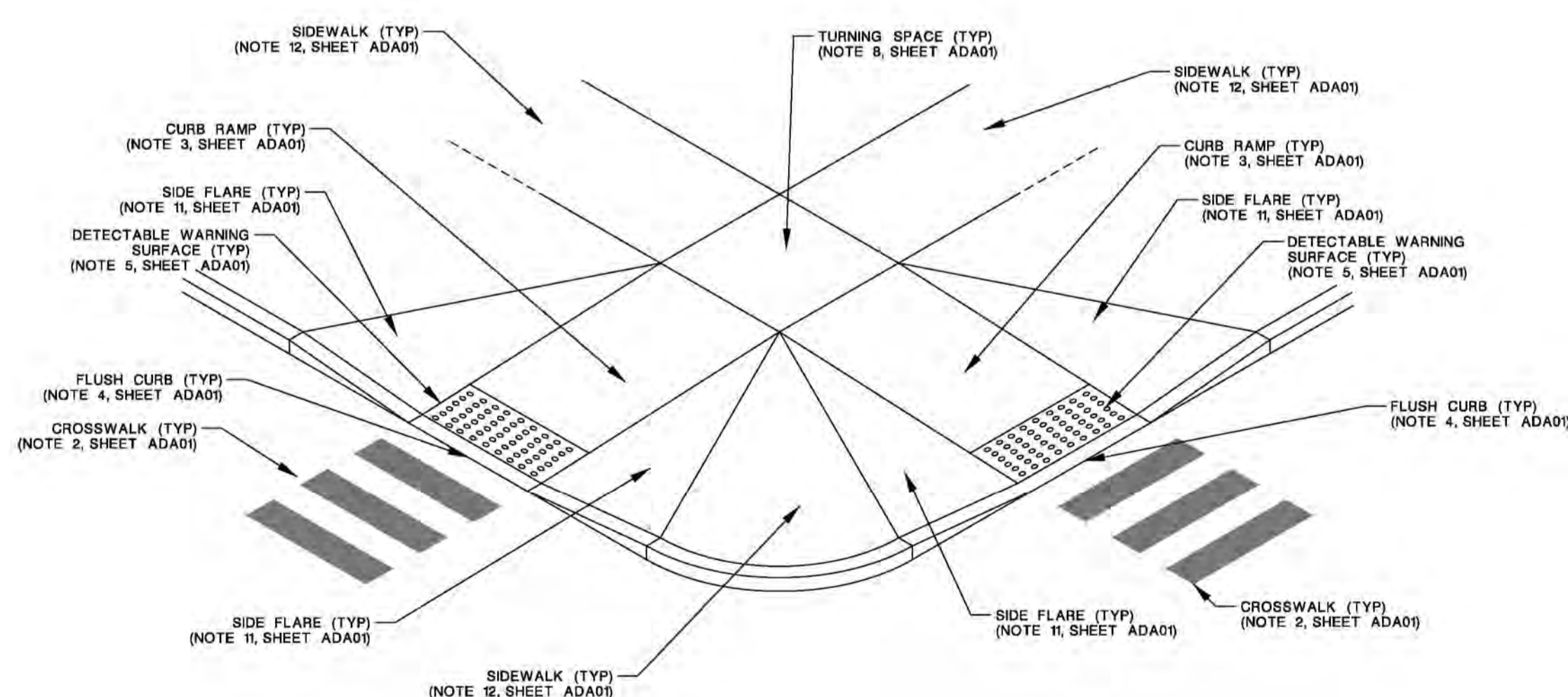

**TYPE 2H
CURB RAMP**

CURB RAMPS AND SIDEWALKS

TYPE 2

DATE	REVISIONS	BY	CHK.
 OCEAN COUNTY ADA DETAILS & SPECIFICATIONS ADA CURB RAMP DETAILS			
DATE	DRAWN	CHECKED	DATE
SCALE	N.T.S.	APPROVED	F.S.B.
JOHN N. ERNST COUNTY ENGINEER			SHEET 5 OF 23

11/15/2011 10:00 AM 11/15/2011 10:00 AM 11/15/2011 10:00 AM

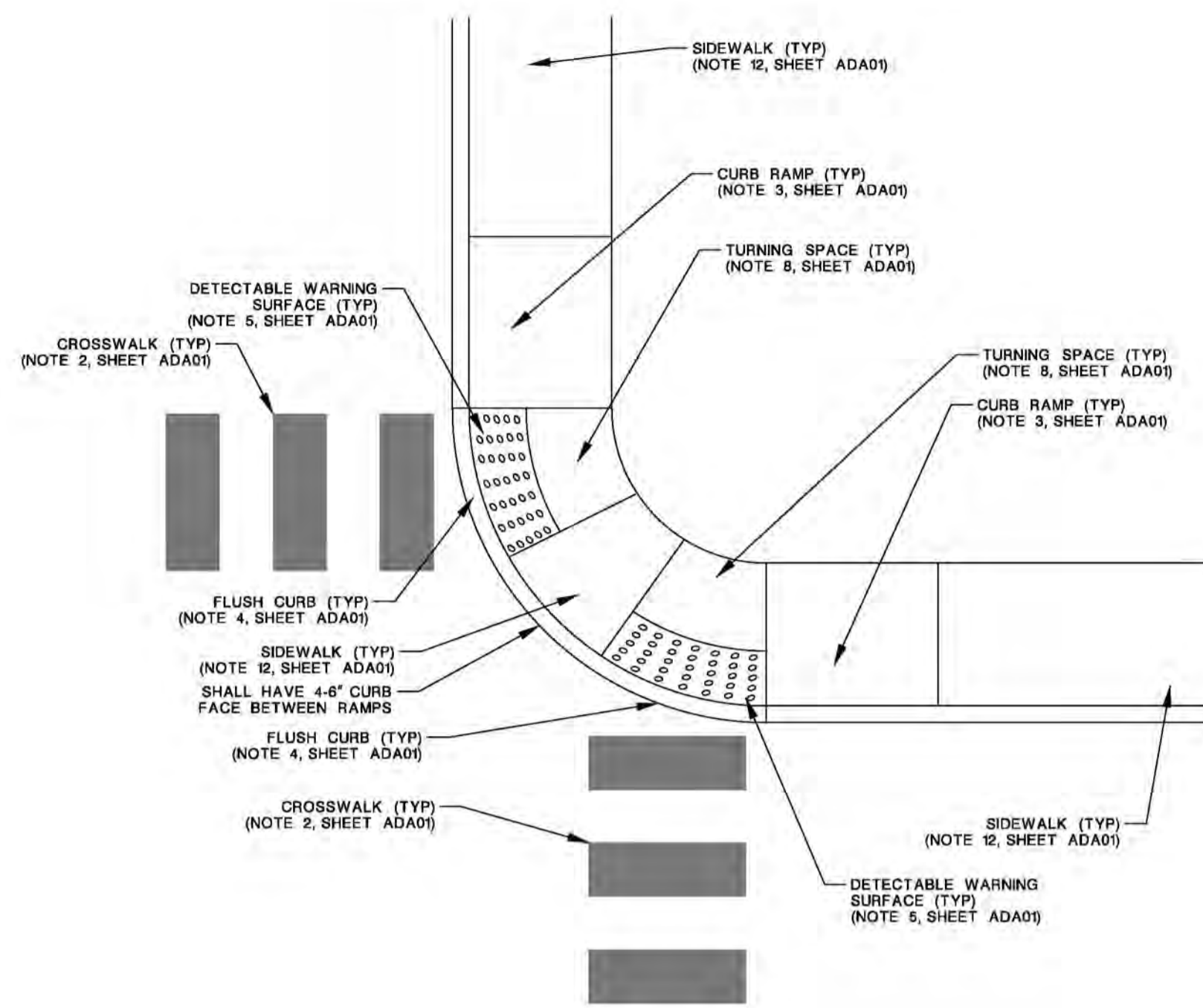

TYPE 2I CURB RAMP

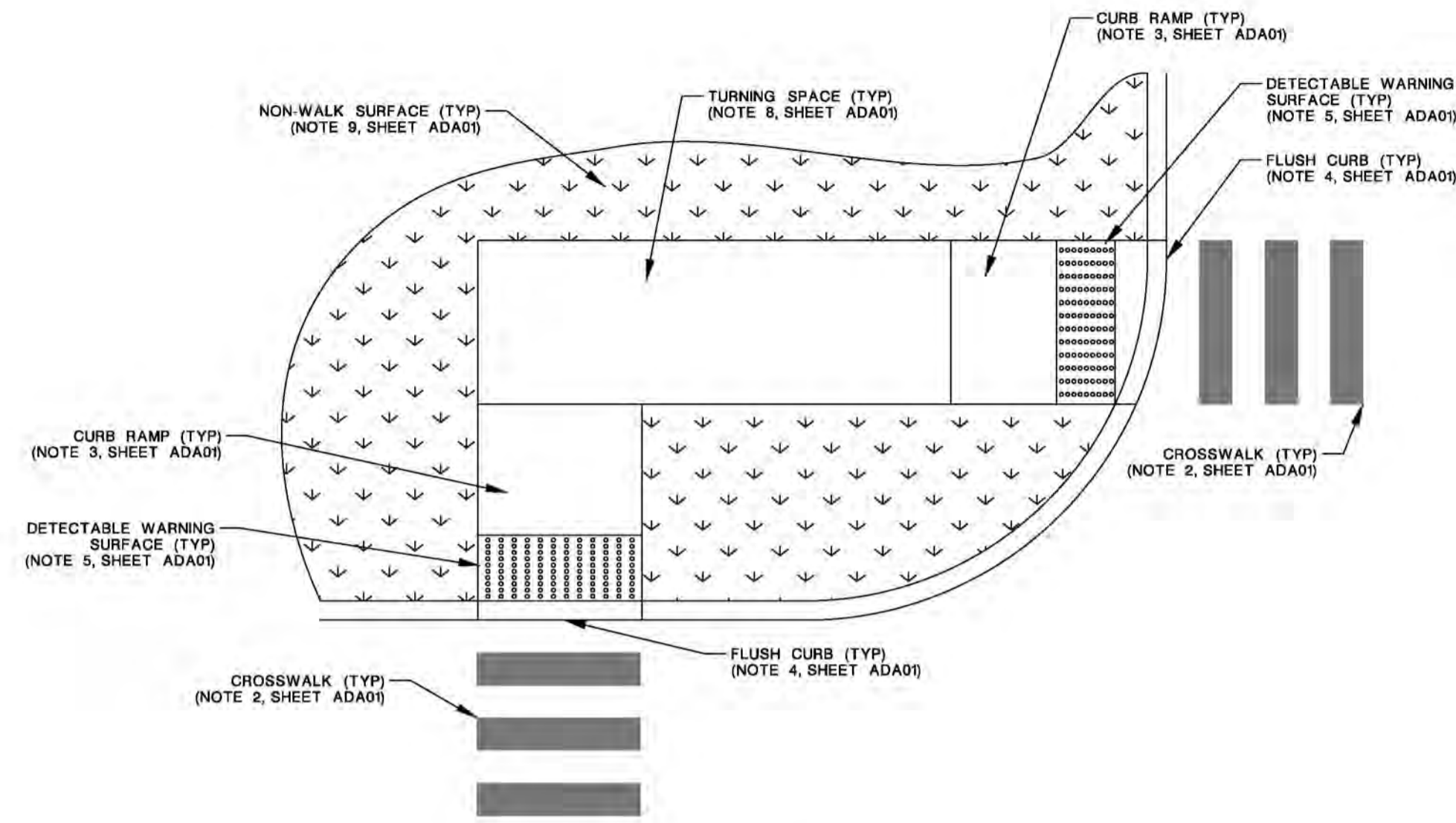

TYPE 2J CURB RAMP

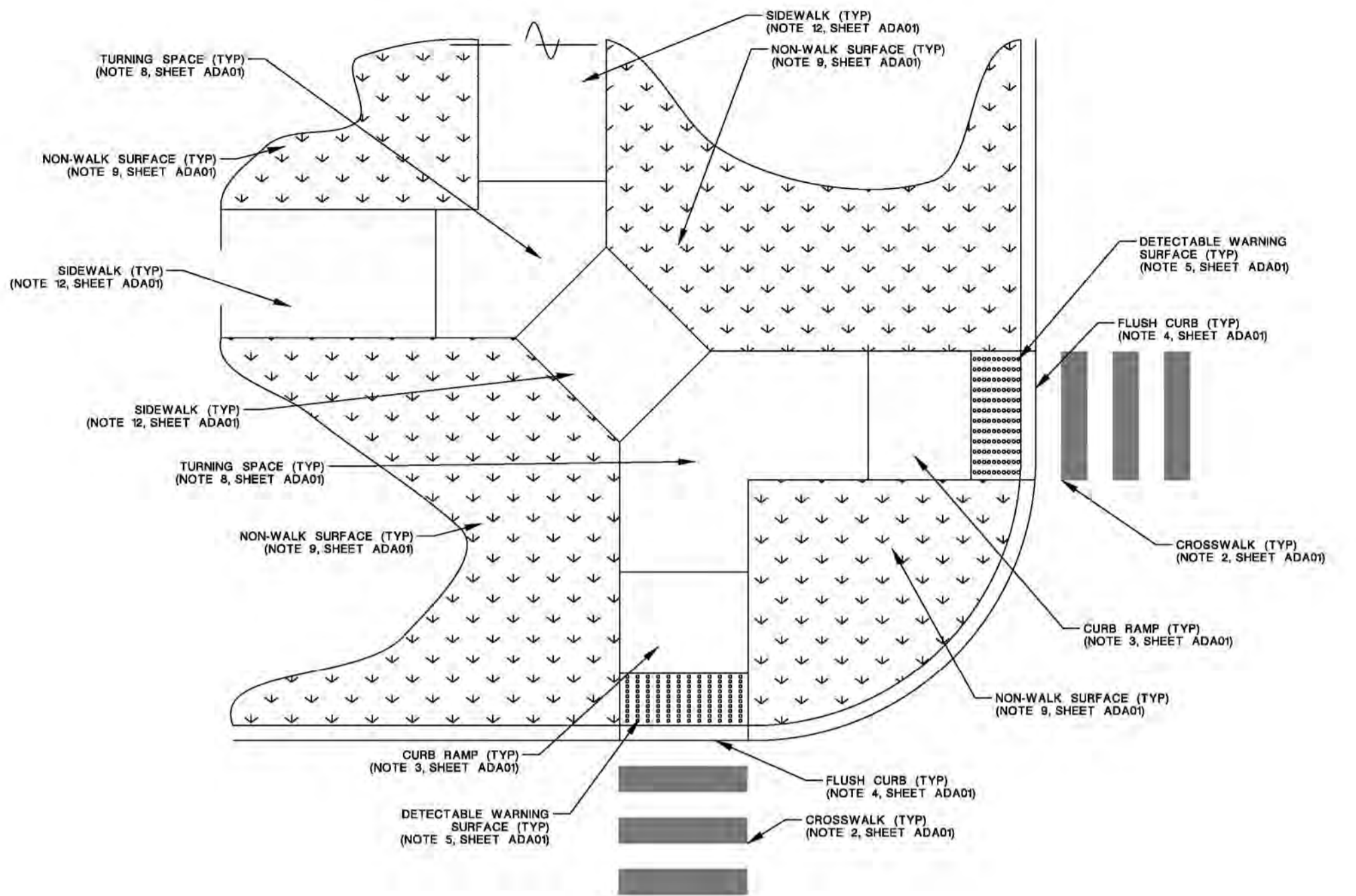

TYPE 2K CURB RAMP

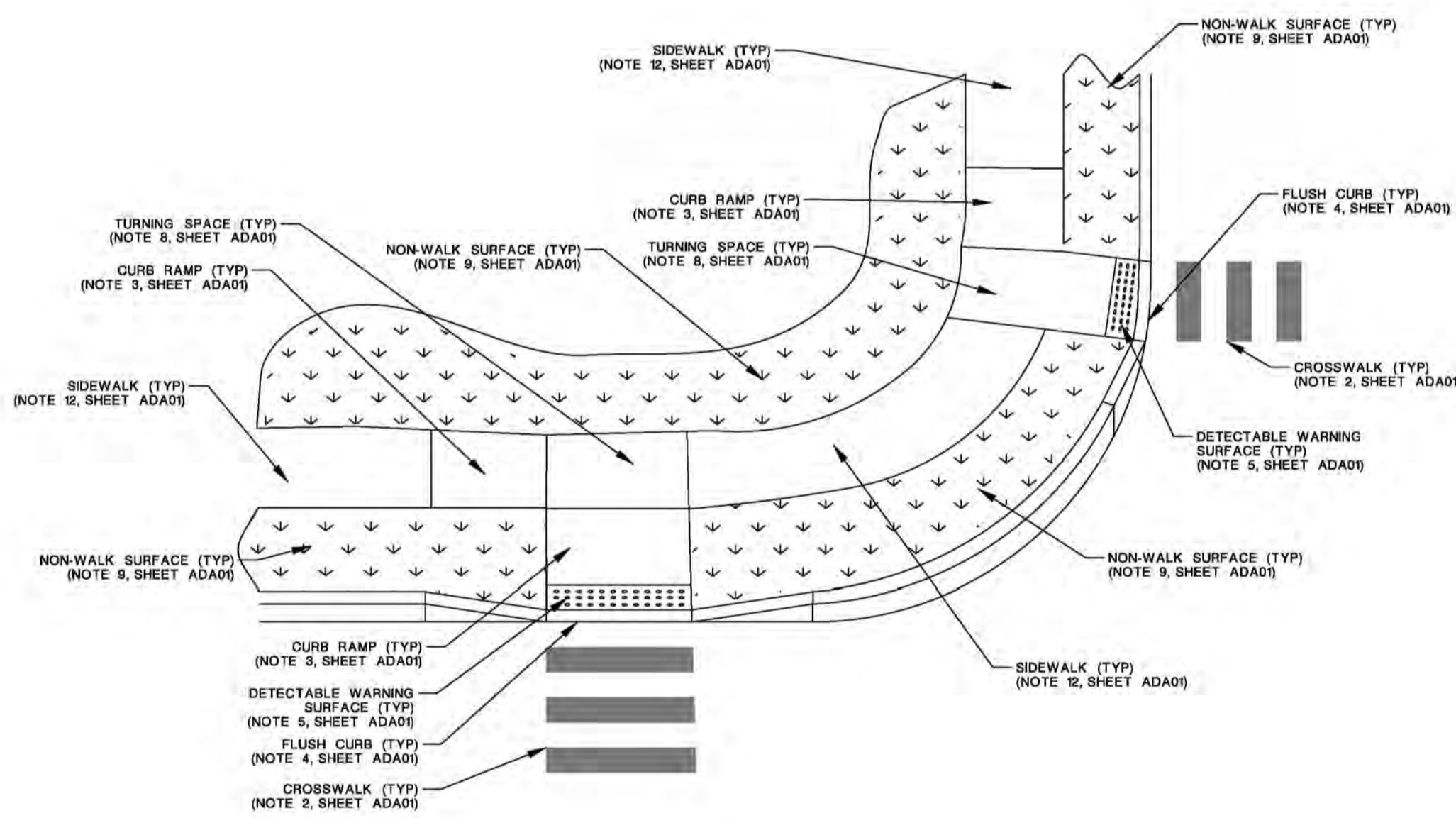

TYPE 2L CURB RAMP

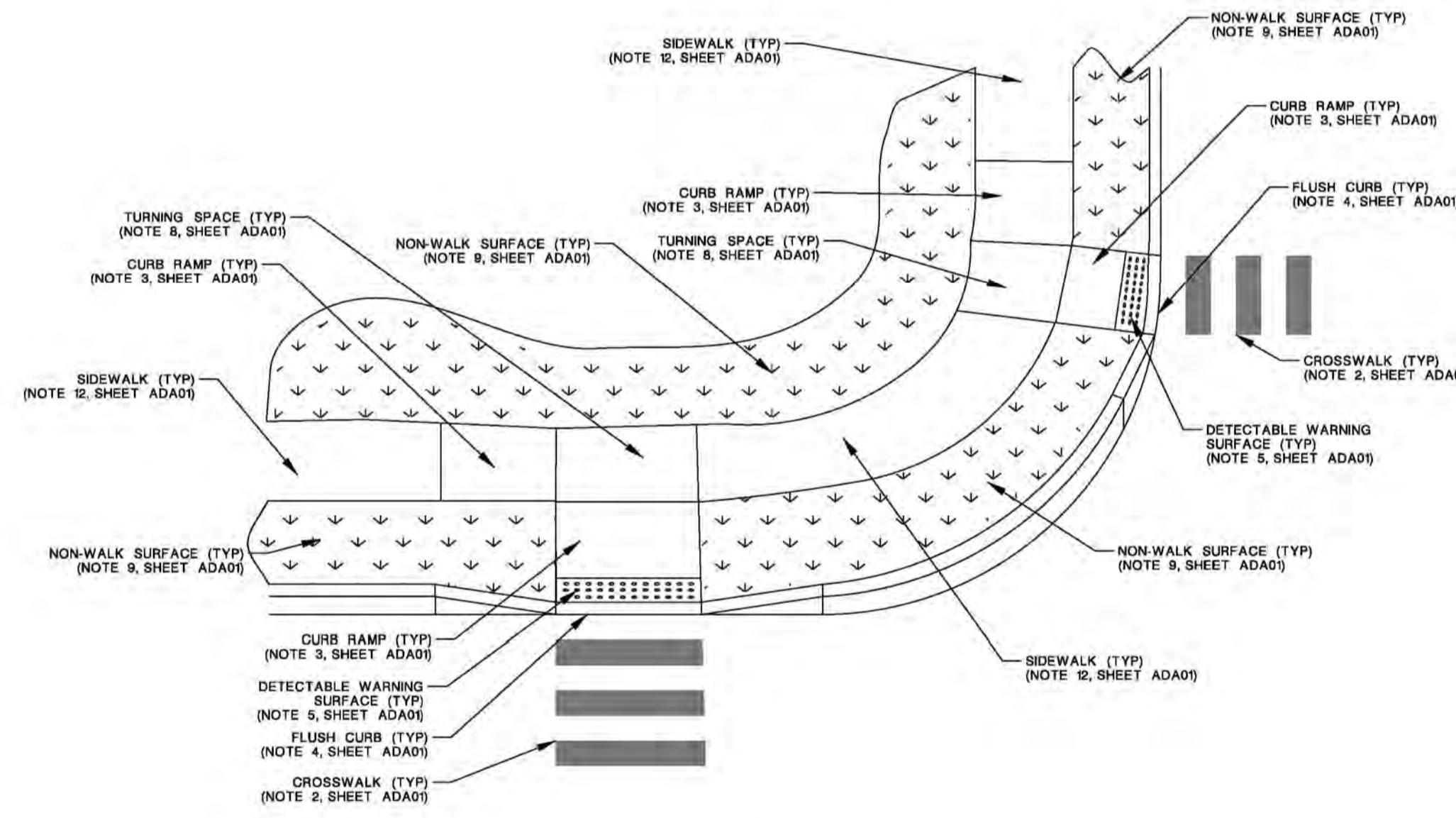

TYPE 2M CURB RAMP

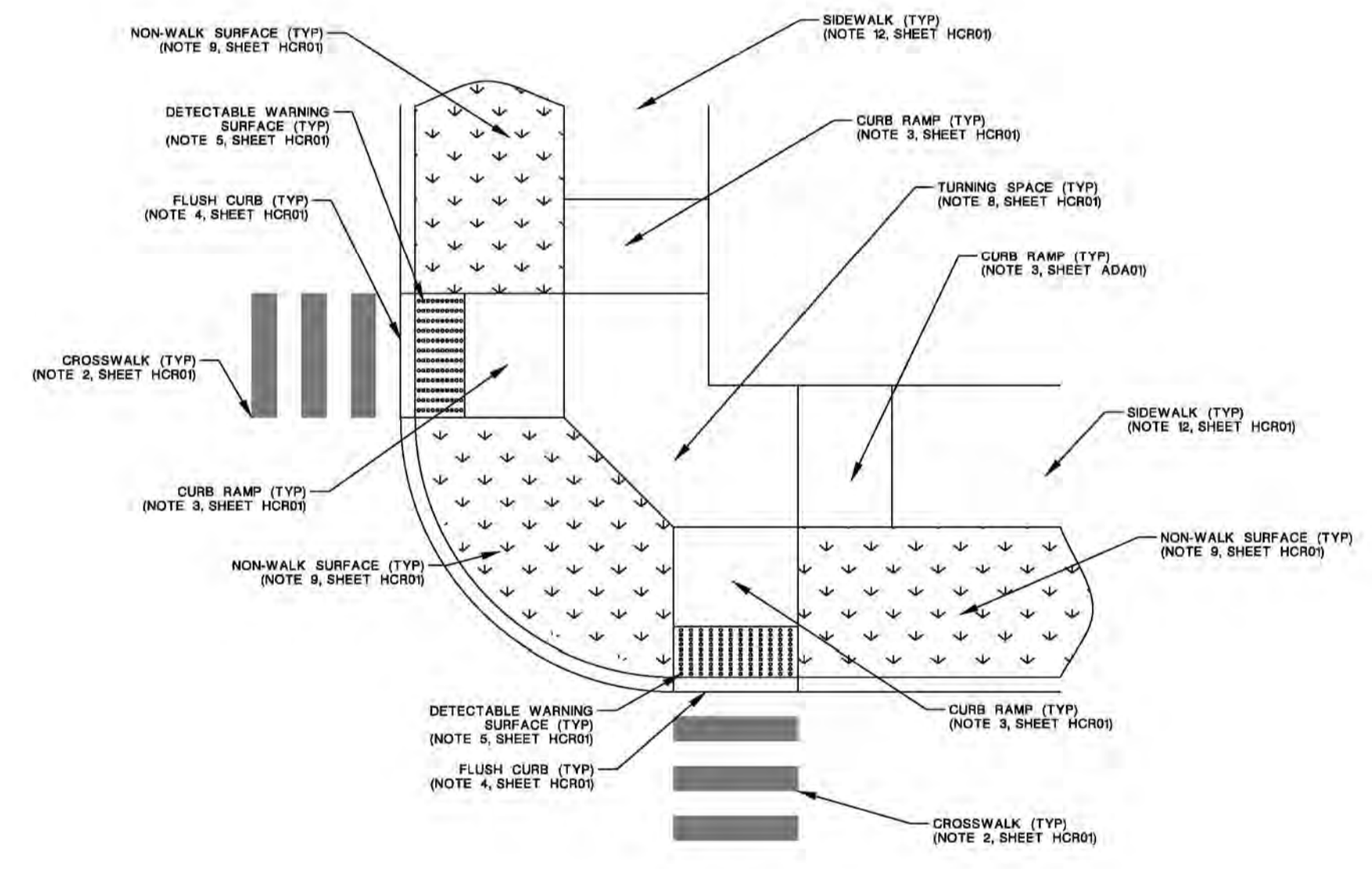

TYPE 2N CURB RAMP

CURB RAMPS AND SIDEWALKS

TYPE 2

DATE	REVISIONS	BY	CHK.
DETAILS FOR			
OCEAN COUNTY			
ADA DETAILS & SPECIFICATIONS			
ADA CURB RAMP DETAILS			
DATE	BY	DESIGNED	CHECKED
SCALE	N.T.S.	DRAWN	APPROVED
 JOHN N. ERNST COUNTY ENGINEER			SHEET 8 OF 28
P.E. No. 33347			

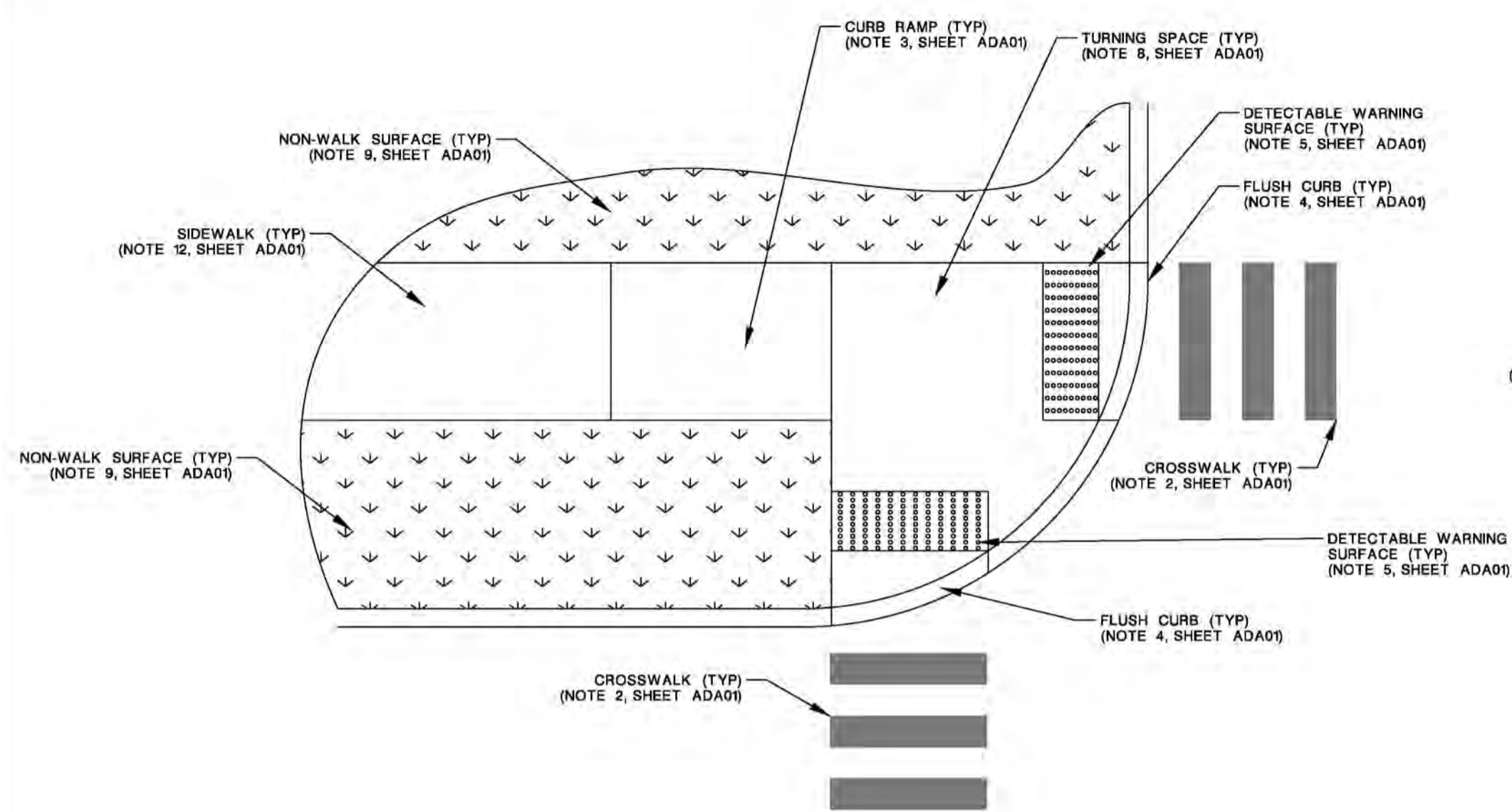

**TYPE 2P
CURB RAMP**

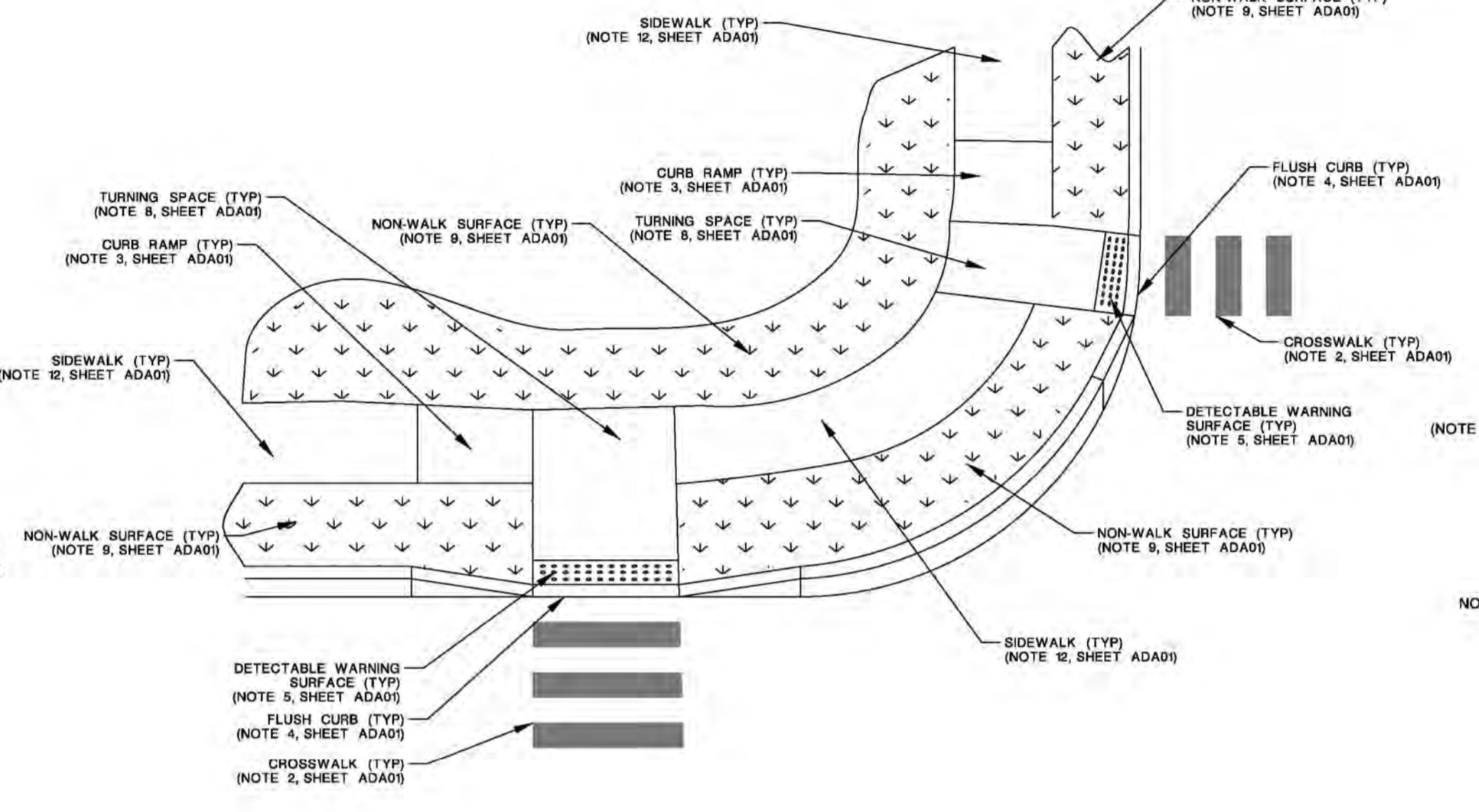

**TYPE 2Q
CURB RAMP**

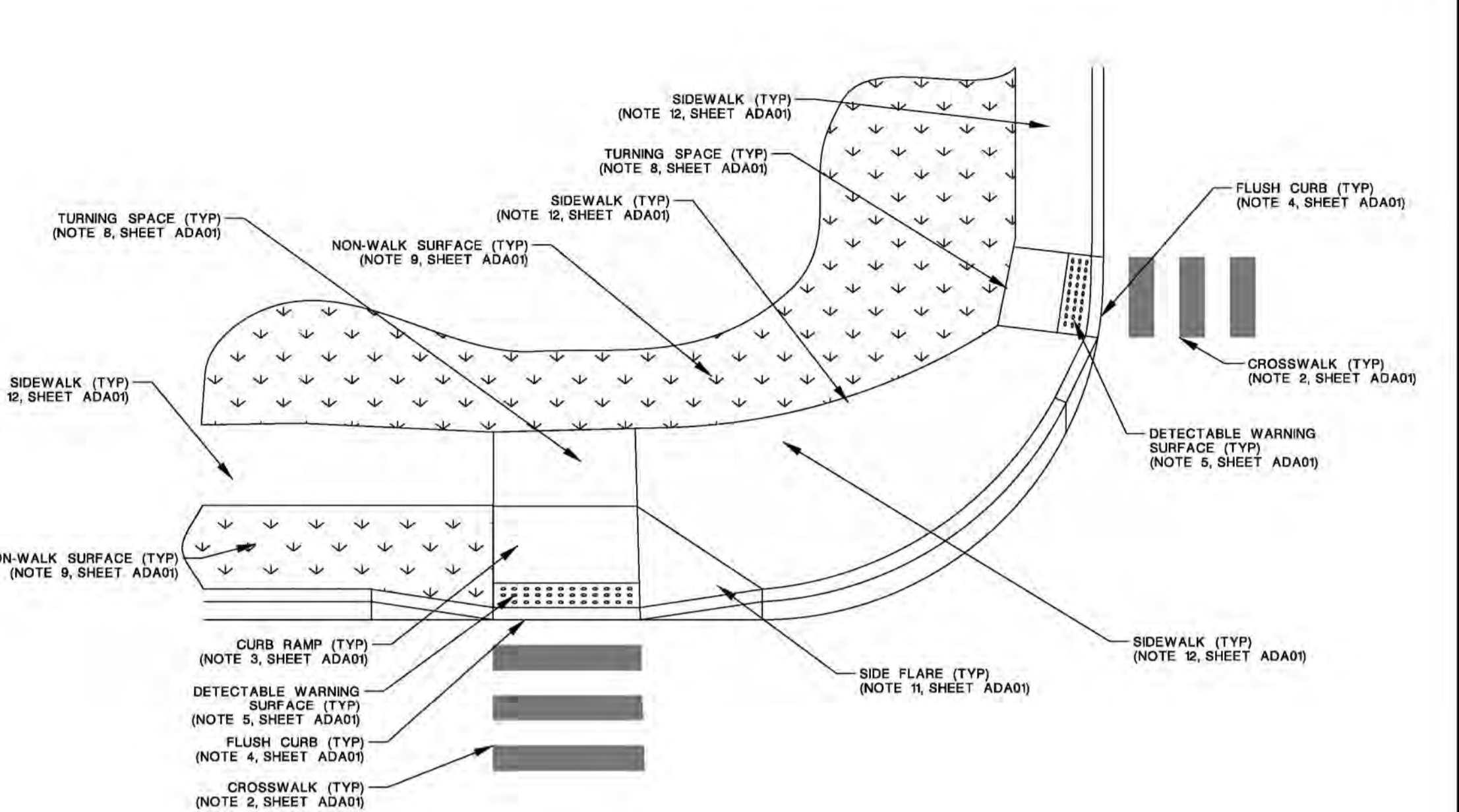

**TYPE 2R
CURB RAMP**

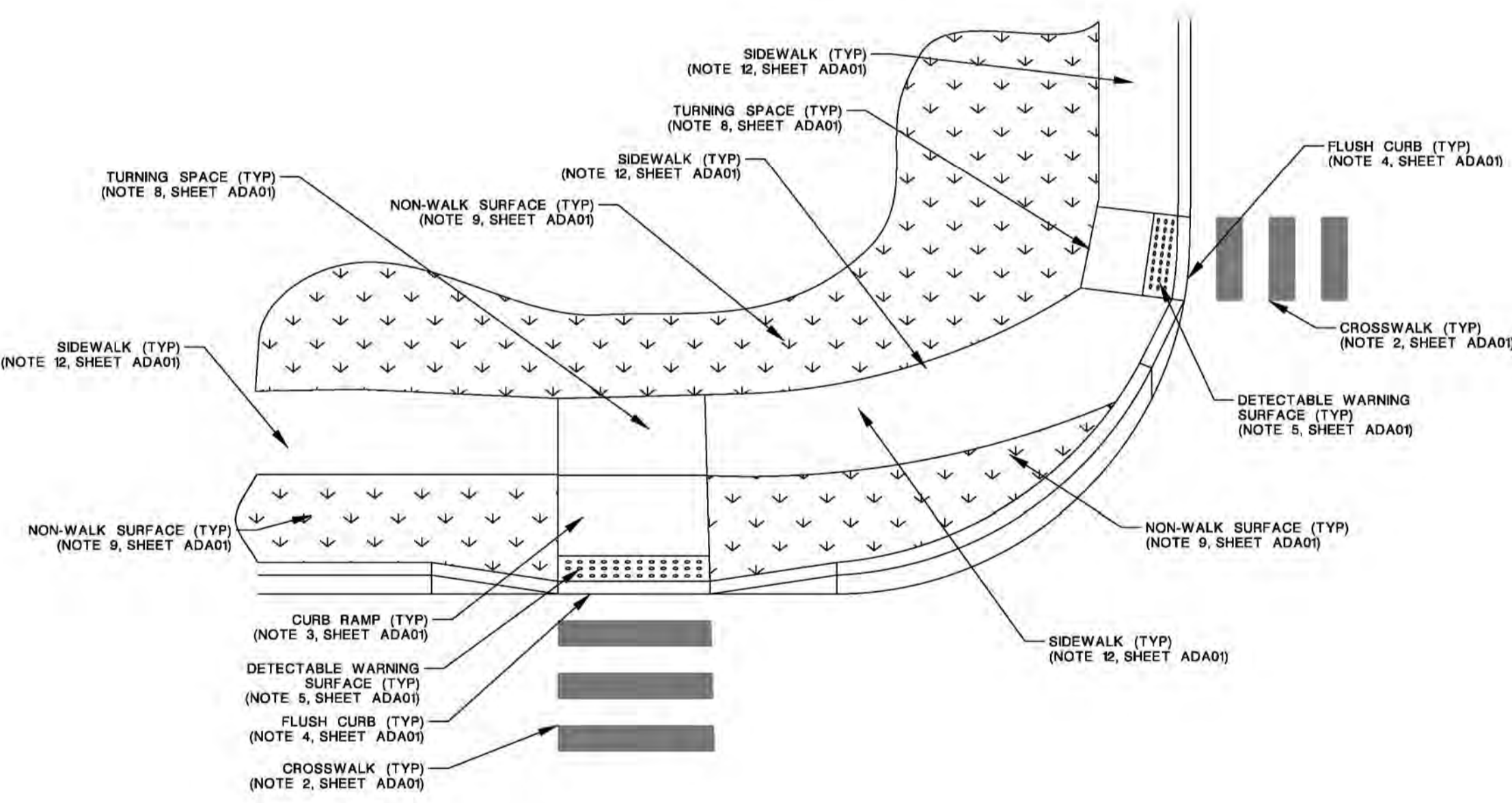

**TYPE 2S
CURB RAMP**

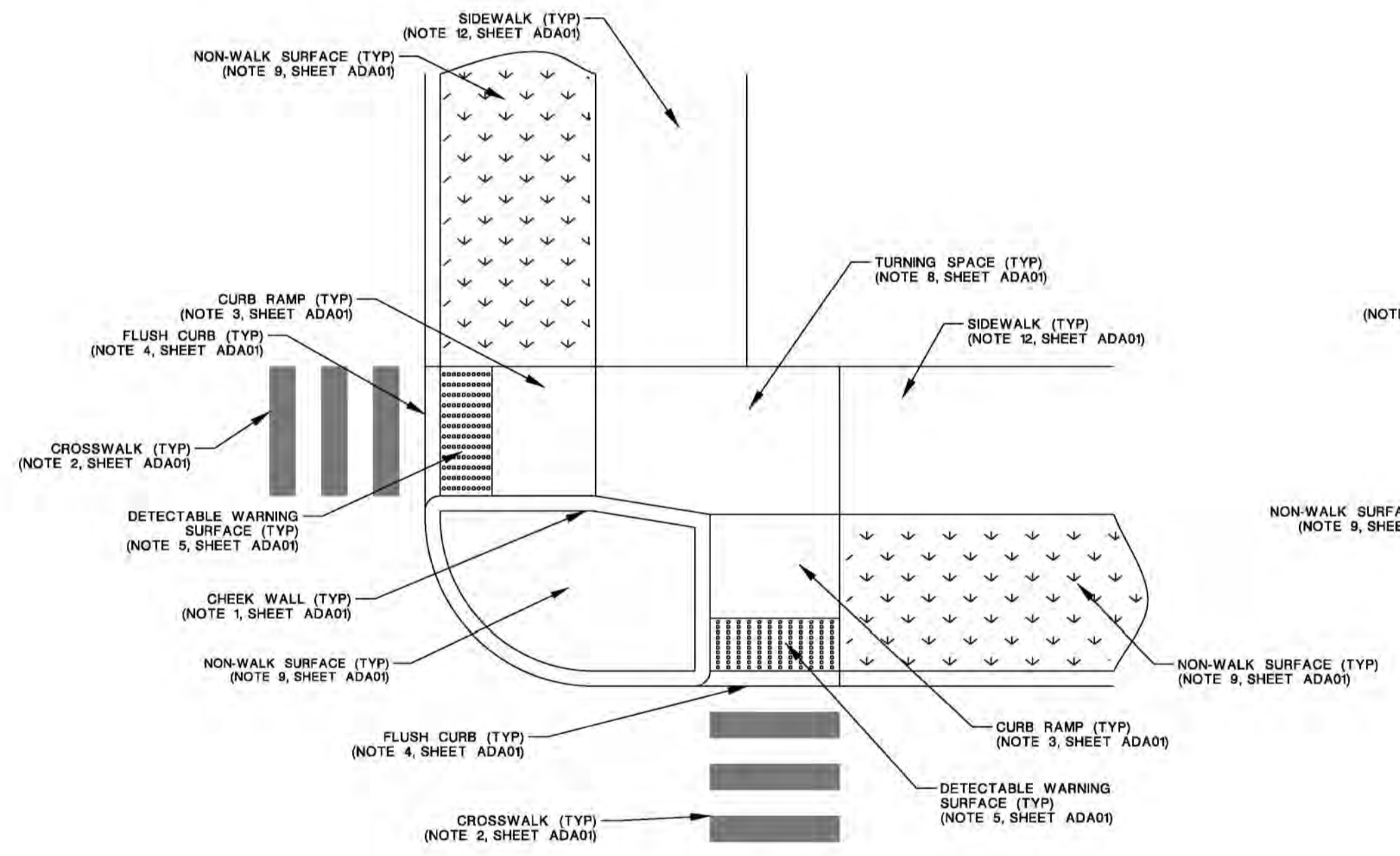

**TYPE 2T
CURB RAMP**

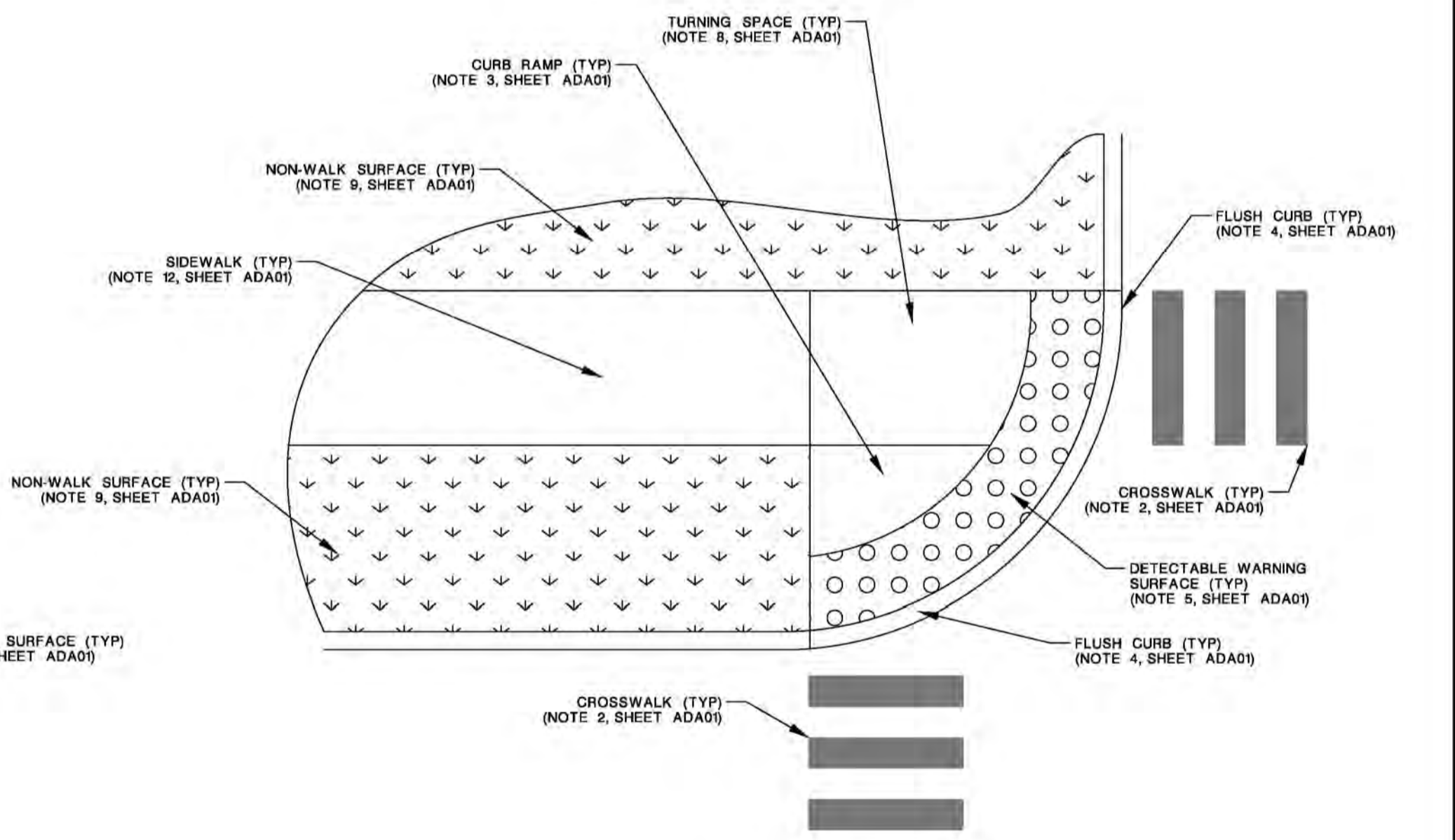

**TYPE 2U
CURB RAMP**

CURB RAMPS AND SIDEWALKS

TYPE 2

DATE	REVISIONS	BY	CHK.
 OCEAN COUNTY ADA DETAILS & SPECIFICATIONS JOHN N. ERNST COUNTY ENGINEER			
ADA CURB RAMP DETAILS			
DATE	BY	DESIGNED	CHECKED
SCALE	N.T.S.	DRAWN	APPROVED
P.E. No. 33347			SHEET OF 28

© 2000 by John N. Ernst, County Engineer, Ocean County, New Jersey. All rights reserved.

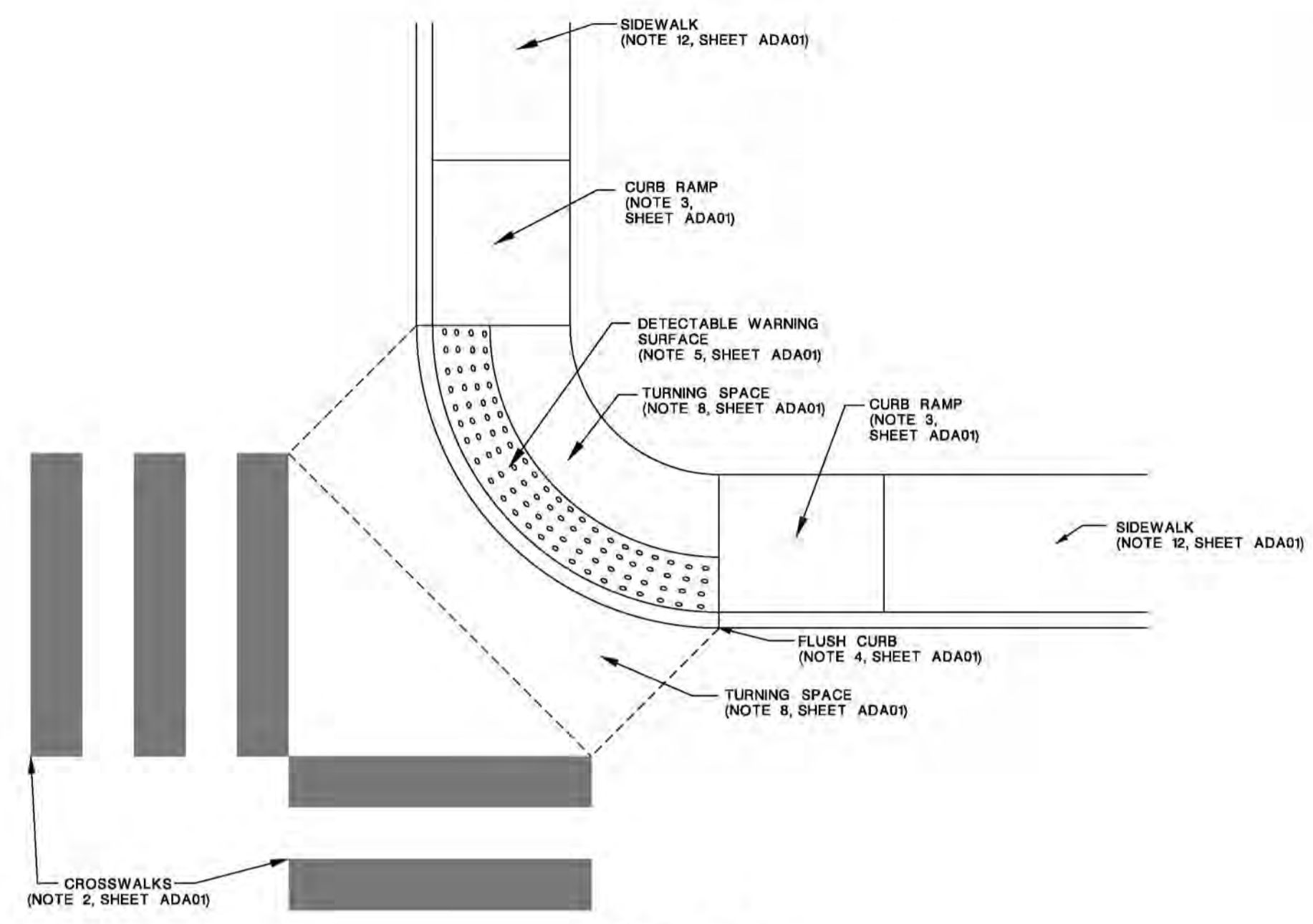

TYPE 3G
BLENDED TRANSITION
 (DIAGONAL - REQUIRES OCEAN COUNTY
 ENGINEERING DEPARTMENT APPROVAL)

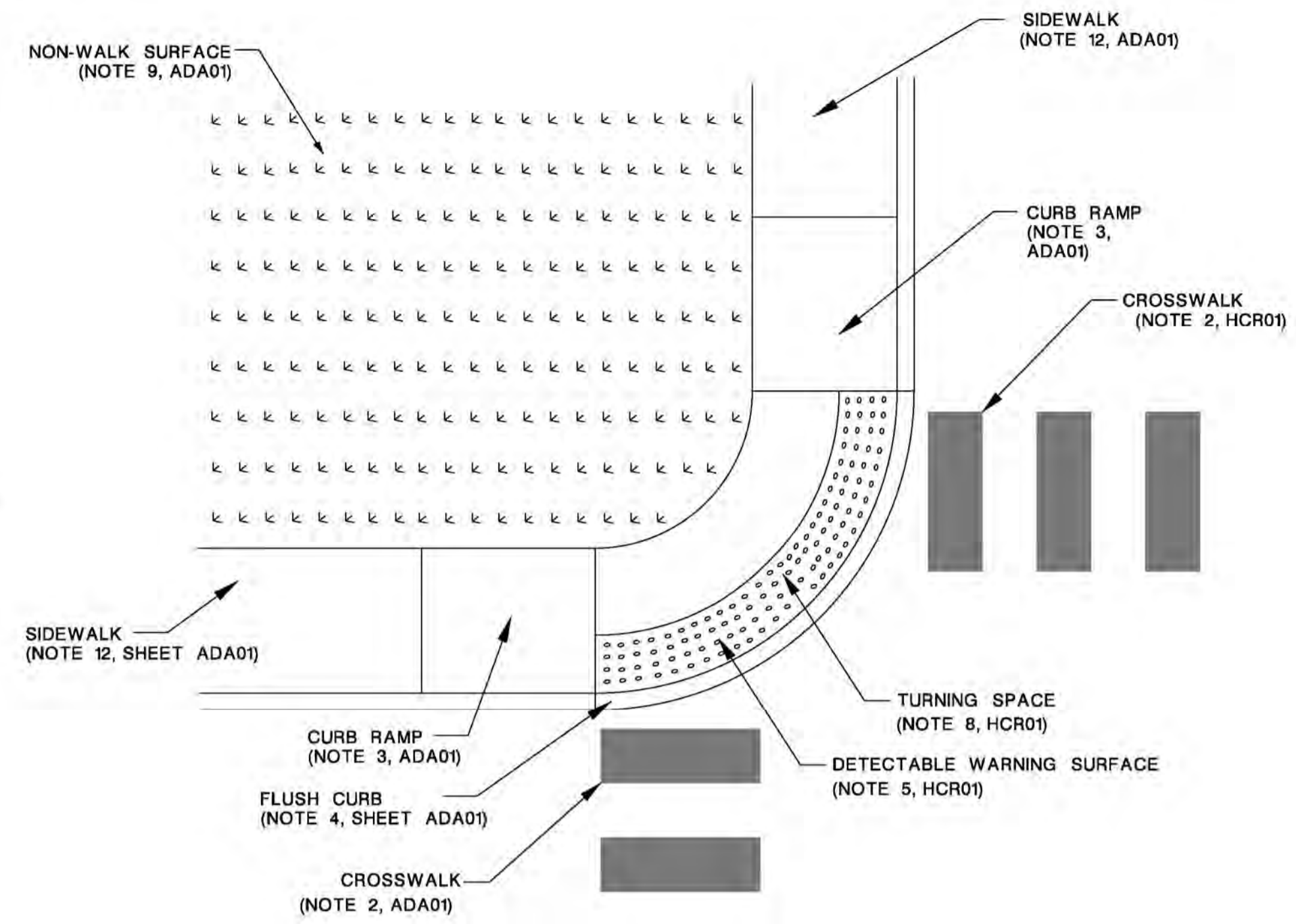

TYPE 3H
BLENDED TRANSITION

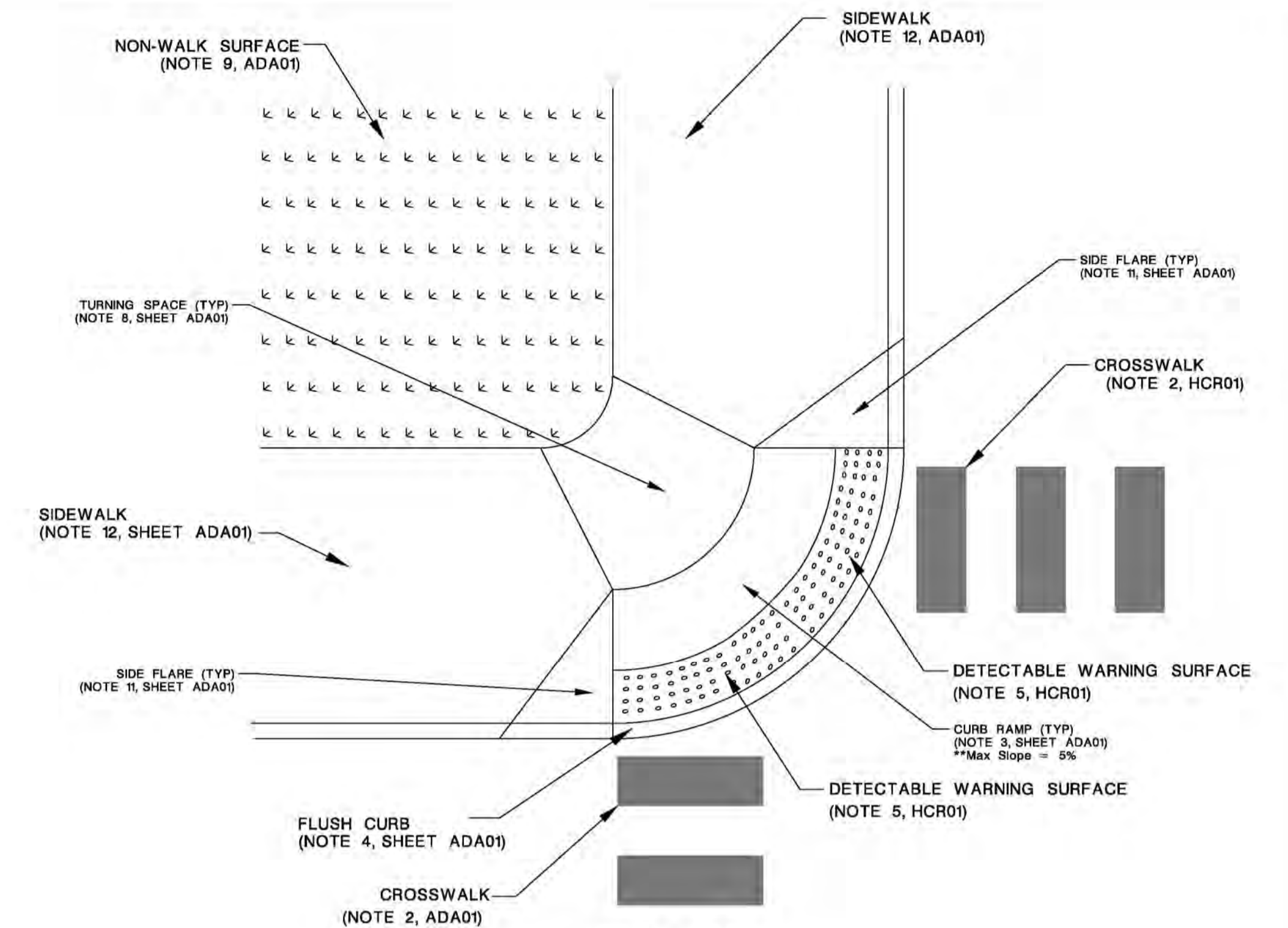

TYPE 3I
BLENDED TRANSITION
 (DIAGONAL - REQUIRES OCEAN COUNTY
 ENGINEERING DEPARTMENT APPROVAL)

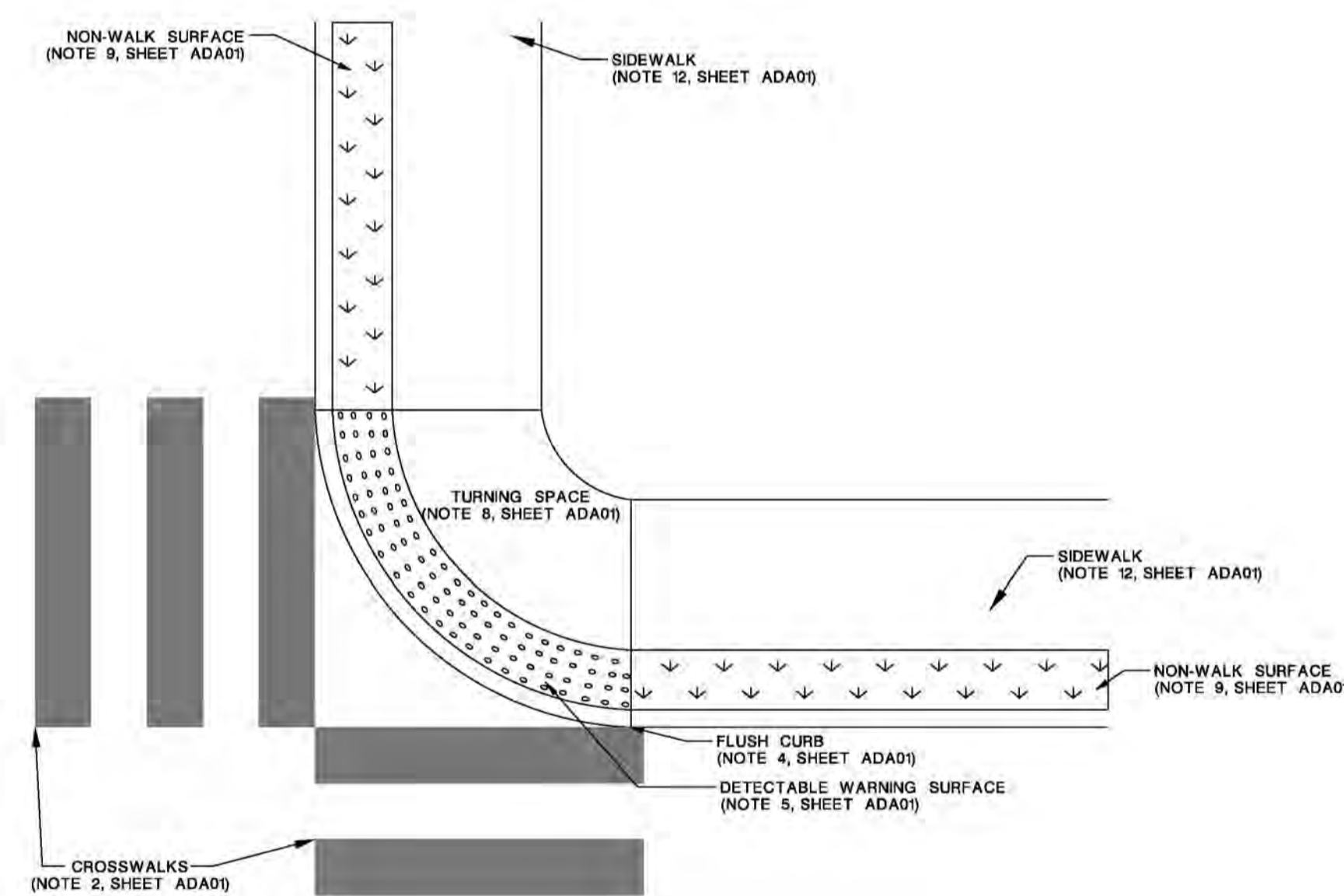

TYPE 3J
BLENDED TRANSITION

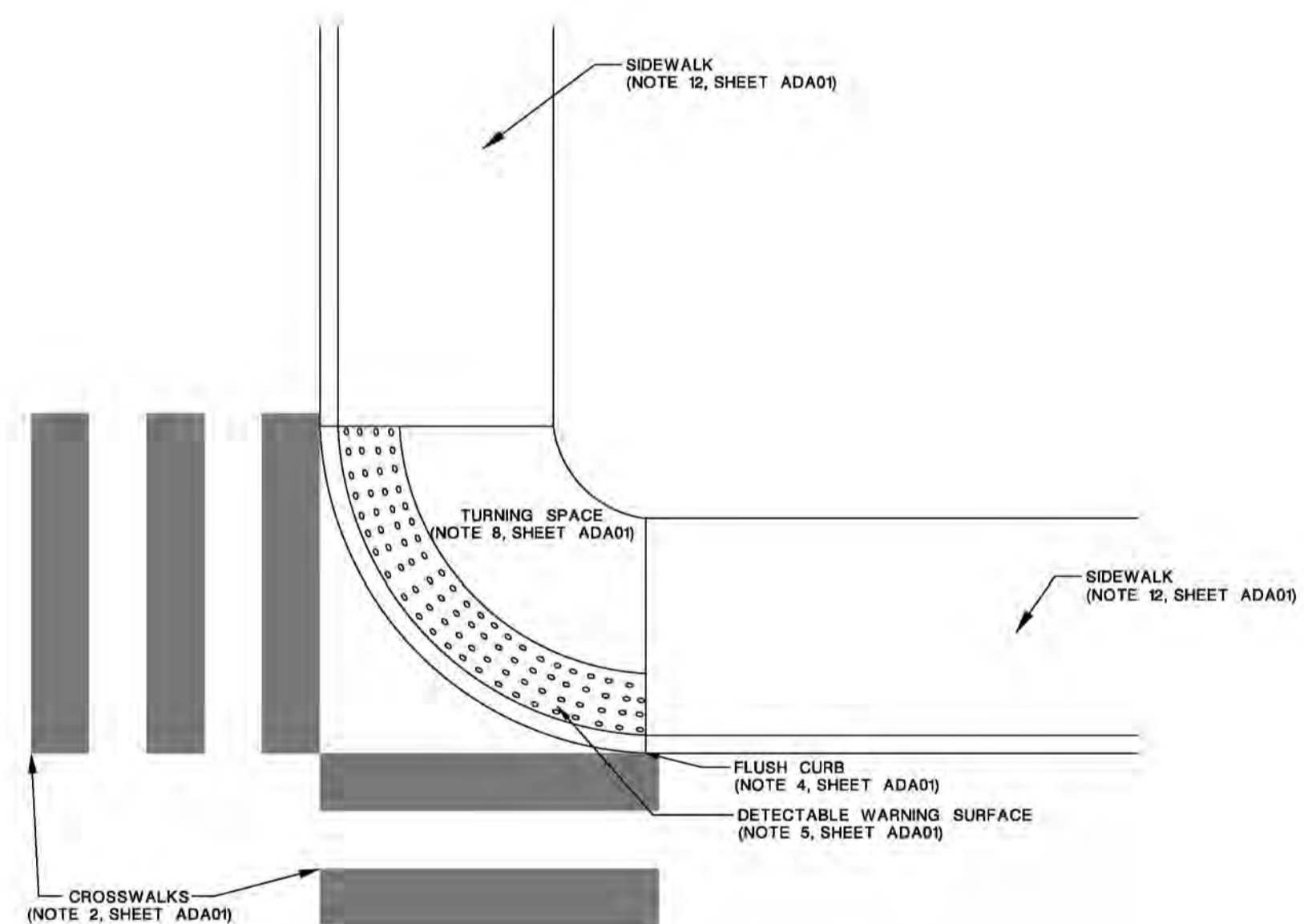

TYPE 3K

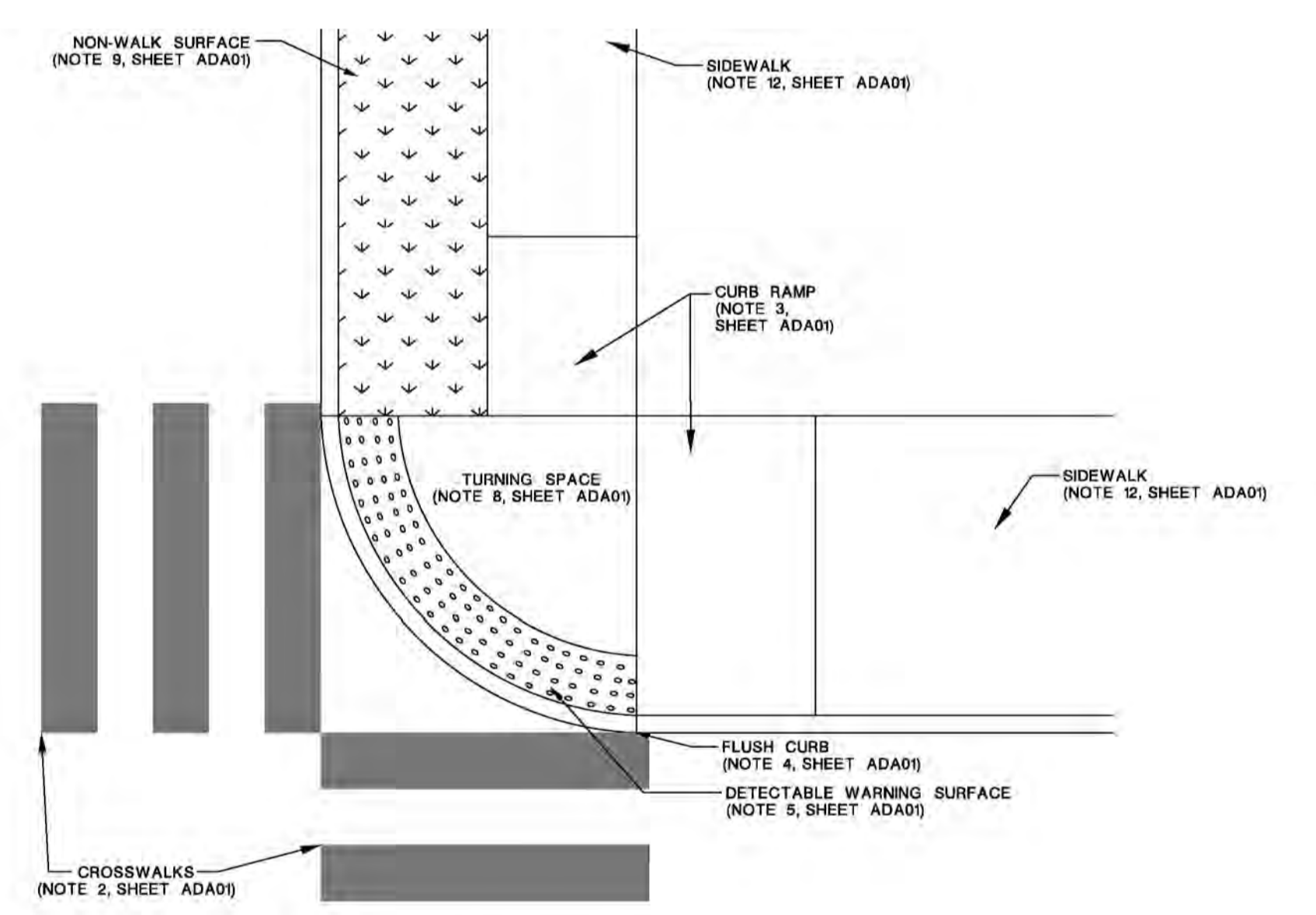

TYPE 3L
BLENDED TRANSITION

CURB RAMPS AND SIDEWALKS

TYPE 3

DATE		REVISIONS		BY		JOB	
 OCEAN COUNTY JOHN N. ERNST COUNTY ENGINEER							
DETAILS FOR OCEAN COUNTY ADA DETAILS & SPECIFICATIONS ADA CURB RAMP DETAILS							
DATE	BY	DESIGNED	***	CHECKED	DATE	APPROVED	F.B.B.
SCALE	N.T.S.	DRAWN	***	APPROVED	FILE NO.	SHEET 9 OF 28	
P.E. No. 33347							

11/15/2017 10:00 AM

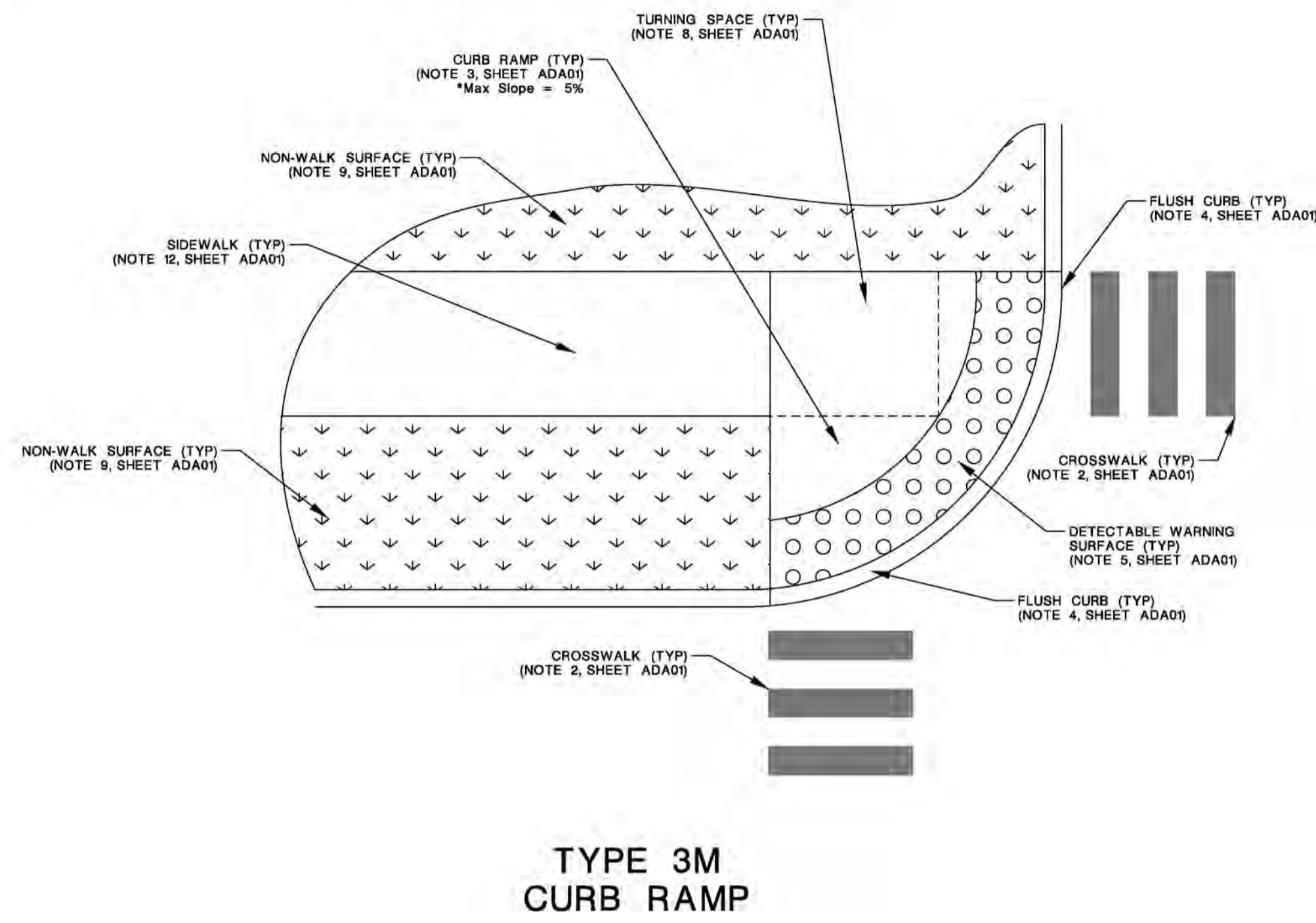

**TYPE 3M
CURB RAMP**

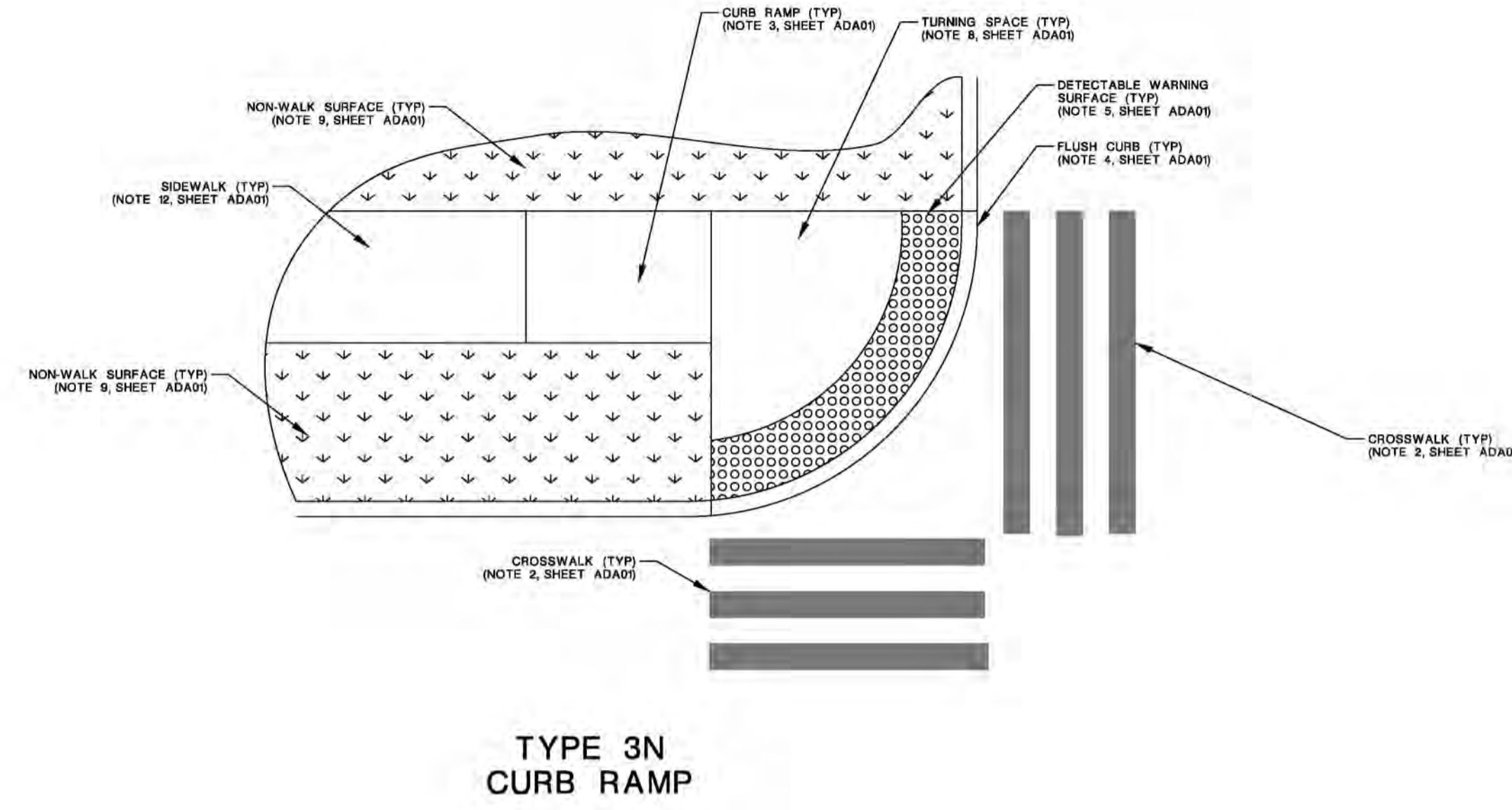

**TYPE 3N
CURB RAMP**

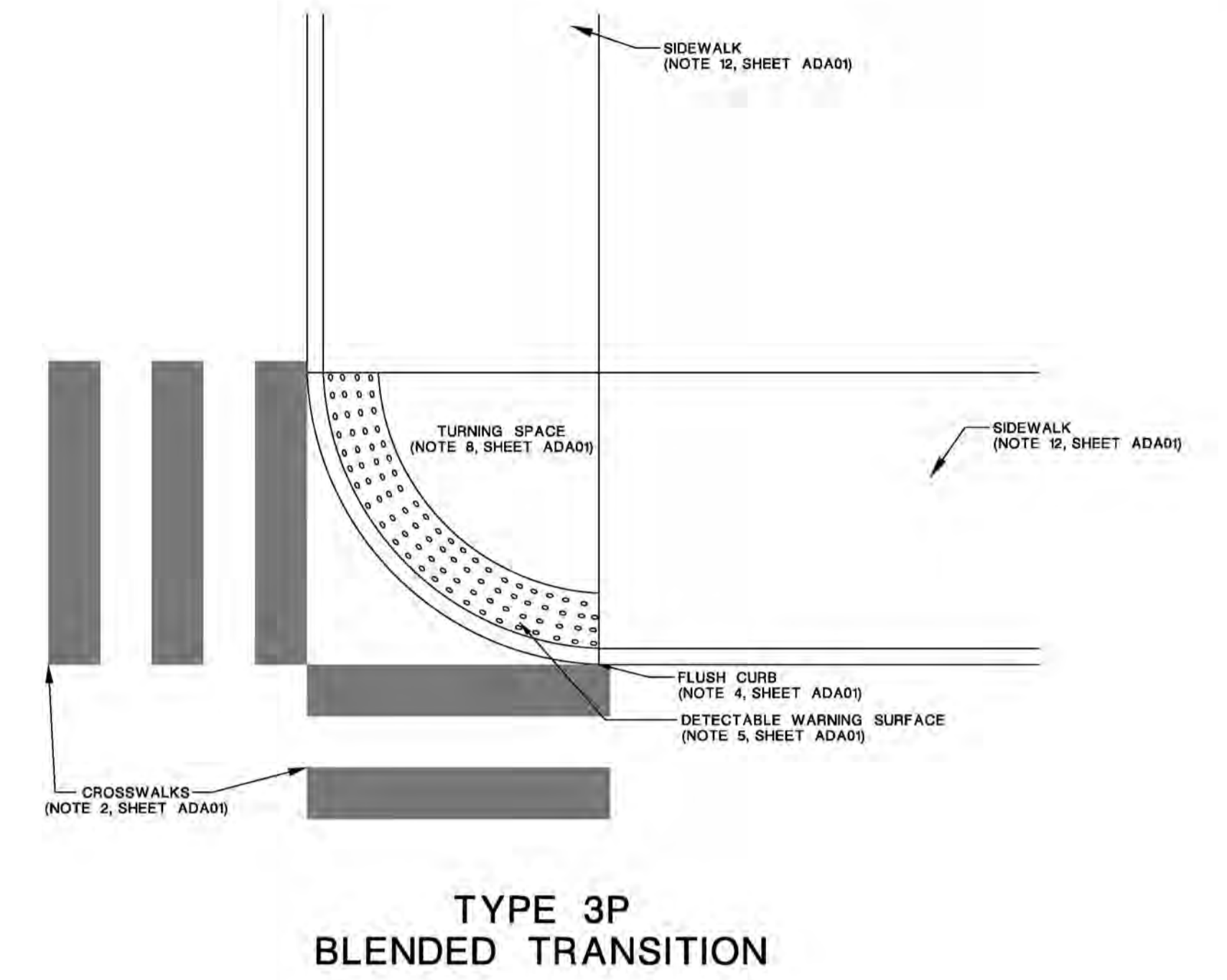

**TYPE 3P
BLENDED TRANSITION**

**CURB RAMPS AND SIDEWALKS
TYPE 3**

DATE	REVISIONS	BY	JOB
DETAILS FOR			
OCEAN COUNTY			
ADA DETAILS & SPECIFICATIONS			
ADA CURB RAMP DETAILS			
DATE	DESIGNED	CHECKED	DRW
SCALE	N.T.S.	DRAWN	APPROVED
			F.S.B.
FILE NO.			SHEET 10 of 28



JOHN N. ERNST
COUNTY ENGINEER

ADA01
ADA23

P.E. No. 33347

11/15/2017 10:00 AM C:\Users\johnd\OneDrive\Documents\170101\170101.dwg

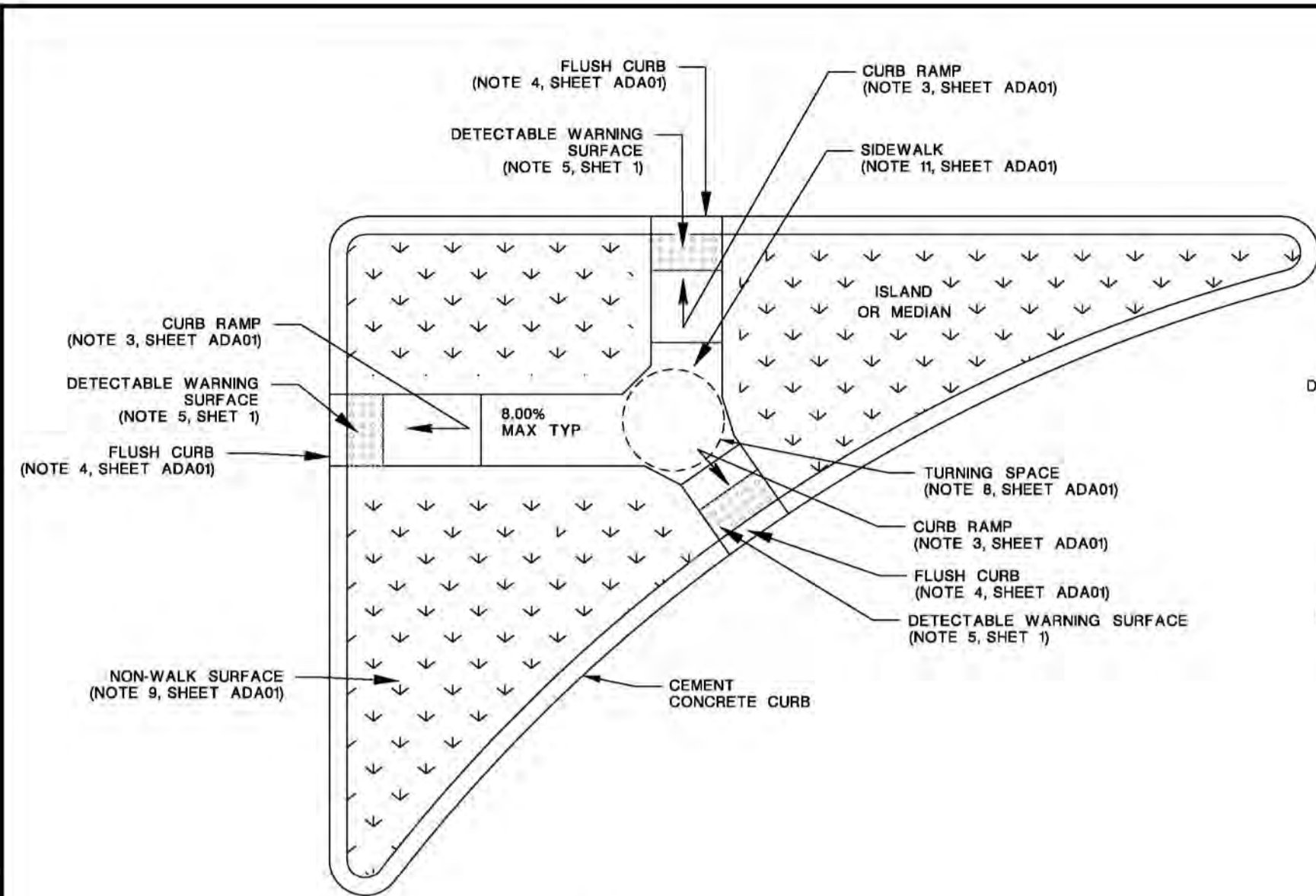

TYPE 4A
MEDIAN OR ISLAND
CURB RAMPS

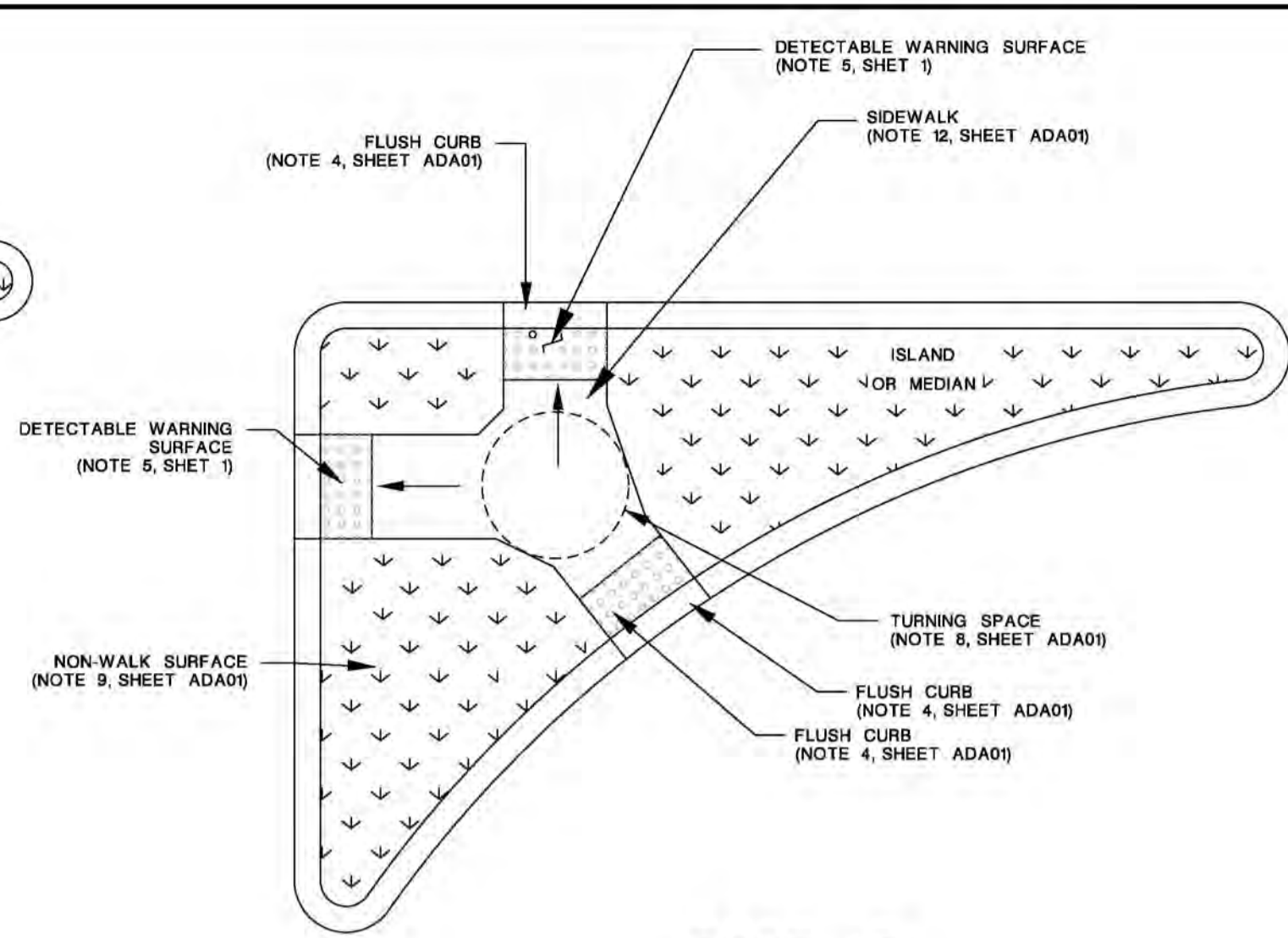

TYPE 4B
ALTERNATE
SMALL ISLAND
WITH CUT THROUGH

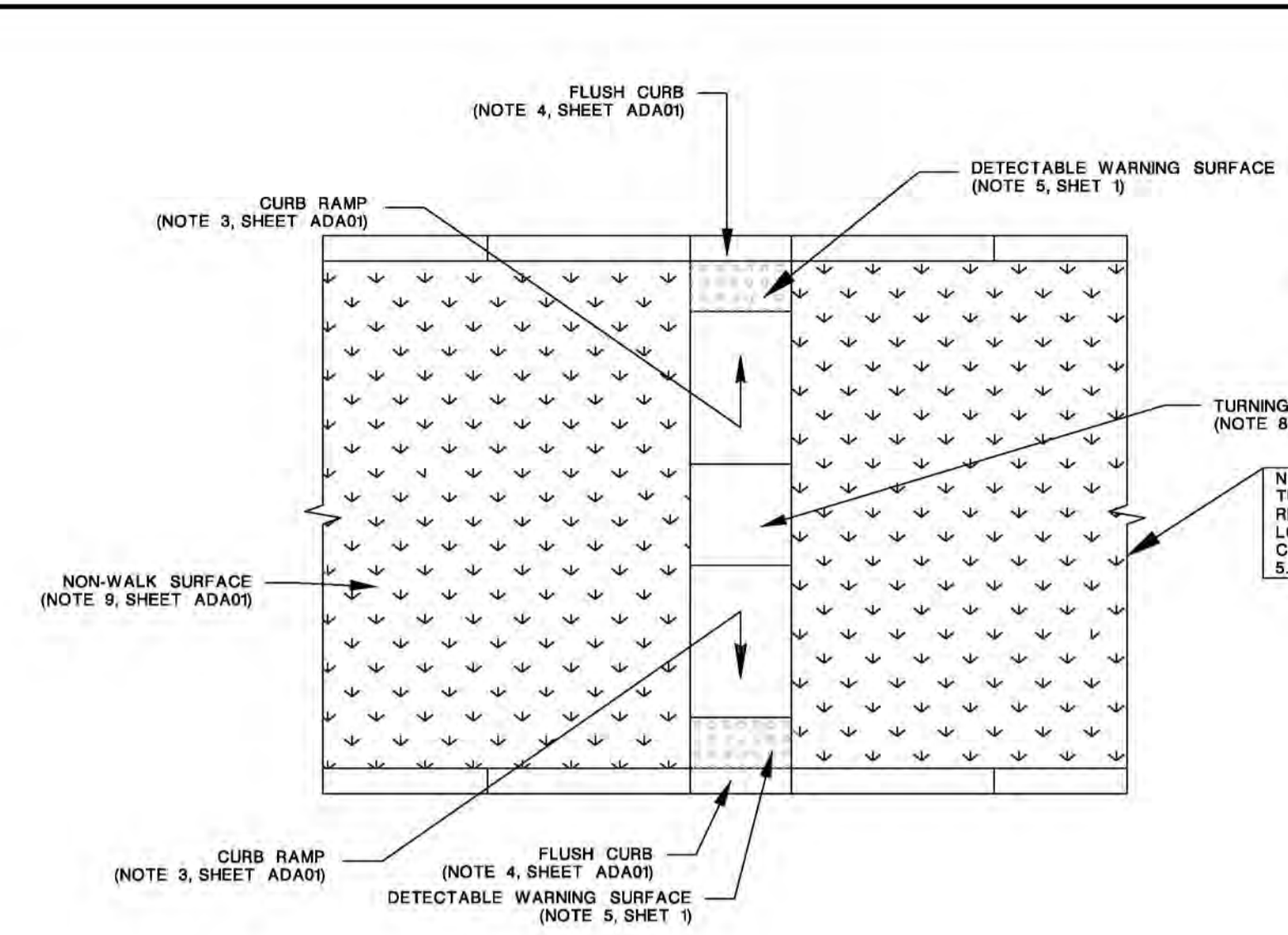

TYPE 4C
DOUBLE CURB RAMPS
RAMPED MEDIAN OR ISLAND
ACCESS OPENING

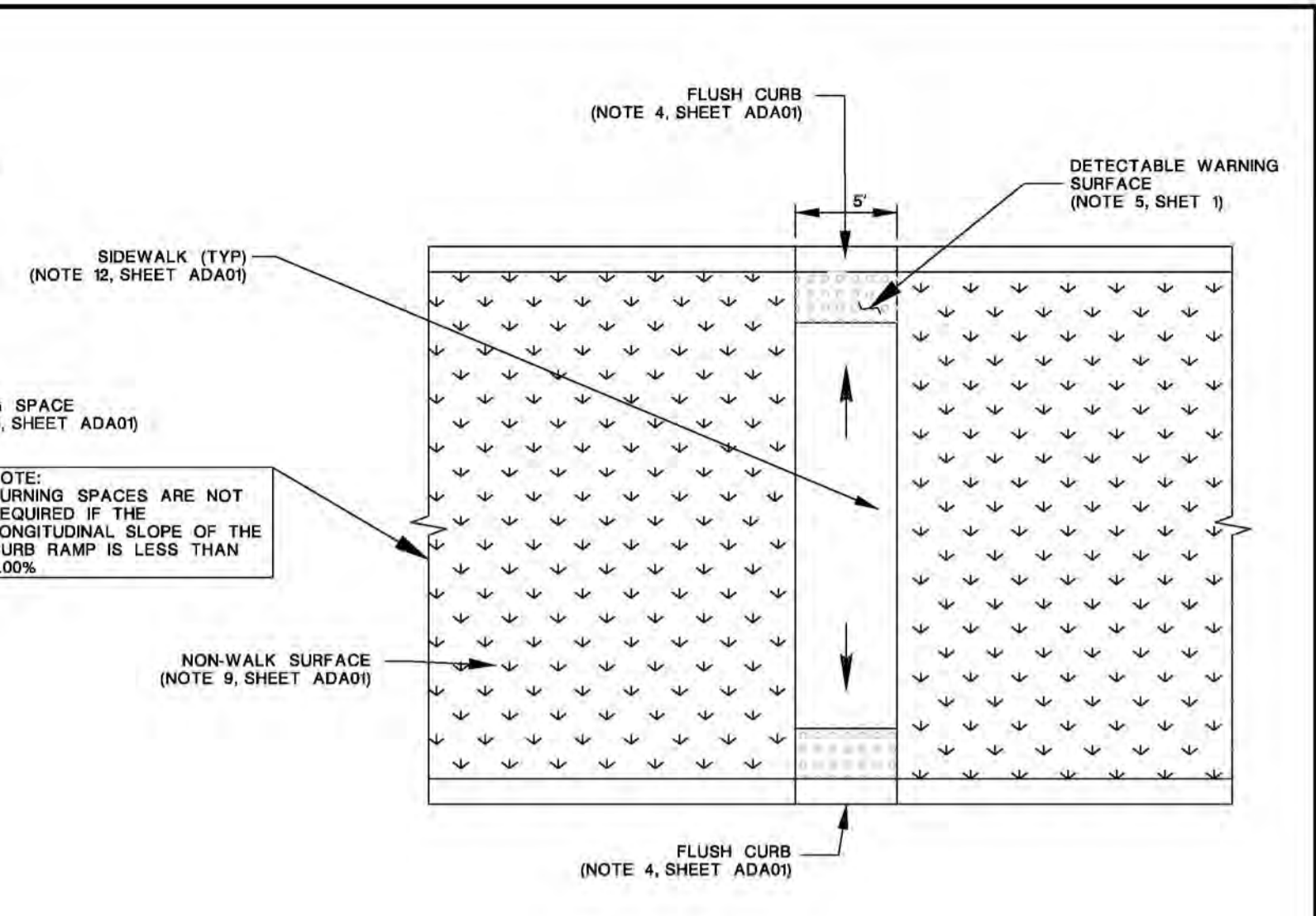

TYPE 4D
DOUBLE CURB RAMPS
RAMPED MEDIAN OR ISLAND
ACCESS OPENING

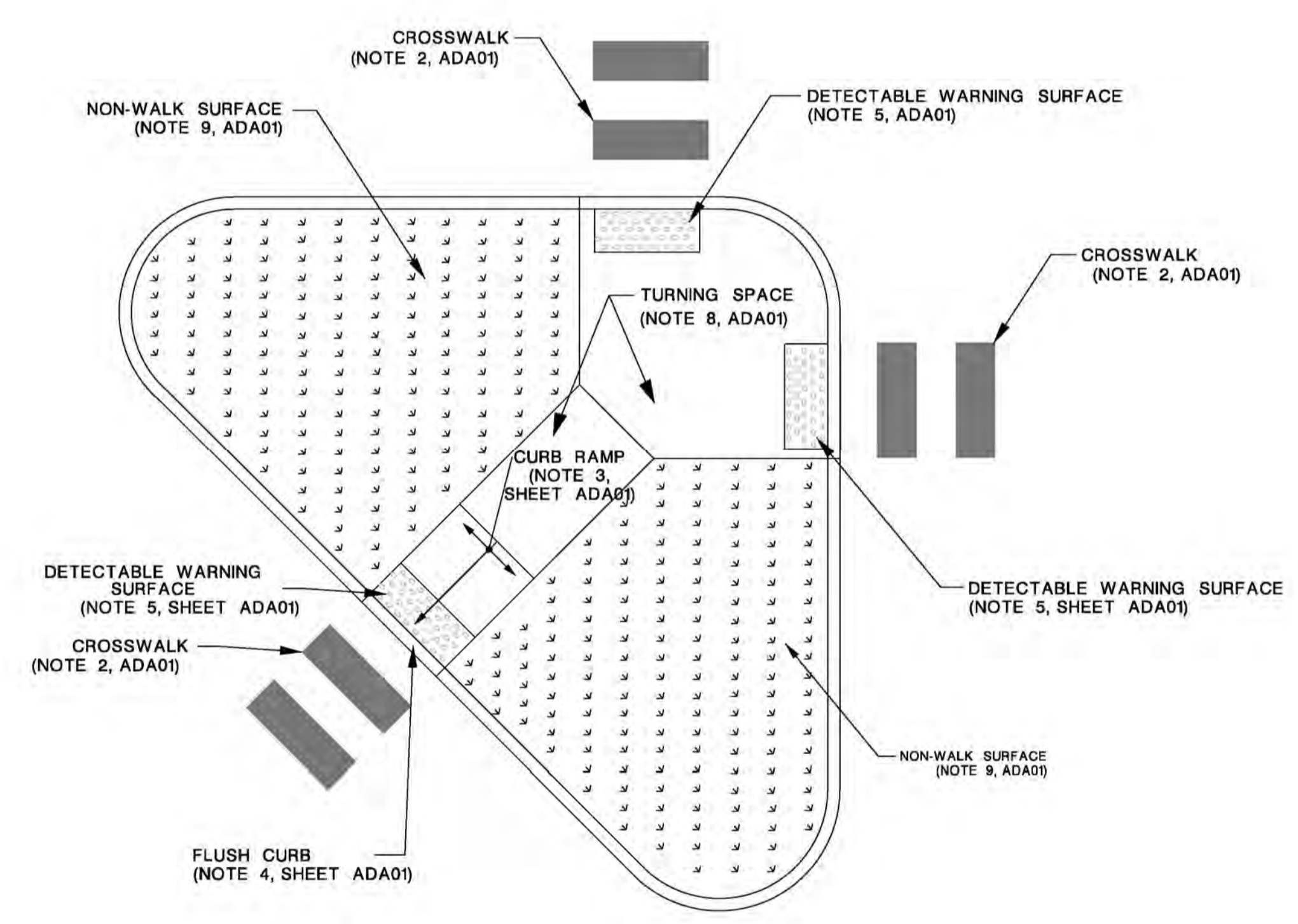

TYPE 4E
ISLAND CURB RAMP

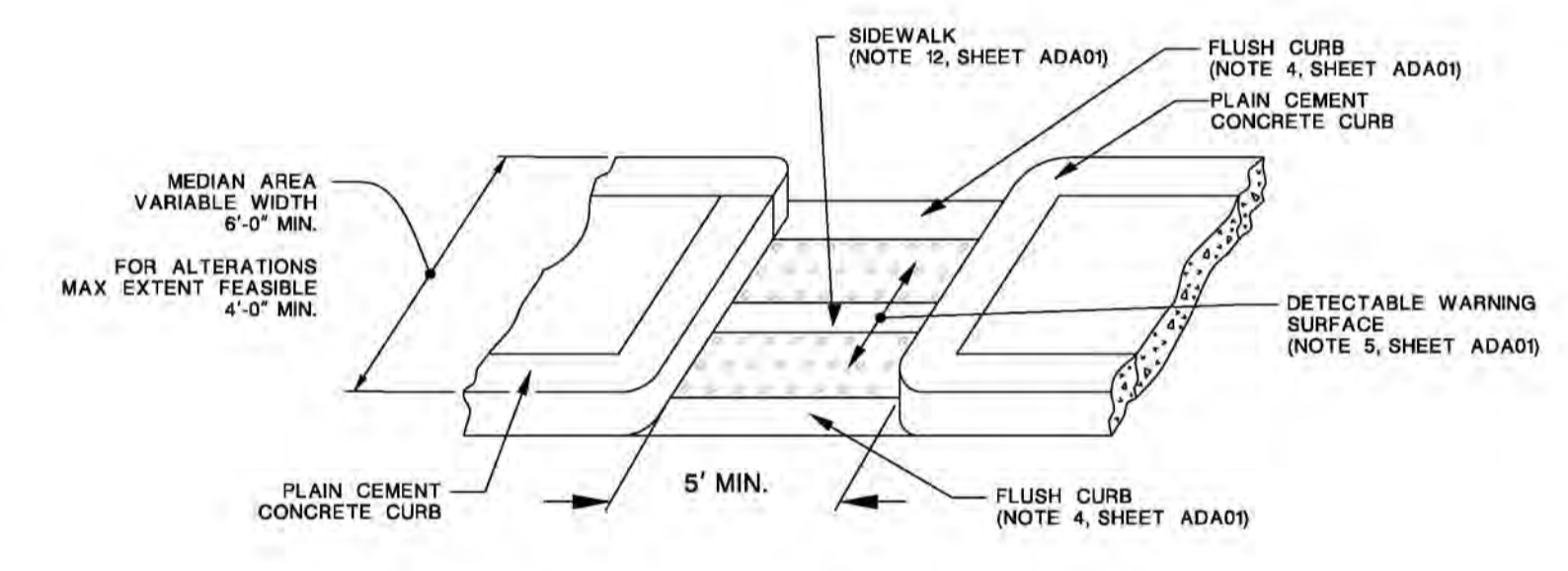

TYPE 4F
TYPICAL MEDIAN OR ISLAND
ACCESS OPENING WITH CURB SIDES
(NARROW MEDIANS)

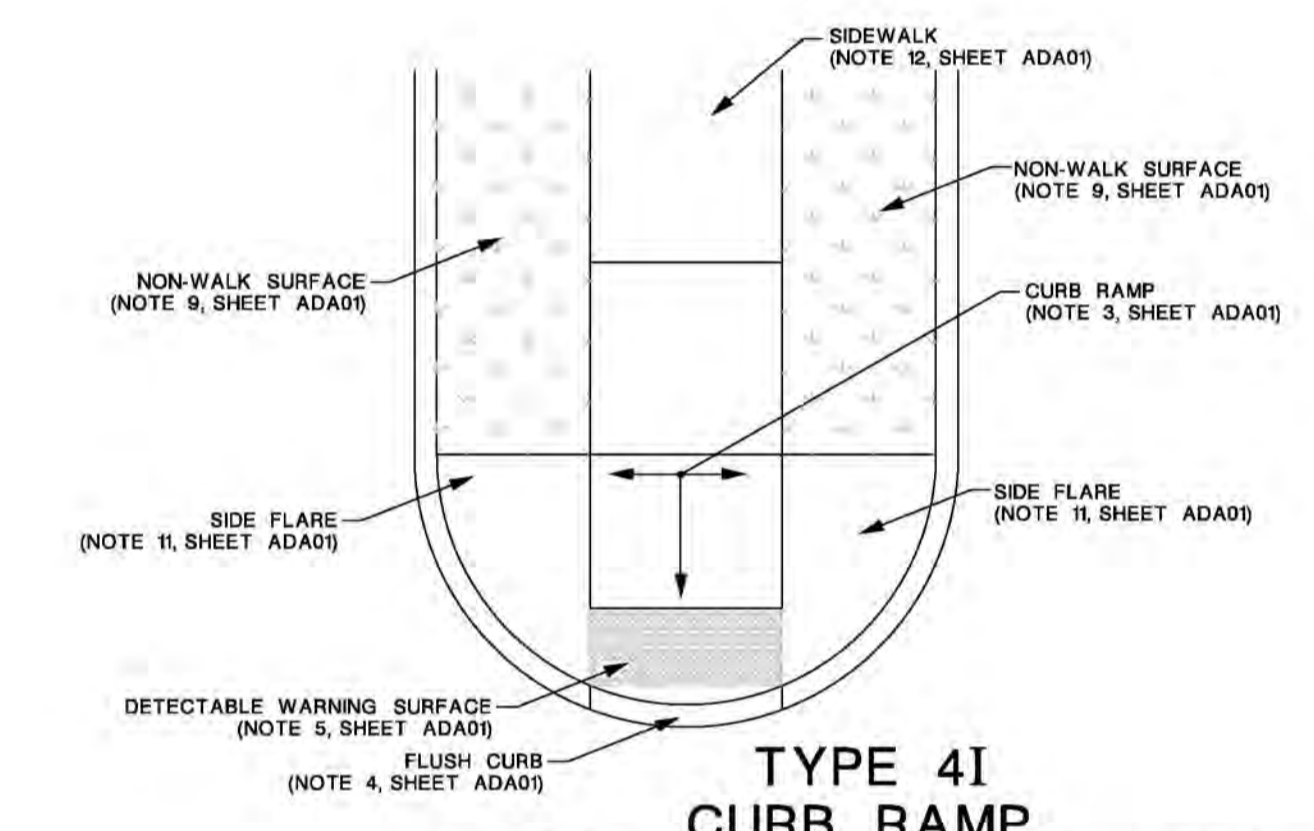

TYPE 4I
CURB RAMP
ACCESS ISLAND CURB RAMP

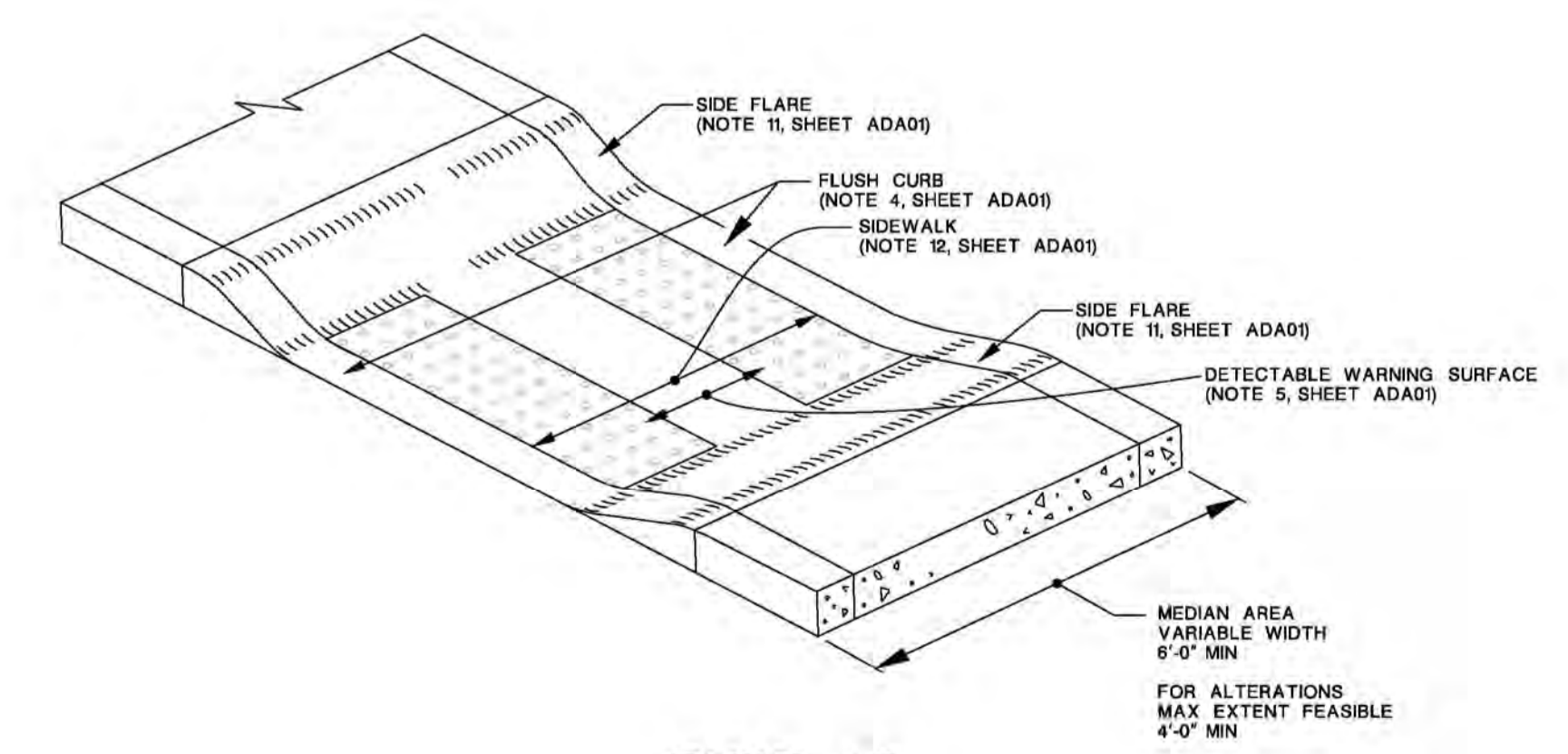

TYPE 4G
TYPICAL MEDIAN OR ISLAND
ACCESS OPENING WITH FLARED SIDES
(NARROW MEDIANS)

CURB RAMPS AND SIDEWALKS

TYPE 4

DATE	REVISIONS	BY	CHK.
DETAILS FOR			
OCEAN COUNTY			
ADA DETAILS & SPECIFICATIONS			
ADA CURB RAMP DETAILS			
DATE	DESIGNED	CHECKED	DRW.
SCALE	N.T.S.	DRAWN	APPROVED
			F.S.S.
P.E. No. 33347			FILE NO. 194
			SHEET 11 OF 23

11/15/2011 10:00 AM 11/15/2011 10:00 AM 11/15/2011 10:00 AM 11/15/2011 10:00 AM

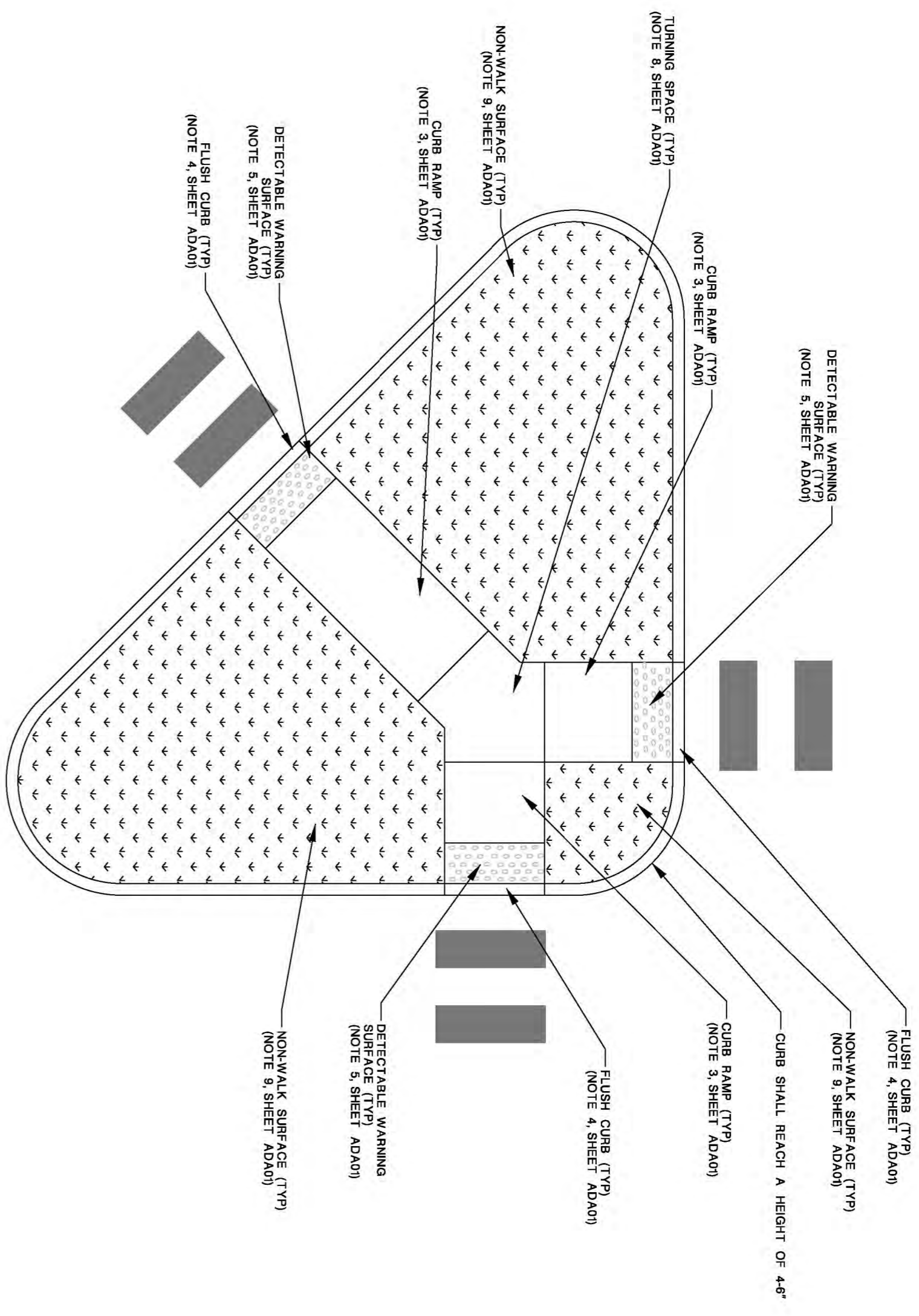

TYPE 4Q
CURB RAMP
ISLAND CURB RAMP

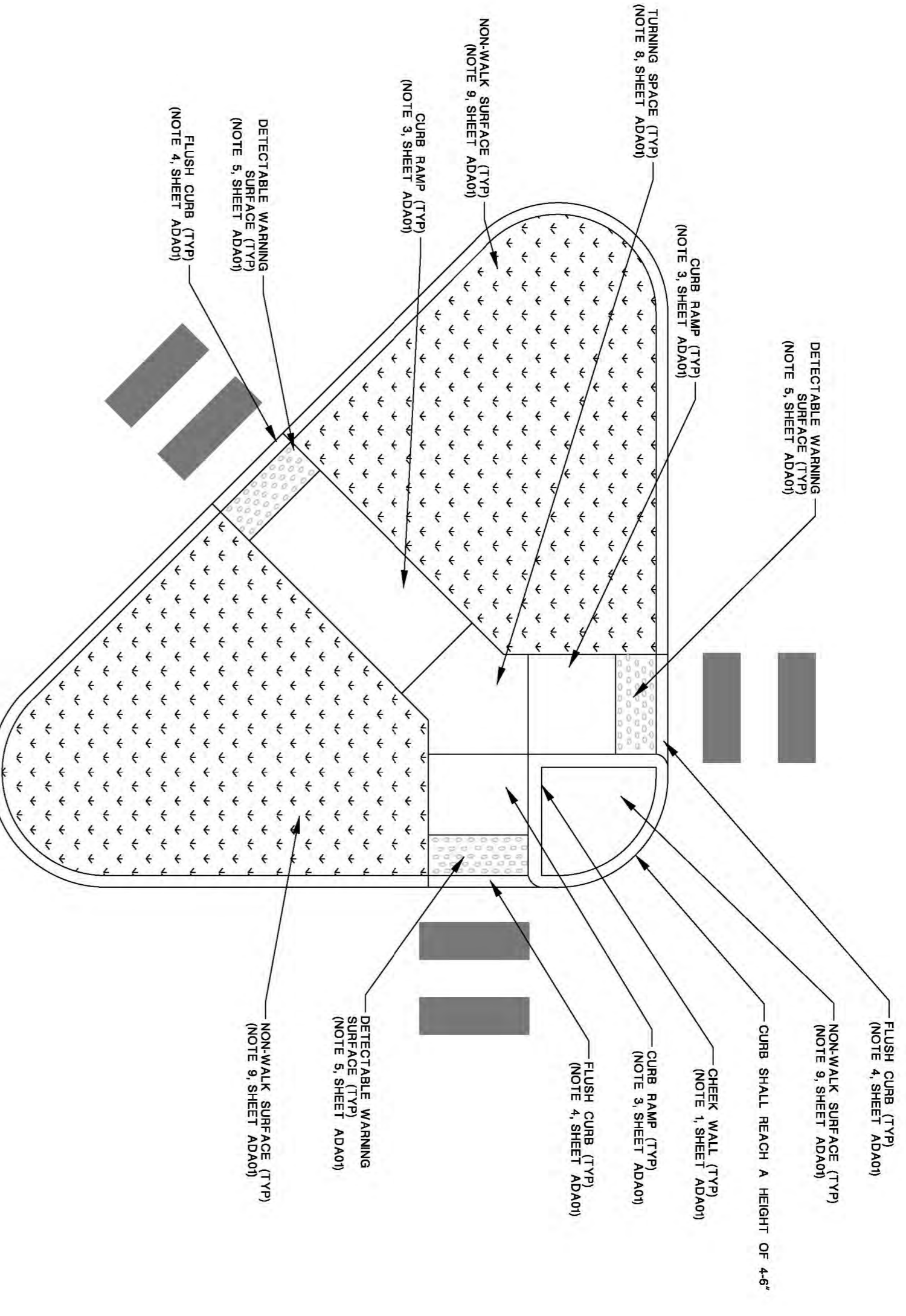

TYPE 4R
CURB RAMP
ISLAND CURB RAMP

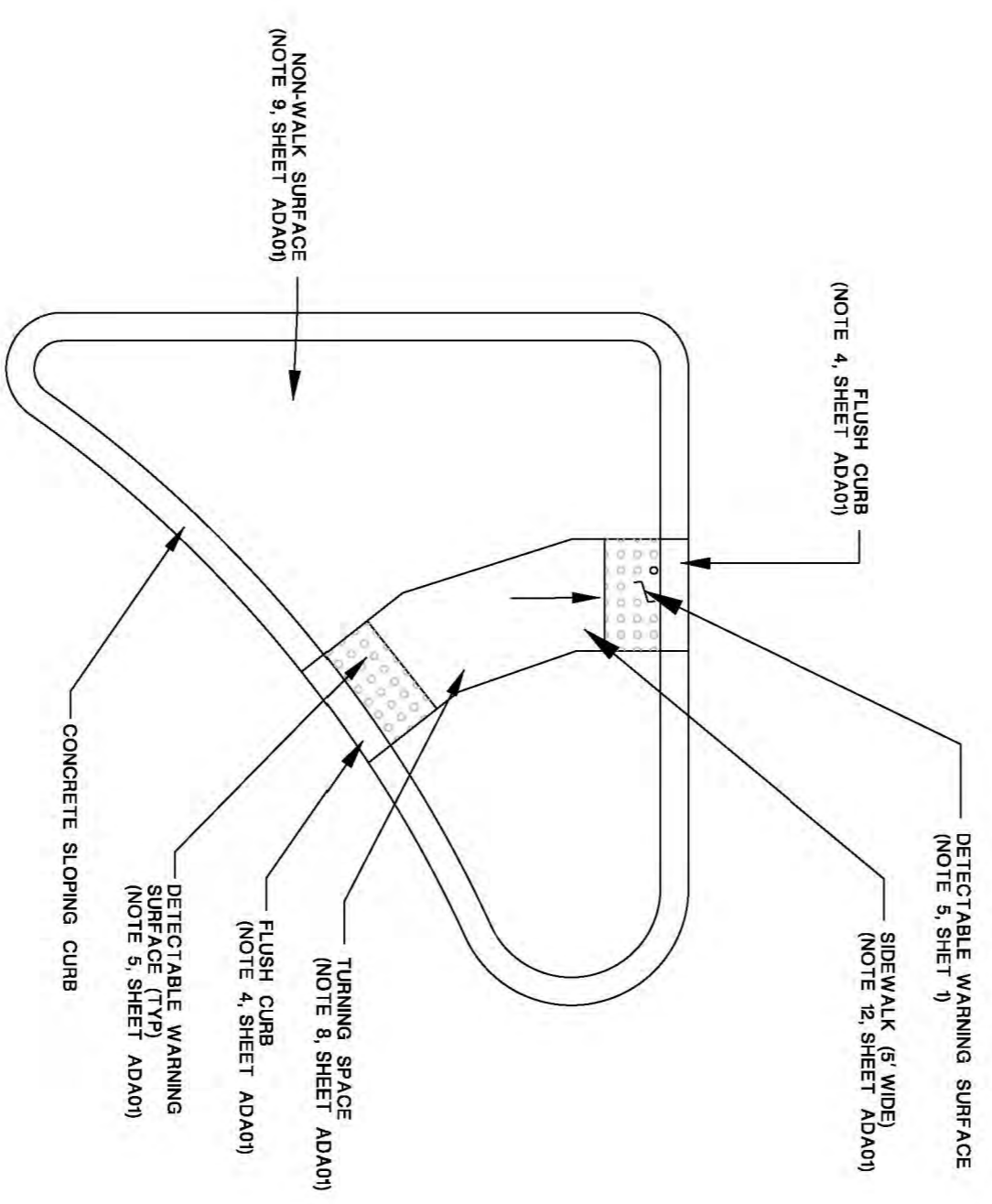

TYPE 4S
SMALL ISLAND

CURB RAMPS AND SIDEWALKS

TYPE 4

DATE		REVISION		DETAILS NO.	
OCEAN COUNTY					
ADA DETAILS & SPECIFICATIONS					
ADA CURB RAMP DETAILS					
DATE	BY	CHECKED	DATE	BY	PROJECT
JOHN N. ERNST COUNTY ENGINEER			SHEET 18 OF 23		

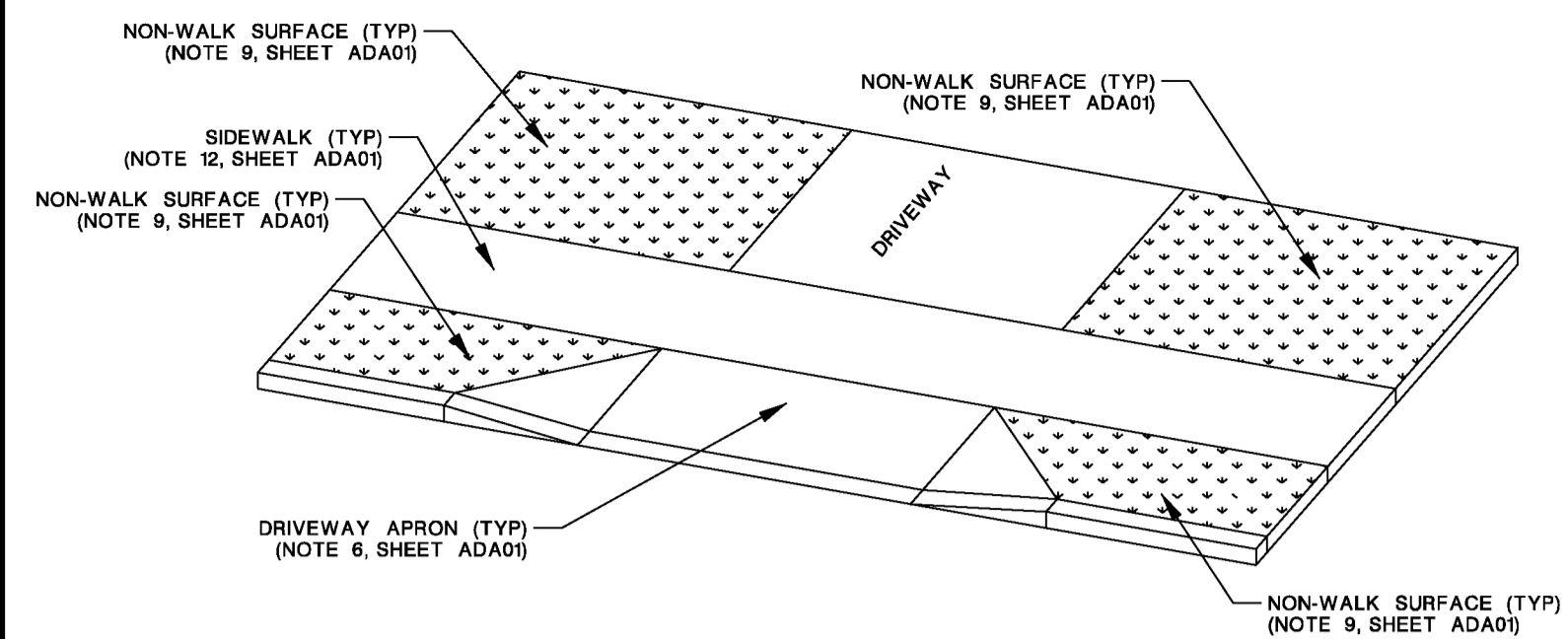

**TYPE 5A
DRIVEWAY APRON**

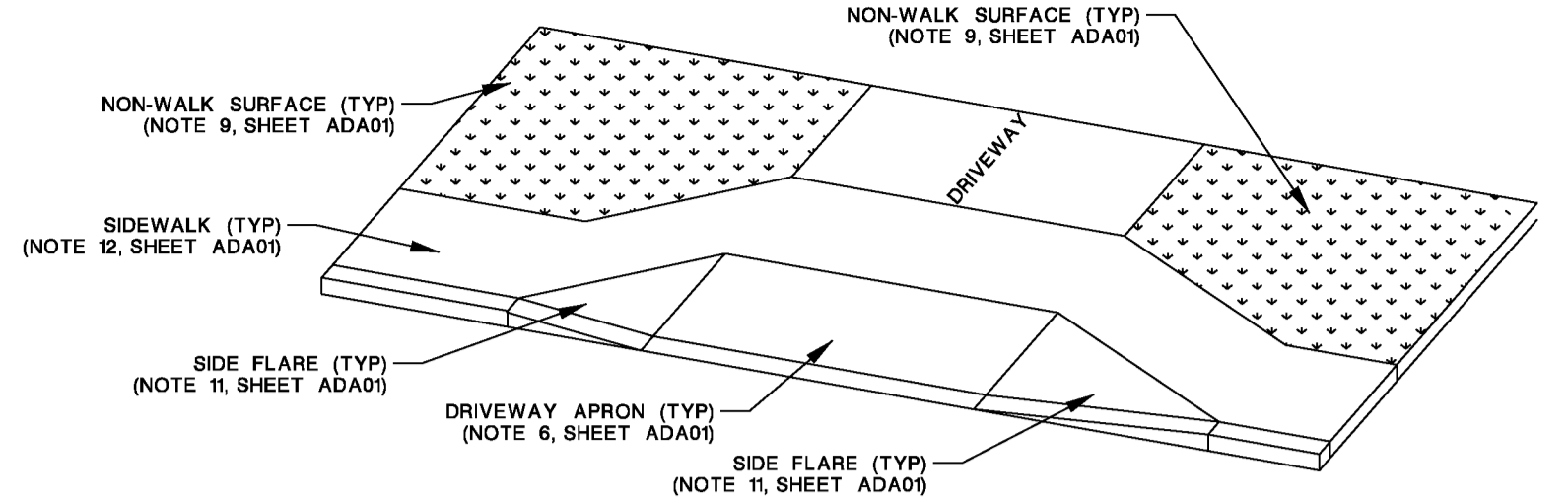

**TYPE 5D
DRIVEWAY APRON**

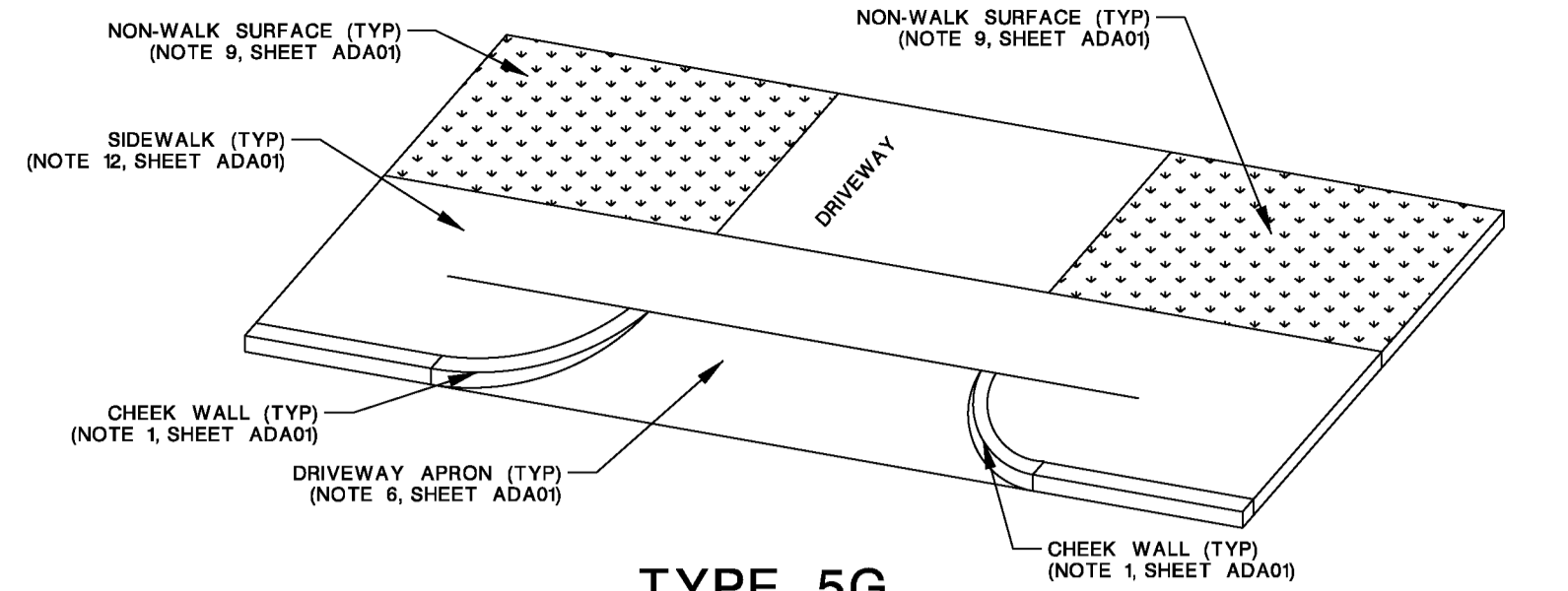

**TYPE 5G
DRIVEWAY APRON**

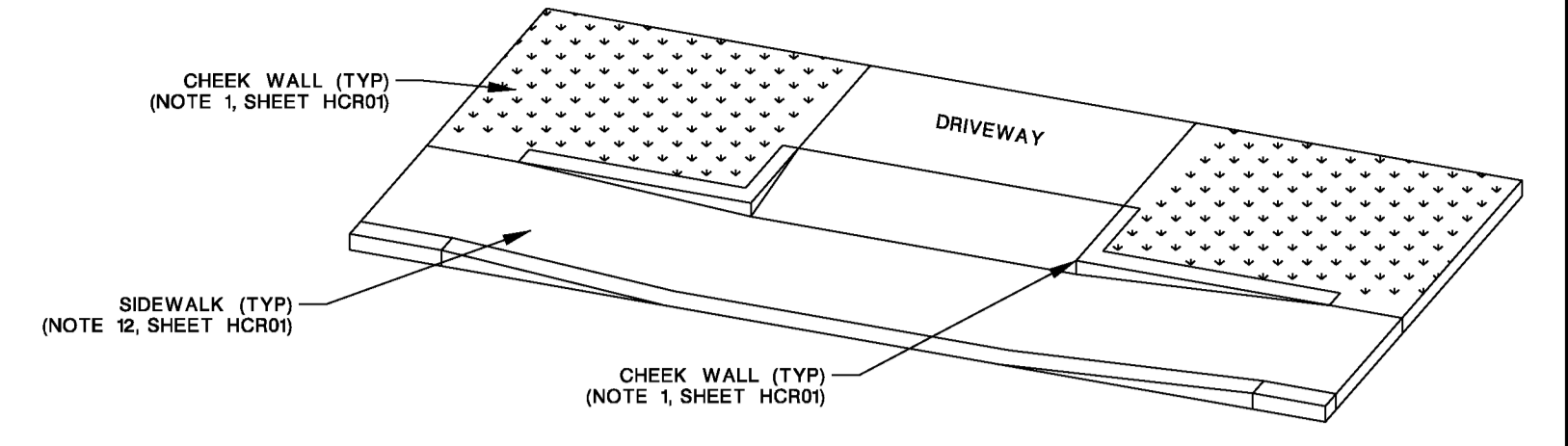

**TYPE 5B
DRIVEWAY APRON**

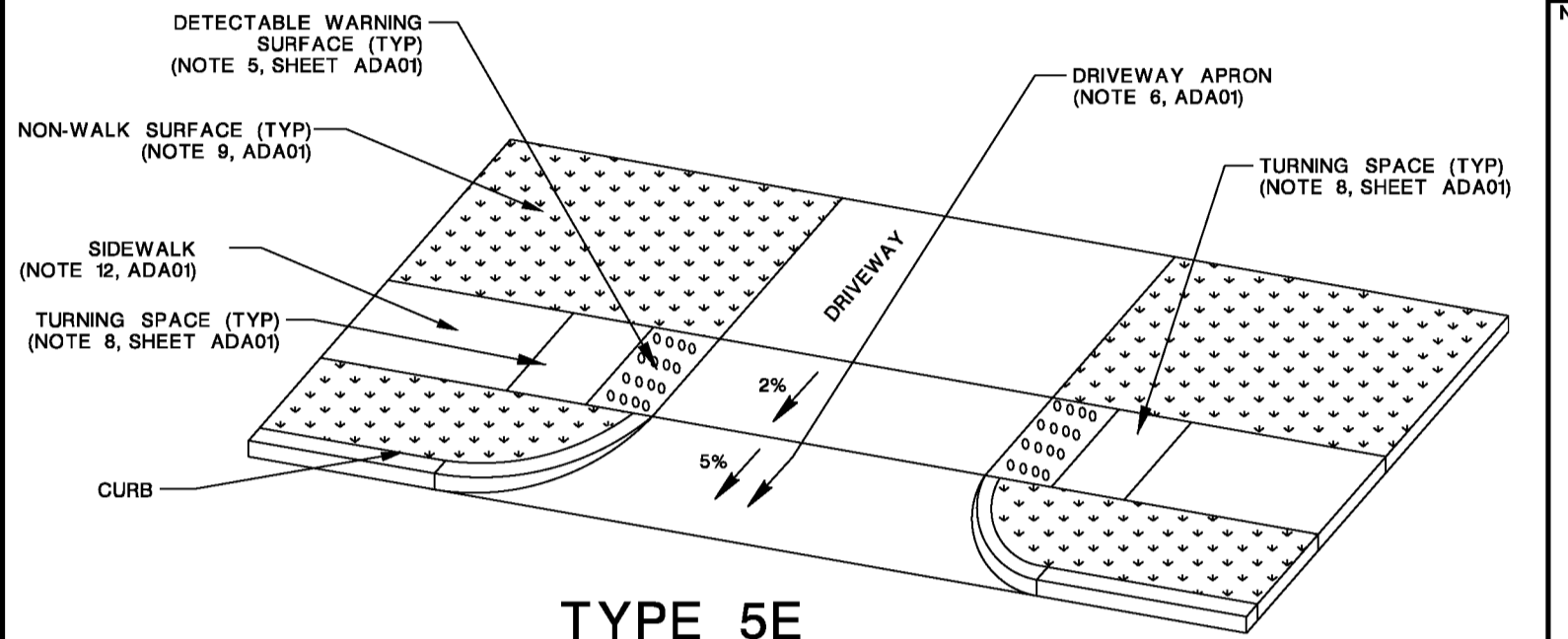

**TYPE 5E
DRIVEWAY APRON
FOR COMMERCIAL DRIVEWAY**

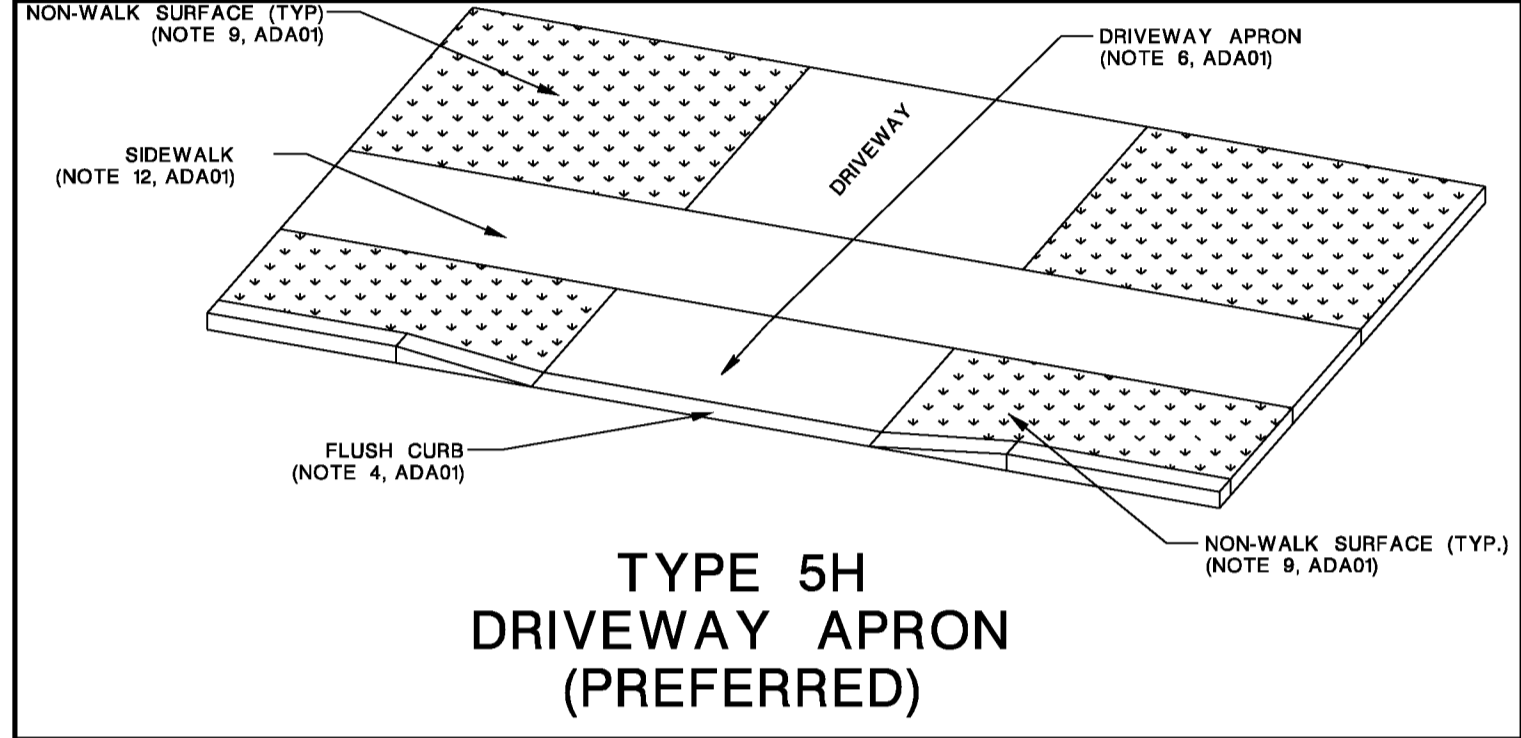

**TYPE 5H
DRIVEWAY APRON
(PREFERRED)**

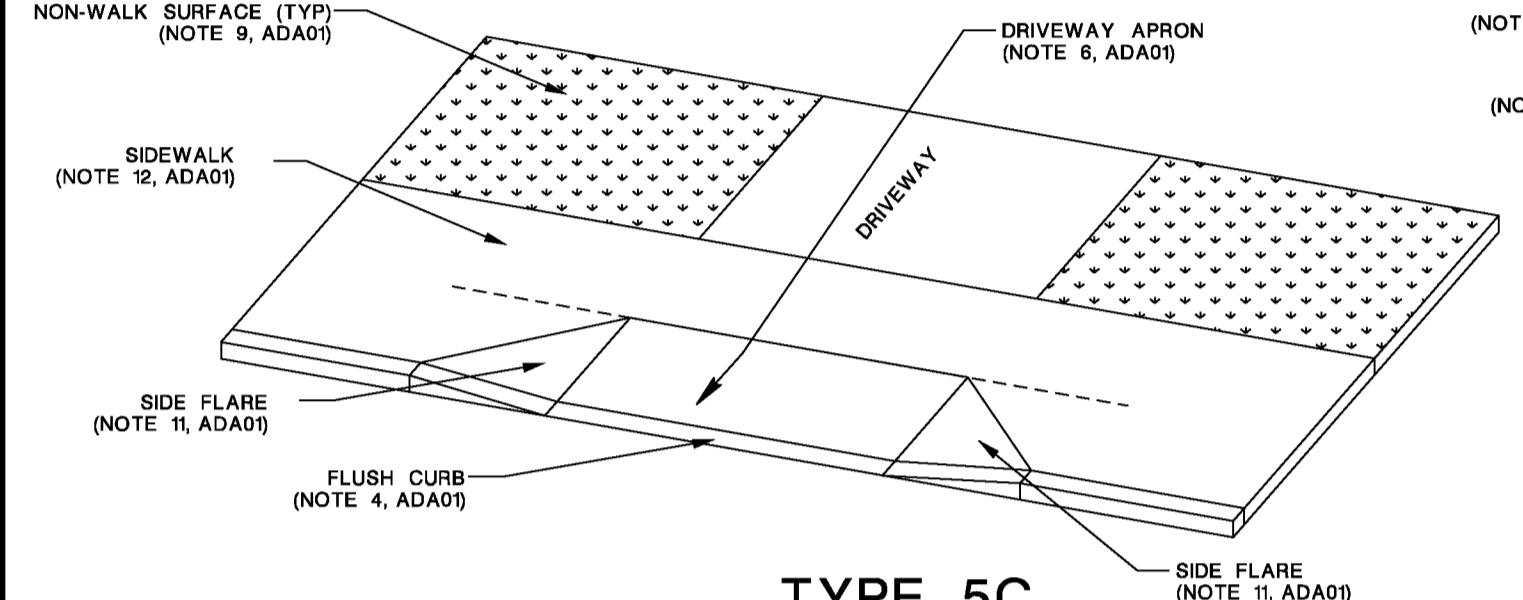

**TYPE 5C
DRIVEWAY APRON**

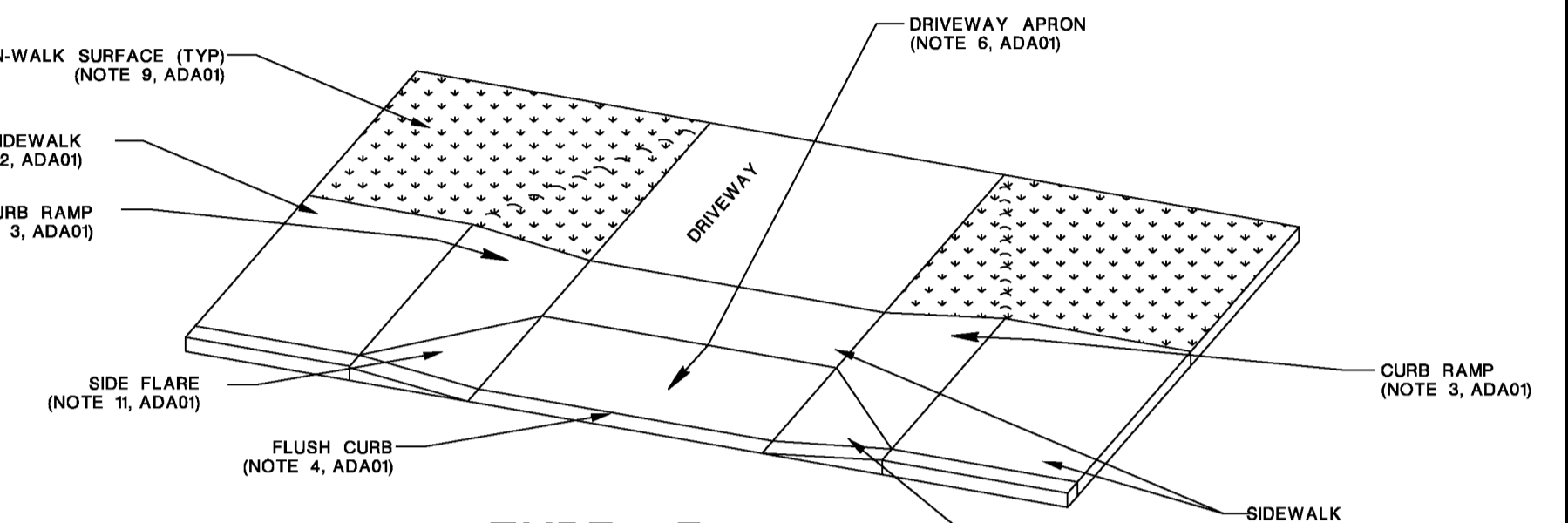

**TYPE 5F
DRIVEWAY APRON**

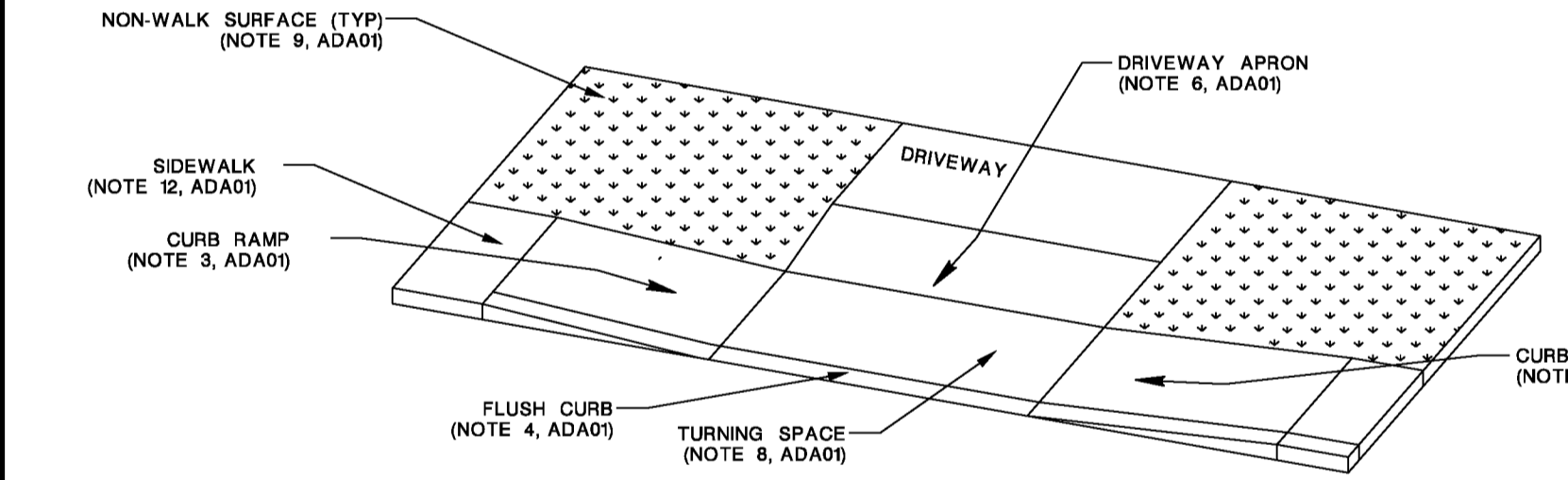

**TYPE 5I
DRIVEWAY APRON**

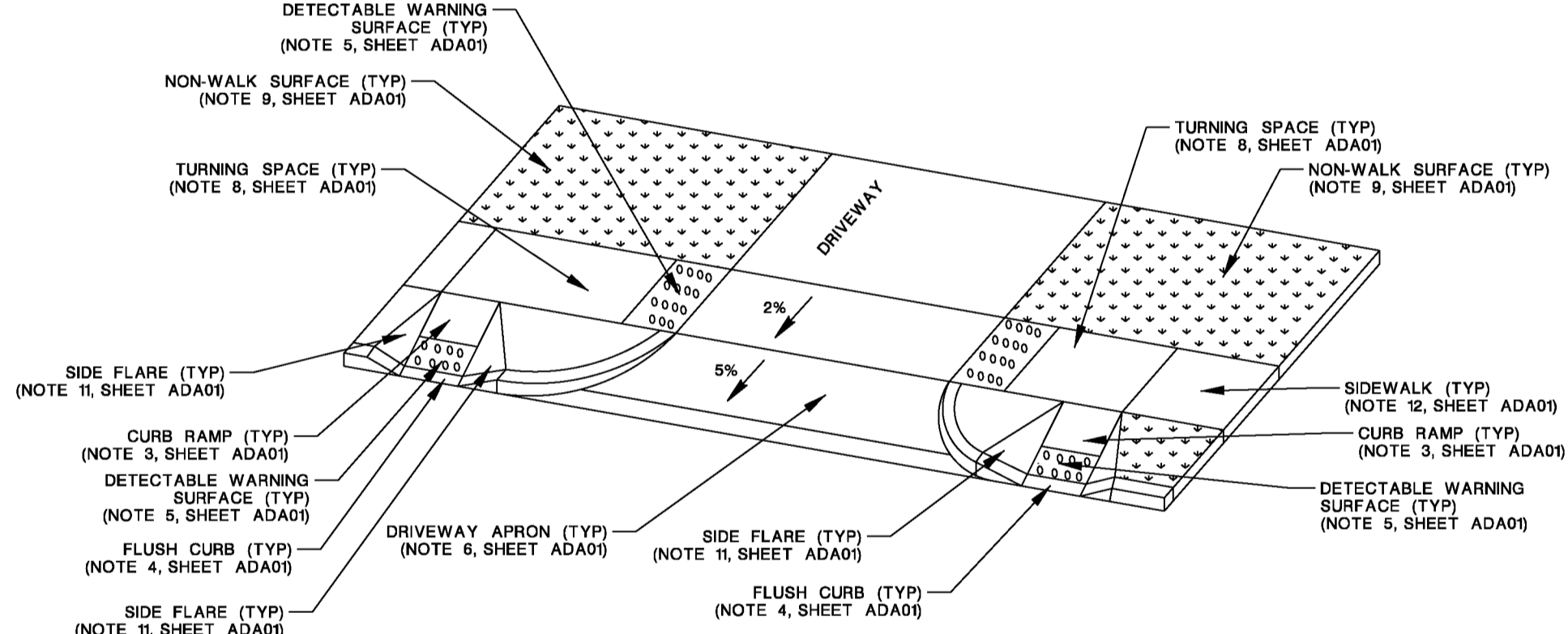

**TYPE 5J
DRIVEWAY APRON
FOR COMMERCIAL DRIVEWAY**

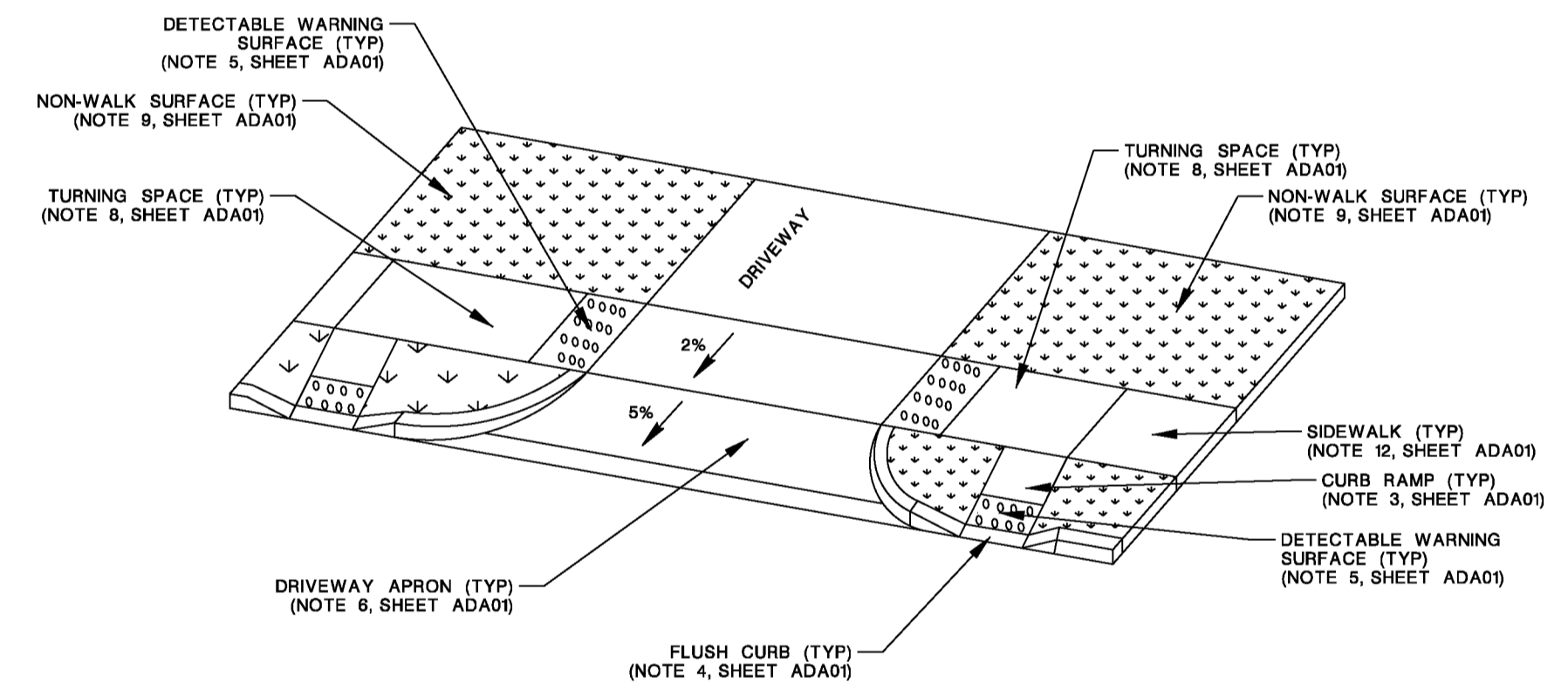

**TYPE 5K
DRIVEWAY APRON
FOR COMMERCIAL DRIVEWAY**

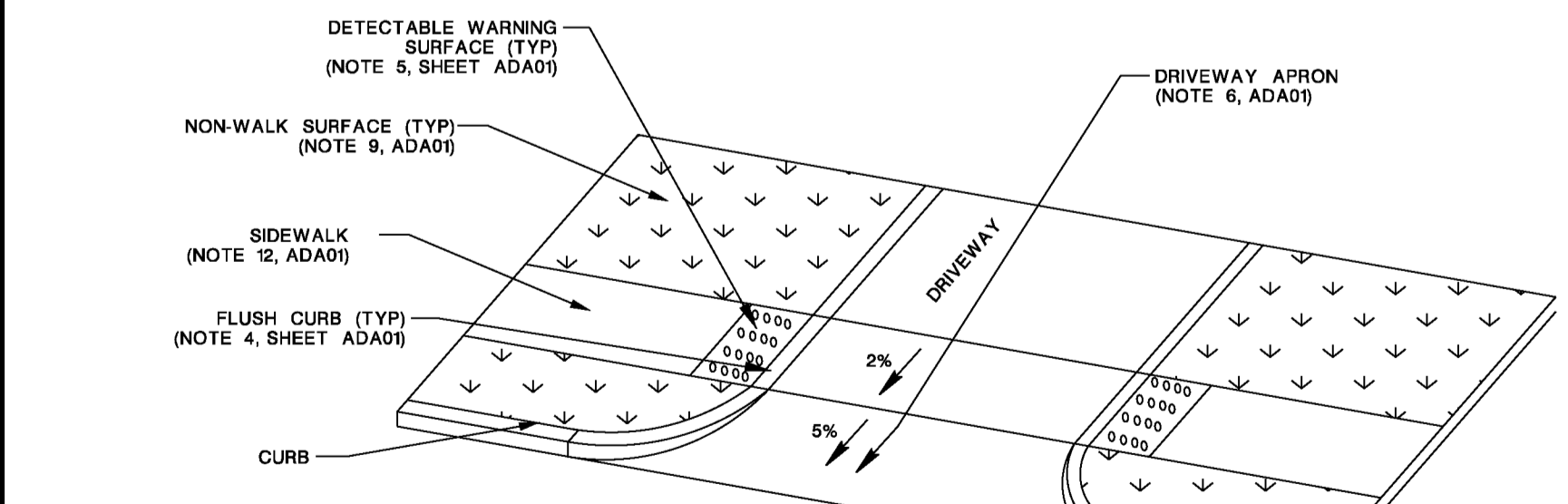

**TYPE 5L
DRIVEWAY APRON
FOR COMMERCIAL DRIVEWAY**

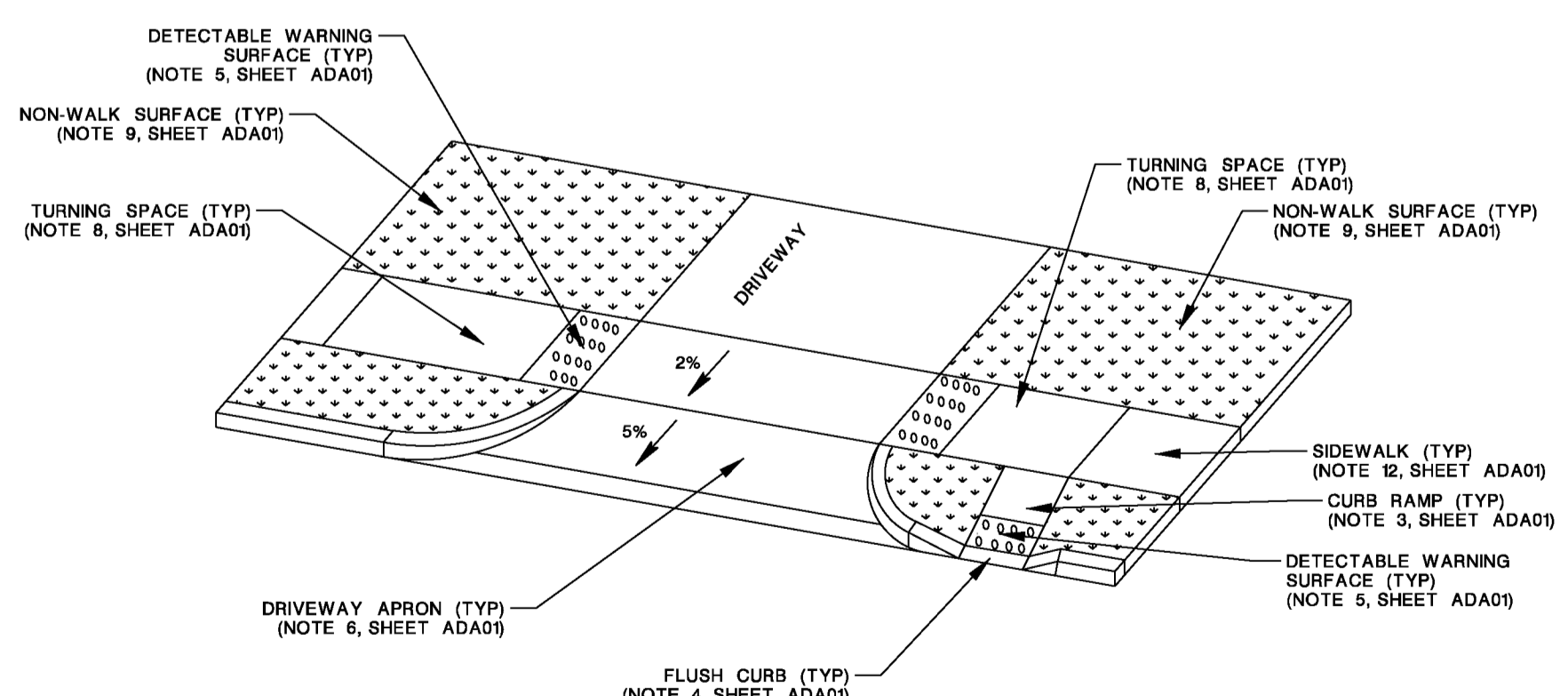

**TYPE 5K
DRIVEWAY APRON
FOR COMMERCIAL DRIVEWAY**

CURB RAMPS AND SIDEWALKS

TYPE 5

DATE	REVISIONS	BY	CHK.
 OCEAN COUNTY ADA DETAILS & SPECIFICATIONS ADA CURB RAMP DETAILS			
DATE	DESIGNED	...	CHECKED
SCALE	NTS	DRAWN	APPROVED
JOHN N. ERNST COUNTY ENGINEER			F.S.S. SHEET 14 OF 23

© 2010 Ocean County, NJ. All rights reserved. Ocean County, NJ.

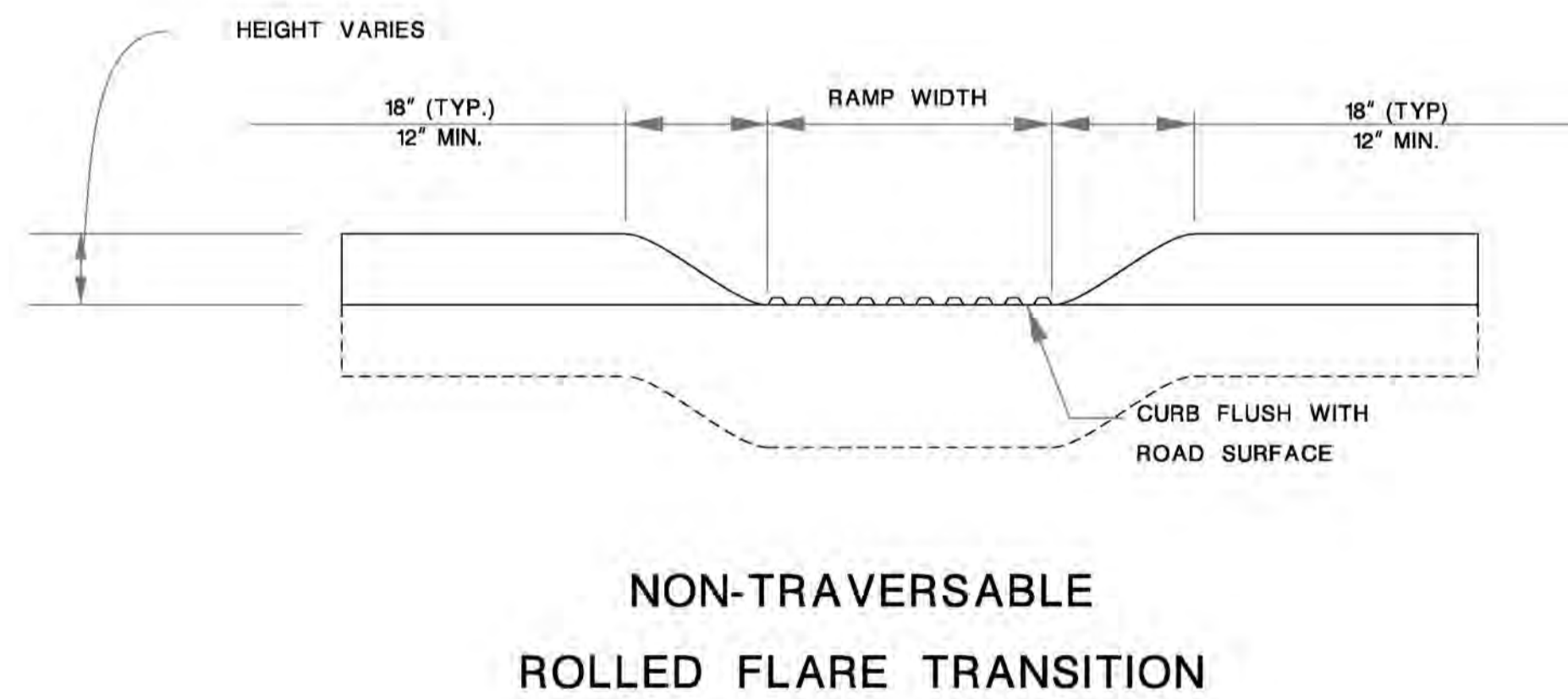
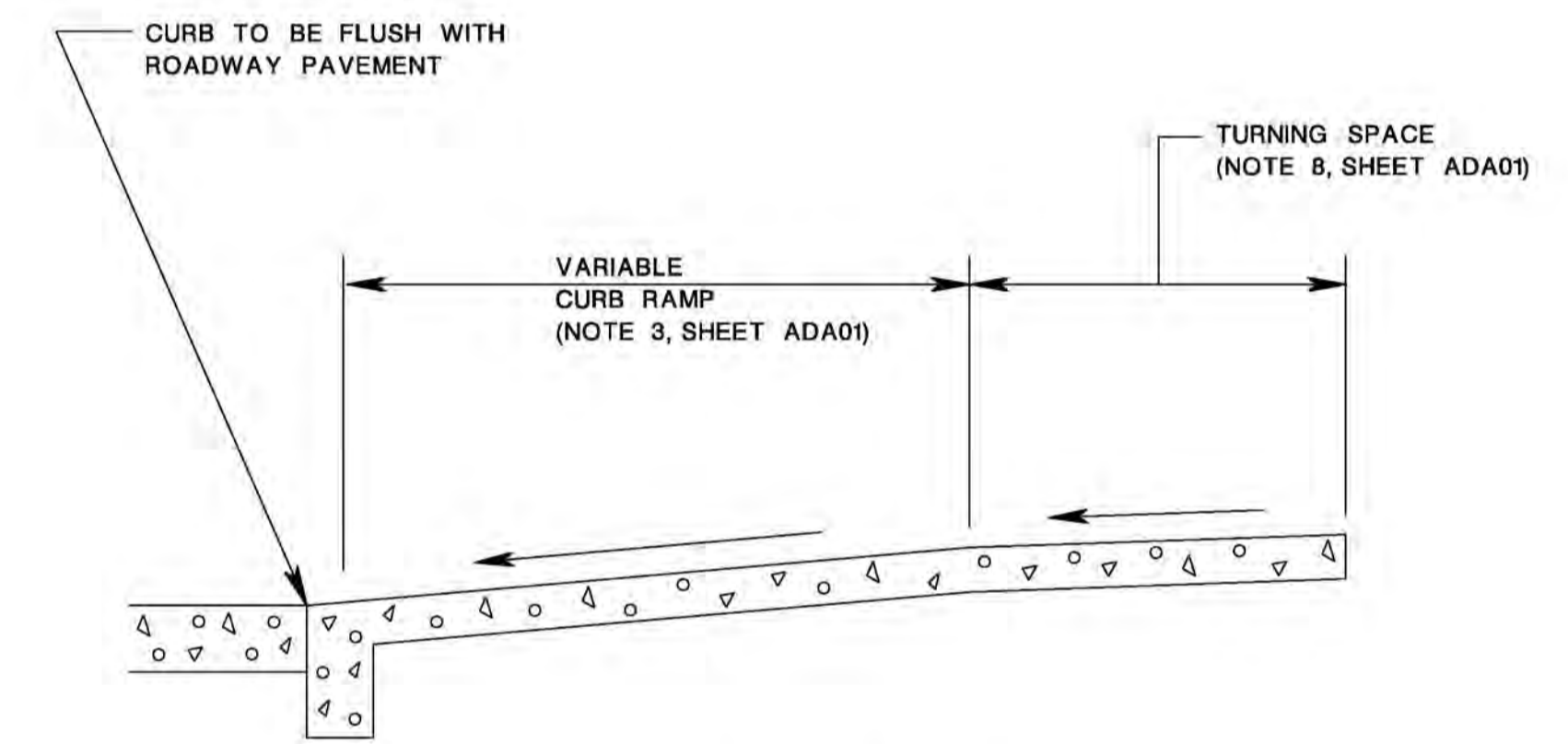
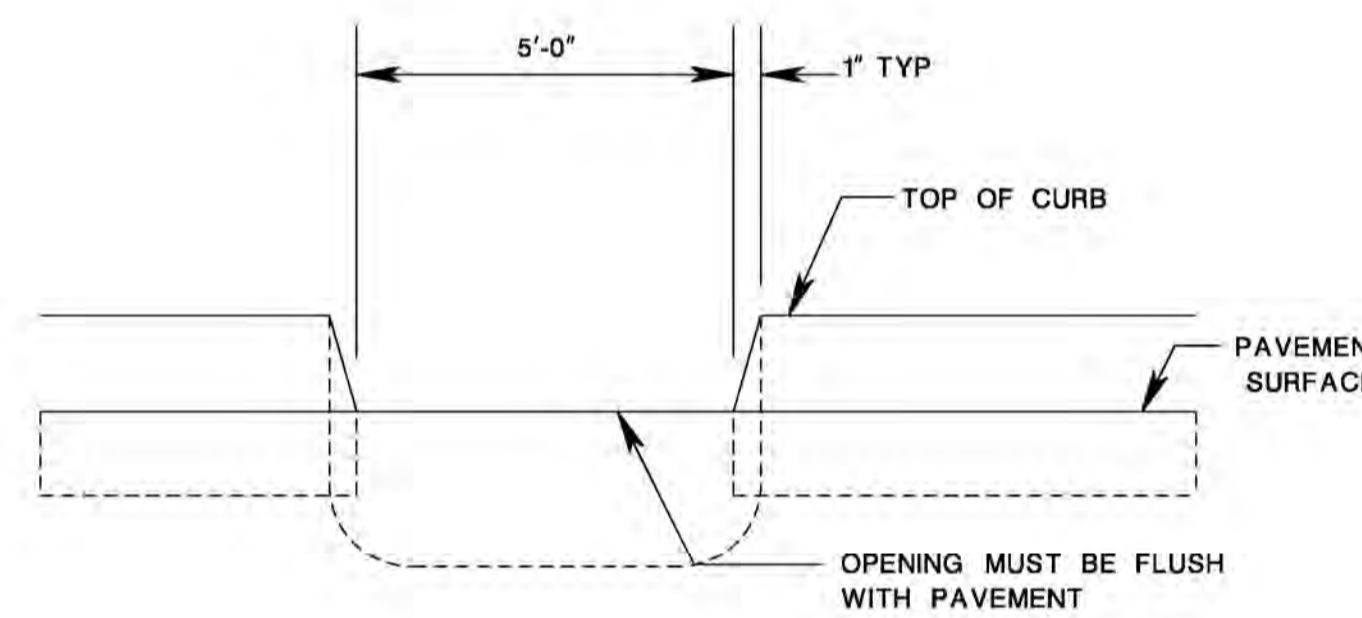
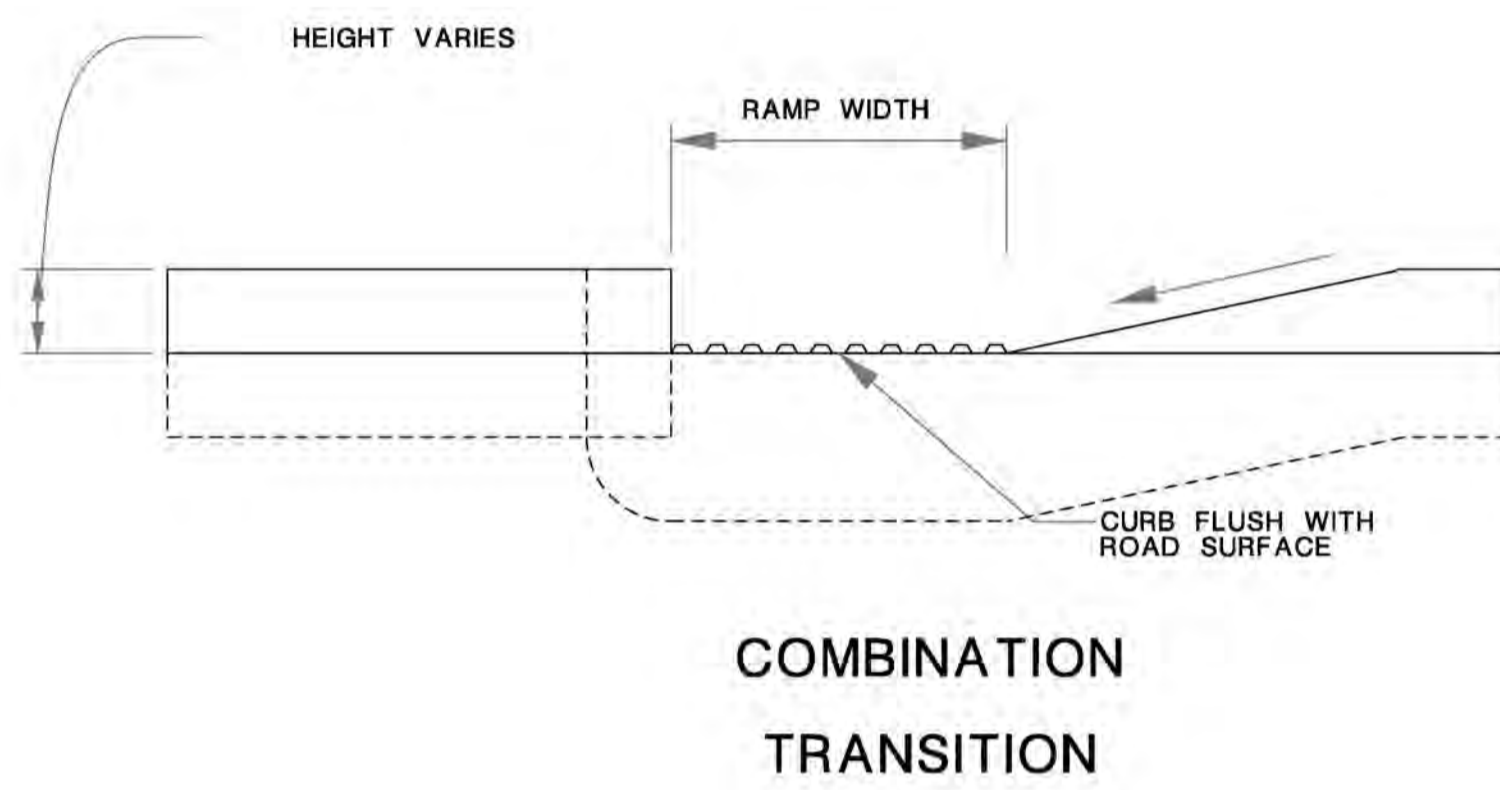
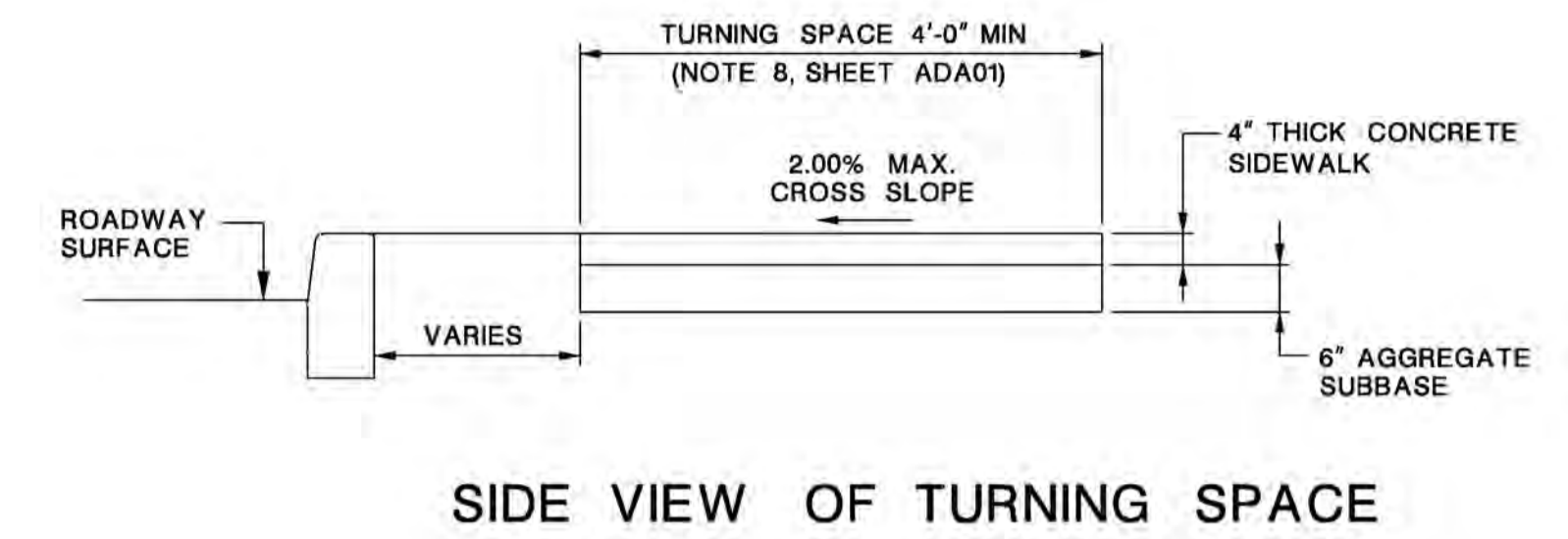
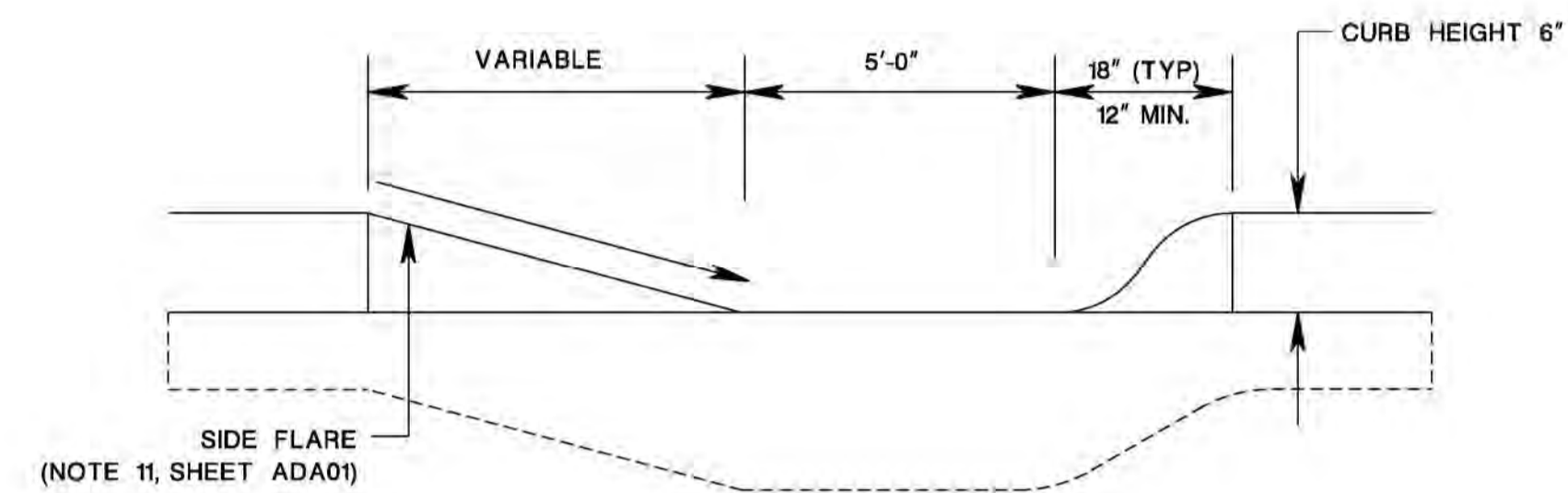
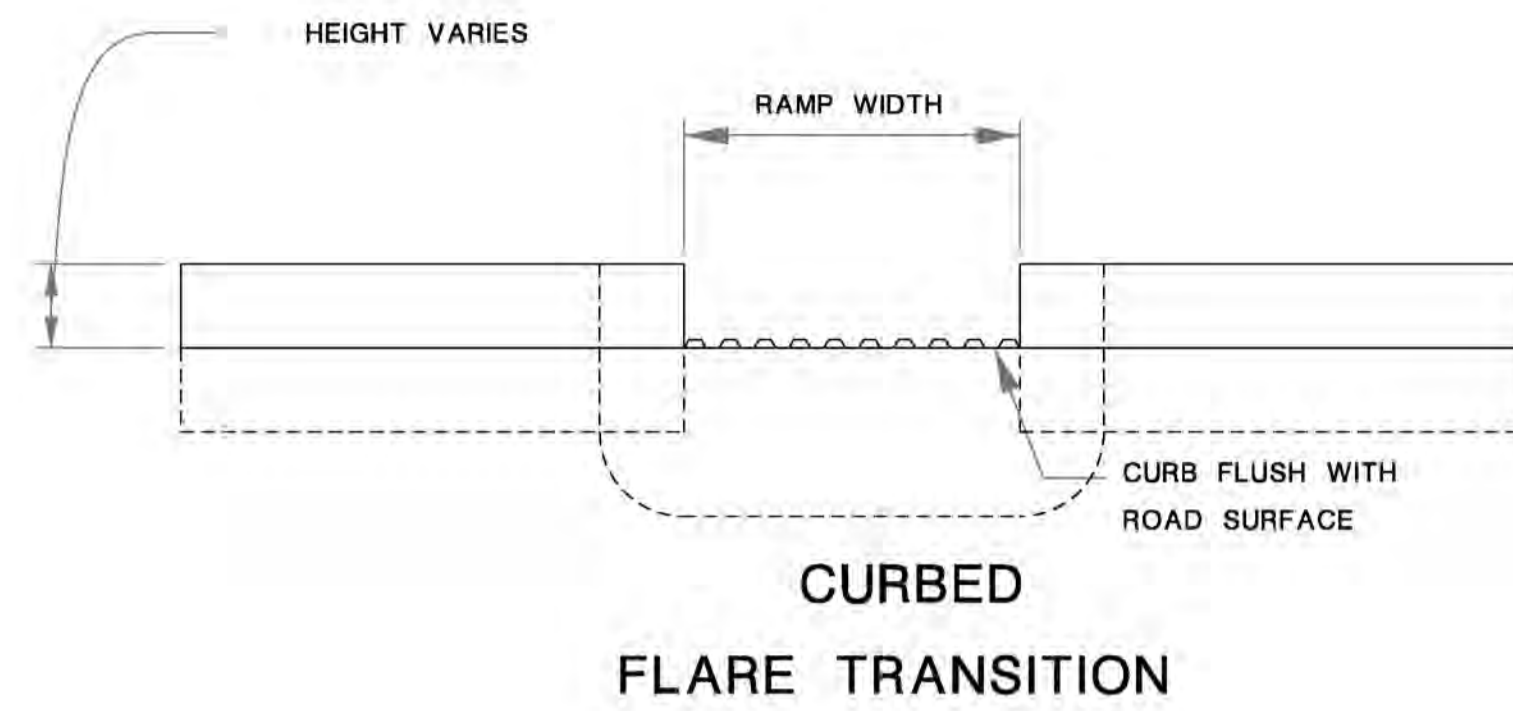

TYPICAL ELEVATIONS FOR FLUSH CURBS

**CURB RAMPS AND SIDEWALKS
TYPICAL SECTIONS**

DATE	REVISIONS	BY	JOB
DETAILS FOR			
OCEAN COUNTY			
ADA DETAILS & SPECIFICATIONS			
ADA CURB RAMP DETAILS			
DATE	DRAWN	CHECKED	DATE
SCALE	N.T.S.	APPROVED	F.S.B.
FILE NO. 194		SHEET 16 OF 28	



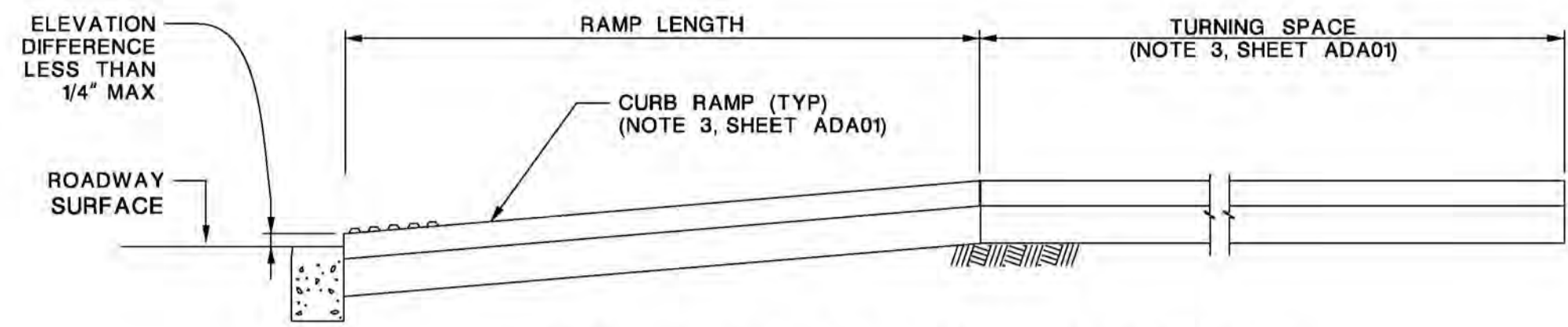

**EXISTING RAMP SECTION
(VERTICAL DROP AT RAMP)**

RECOMMENDED CORRECTION:
RECONSTRUCT THE ENTIRE (OR PORTIONS OF) RAMP, TURNING SPACES AND FLARES WHERE APPLICABLE
(SEE RAMP RECONSTRUCTION DETAIL ON SHEET ADA019)

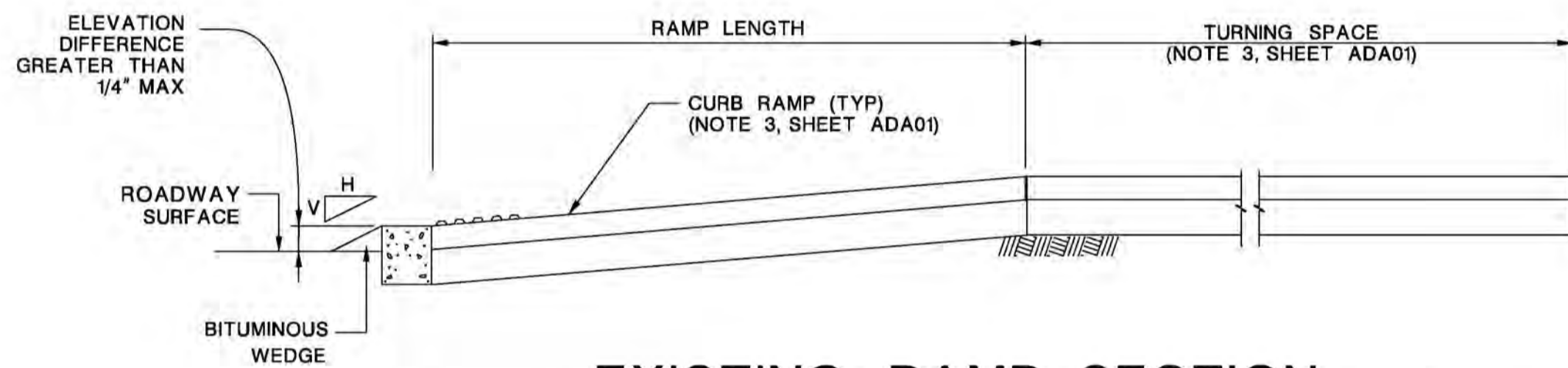

**EXISTING RAMP SECTION
(VERTICAL DROP AT ROAD SURFACE)**

RECOMMENDED CORRECTION:
ELEVATION DIFFERENCE GREATER THAN 1/4" AND LESS THAN OR EQUAL TO 1/2":
PLACE BITUMINOUS MATERIAL AT FACE OF CURB TO BEVEL TRANSITION
AT A 2:1 (HORZ:VERT) RATE AS SHOWN.

ELEVATION DIFFERENCE GREATER THAN 1/2", USE 8.00% MAX:
PLACE BITUMINOUS MATERIAL AT FACE OF CURB TO BEVEL TRANSITION
AT A SLOPE EQUAL TO THE RAMP SLOPE OR TURNING SPACE SLOPE.

GRINDING THE CURB TO PROVIDE A MAXIMUM SLOPE OF 8.00% IS ACCEPTABLE &
FINISHED SURFACE MUST NOT HAVE ELEVATION DIFFERENCES GREATER THAN 1/4".

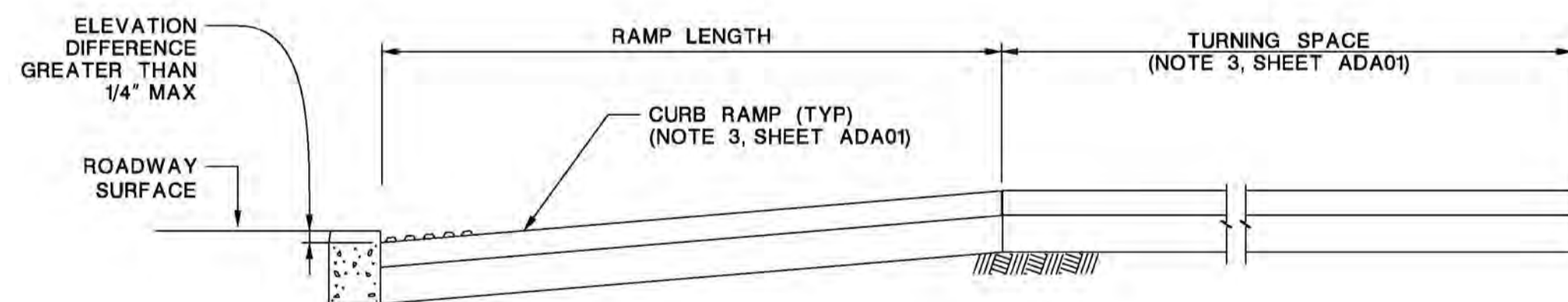

**EXISTING RAMP SECTION
(RAMP SETTLEMENT)**

RECOMMENDED CORRECTION:
RECONSTRUCT THE ENTIRE (OR PORTIONS OF) RAMP, TURNING SPACES AND FLARES WHERE APPLICABLE
(SEE RAMP RECONSTRUCTION DETAIL ON SHEET ADA019)

ALTERATION DETAILS

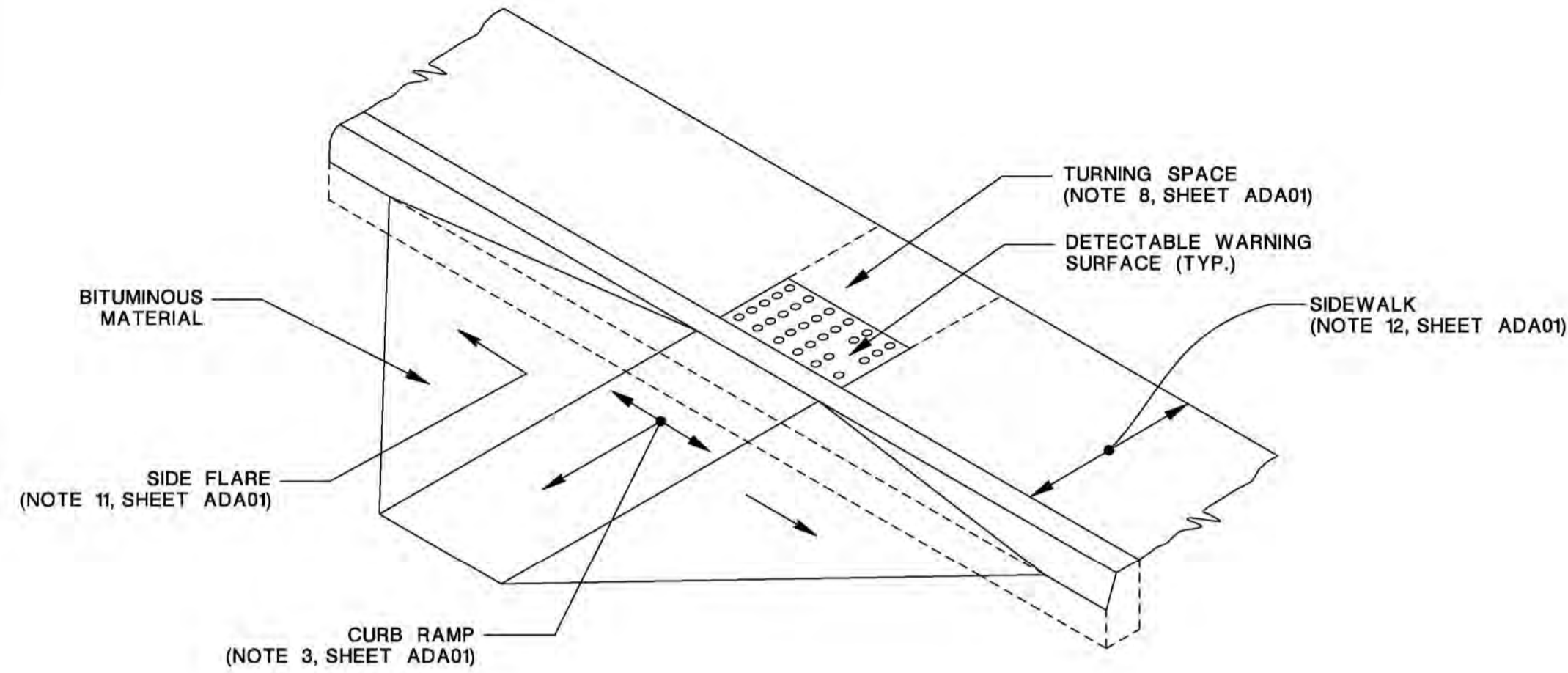

NOTES: DO NOT USE TYPE 1J CURB RAMPS IN VEHICULAR TRAFFIC LANES, PARKING SPACES, OR ACCESS AISLES.
CONSTRUCT TYPE 1J BUILT-UP CURB RAMP OF BITUMINOUS MATERIAL AS INDICATED, INCLUDING SURFACE PREPARATION AND TACK COAT, AS REQUIRED.

**(BUILT-UP, FOR ALTERATIONS ONLY)
OCEAN COUNTY ENGINEERING DEPARTMENT
APPROVAL REQUIRED**

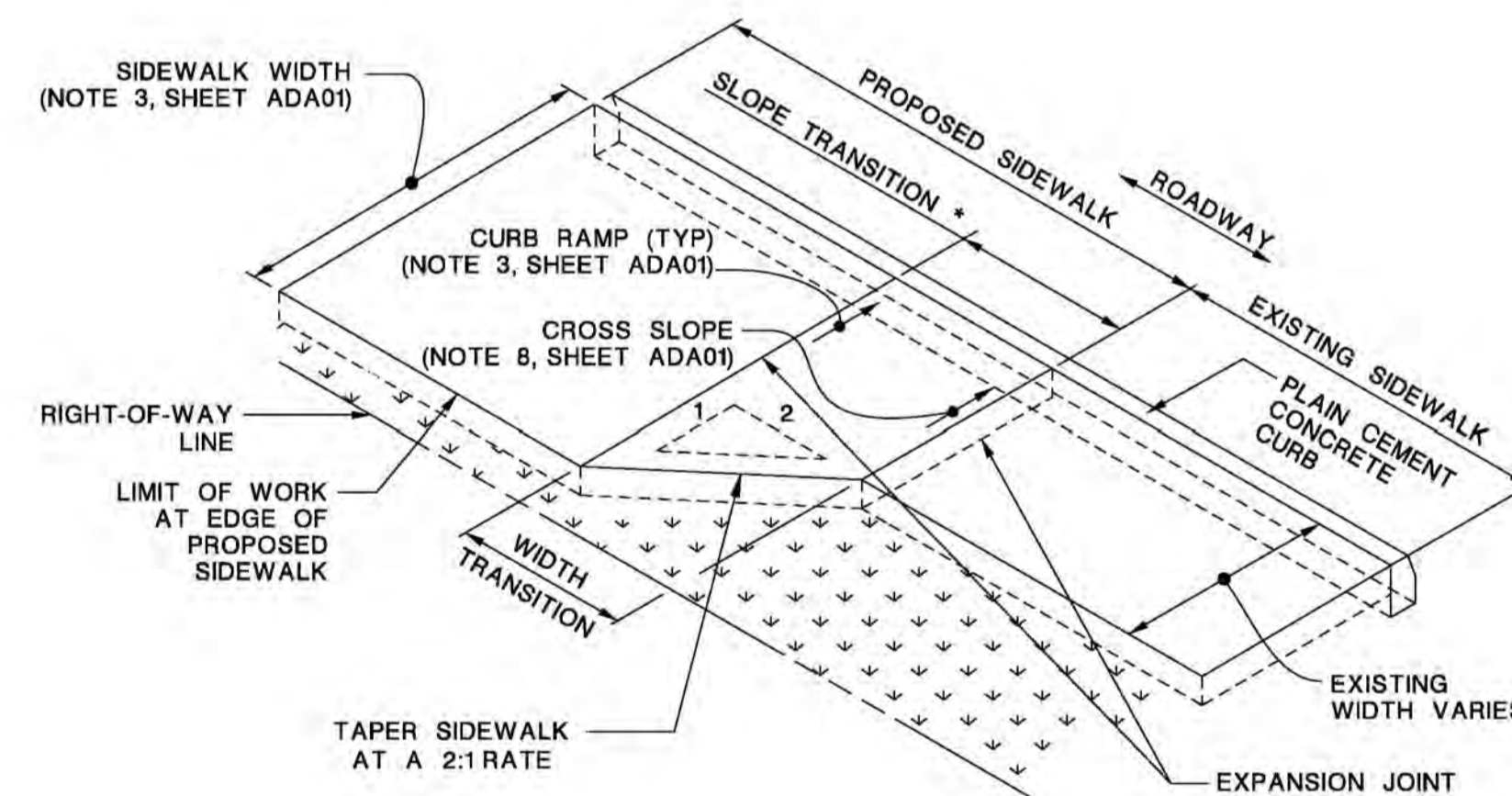

**TRANSITION TO EXISTING
SIDEWALK DETAIL**

* MINIMUM SLOPE TRANSITION LENGTH BASED ON THE DIFFERENCE OF PROPOSED SIDEWALK CROSS SLOPE AND EXISTING SIDEWALK CROSS SLOPE AT THE LOCATION OF TIE IN. THIS MINIMUM LENGTH TO BE DETERMINED BY THE FOLLOWING FORMULA:
 $\Delta \% \text{ SLOPE} \times 0.5'$

THE MINIMUM WIDTH TRANSITION SHALL BE CALCULATED USING THE FOLLOWING FORMULA:
 $\text{CHANGE IN WIDTH} \times (2)$

DEPENDING ON WHICH IS LONGEST, EITHER THE SLOPE TRANSITION OR WIDTH TRANSITION WILL CONTROL THE LENGTH OF SIDEWALK TRANSITION.

TRANSITION AREAS SERVE AS TEMPORARY CONNECTIONS OF THE PEDESTRIAN ACCESS ROUTE. FUTURE IMPROVEMENTS TO THE REMAINING PORTION OF EXISTING SIDEWALK SHALL INCLUDE REMOVING THE TRANSITION AREA AND CONSTRUCTING A FULLY COMPLIANT SIDEWALK.

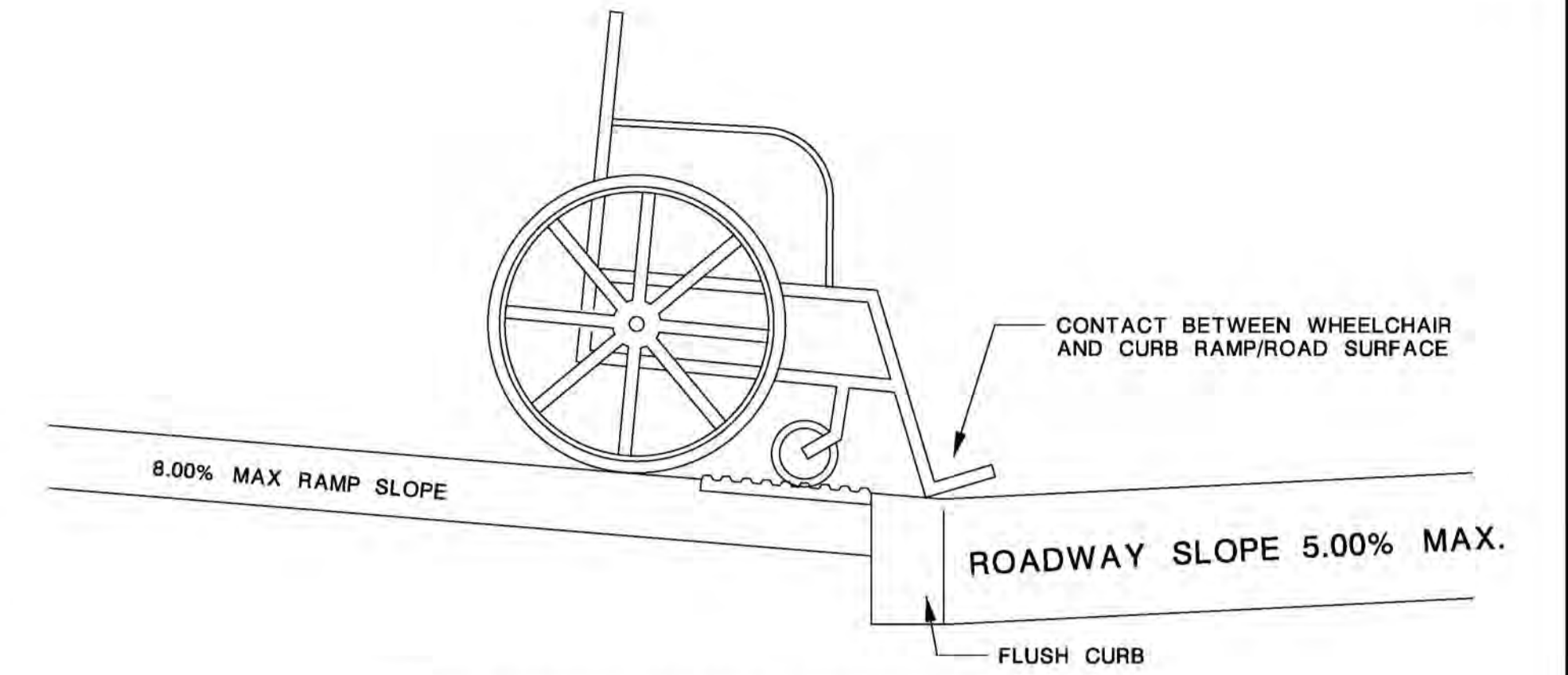

ALGEBRAIC DIFFERENCES BETWEEN ROADWAY SLOPE AND CURB RAMP SLOPE GREATER THAN 11.00% NOT PERMITTED.

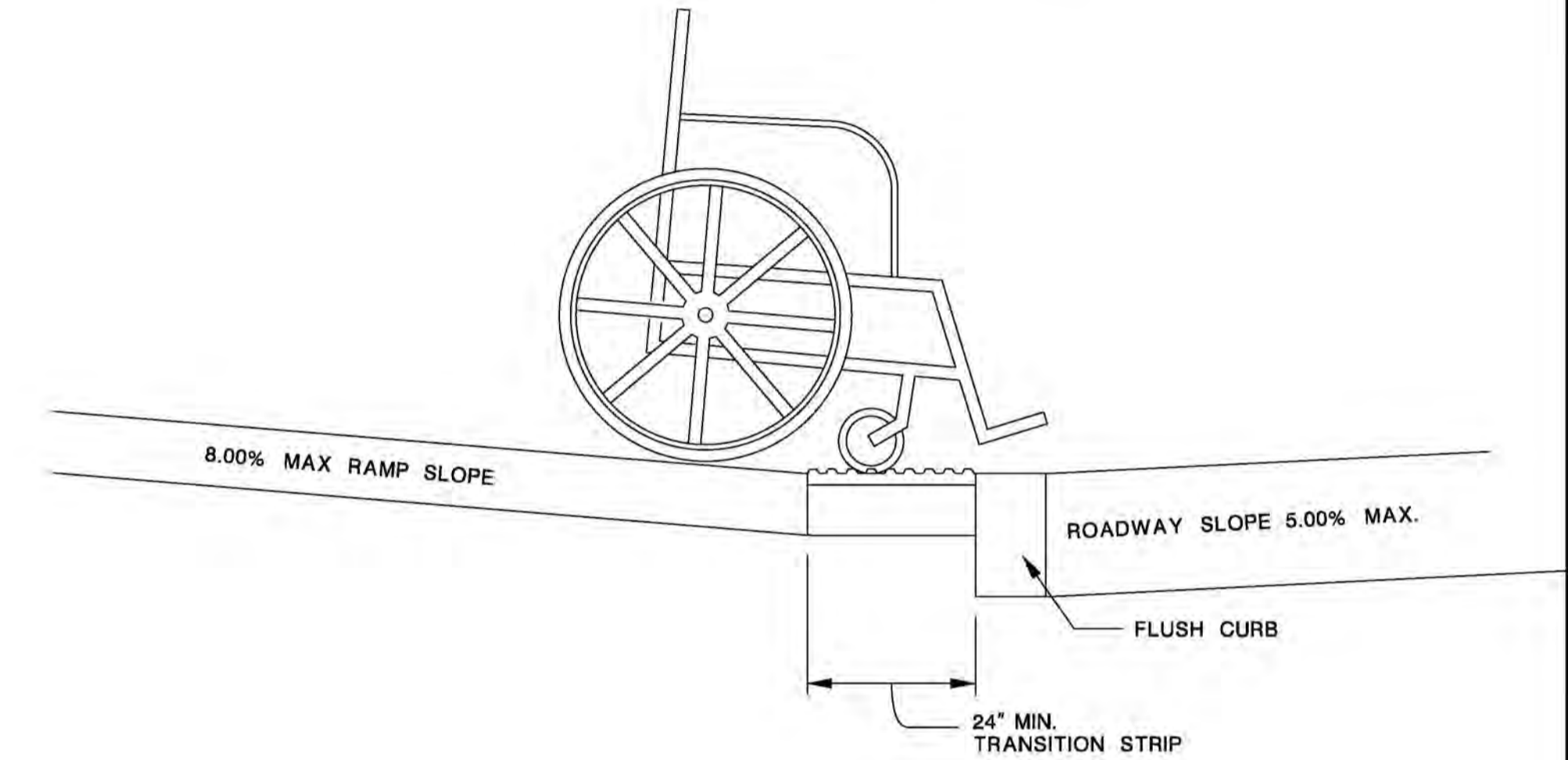

PROVIDE A 24" MIN. TRANSITION STRIP IF ALGEBRAIC DIFFERENCES BETWEEN ROADWAY SLOPE AND CURB RAMP SLOPE ARE GREATER THAN 11.00%.
TRANSITION STRIP SLOPE NOT TO EXCEED 2.00%

**CHANGE OF GRADE
LIMITATIONS**

CURB RAMPS AND SIDEWALKS

**RAMP & SIDEWALK
SPECIFICATIONS**

DATE	REVISIONS	BY	CHK.
DETAILS FOR			
OCEAN COUNTY			
ADA DETAILS & SPECIFICATIONS			
ADA CURB RAMP DETAILS			
DATE	DRAWN	CHECKED	DATE
SCALE	N.T.S.	APPROVED	F.S.B.
 JOHN N. ERNST COUNTY ENGINEER			SHEET 17 OF 23

EXAMPLES OF DETECTABLE WARNING SURFACE PLACEMENT FOR CURB RAMPS PLACED IN THE RADIUS

PROVIDE A LEVEL TRIANGULAR TURNING SPACE WHEN DIRECTIONAL RAMPS ARE INSTALLED ON A CURB RETURN TO TRANSITION THE GRADE BREAK.

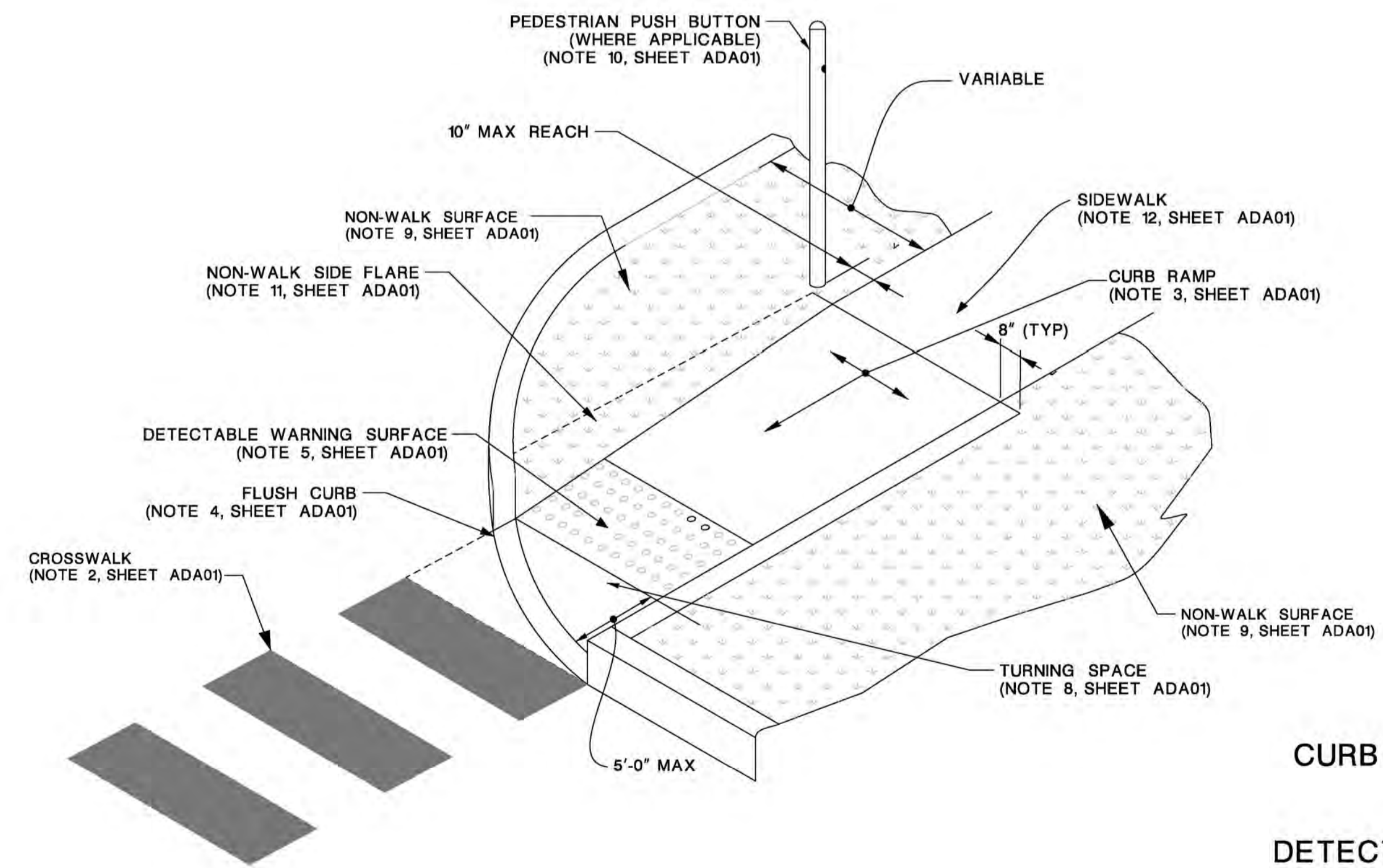
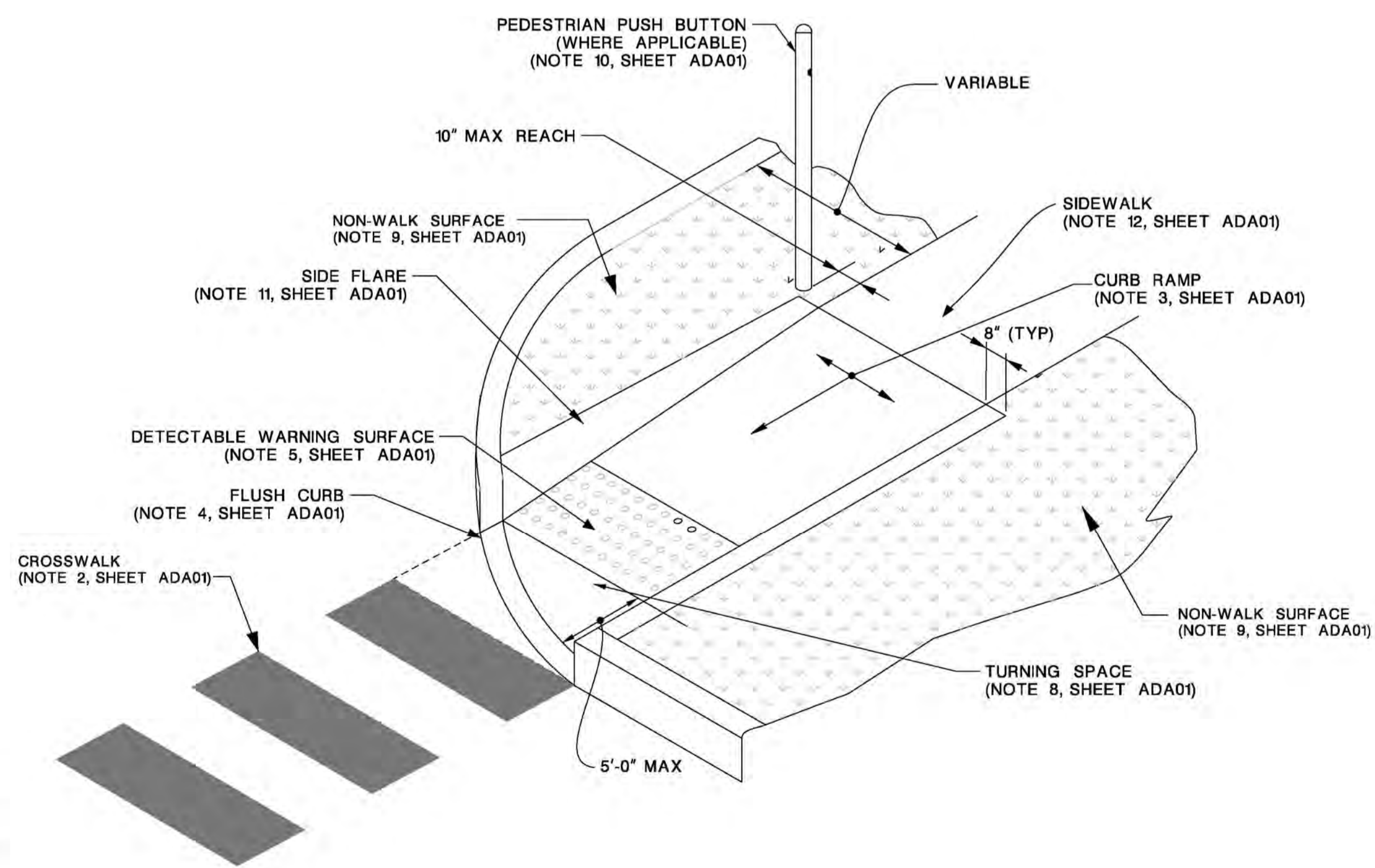
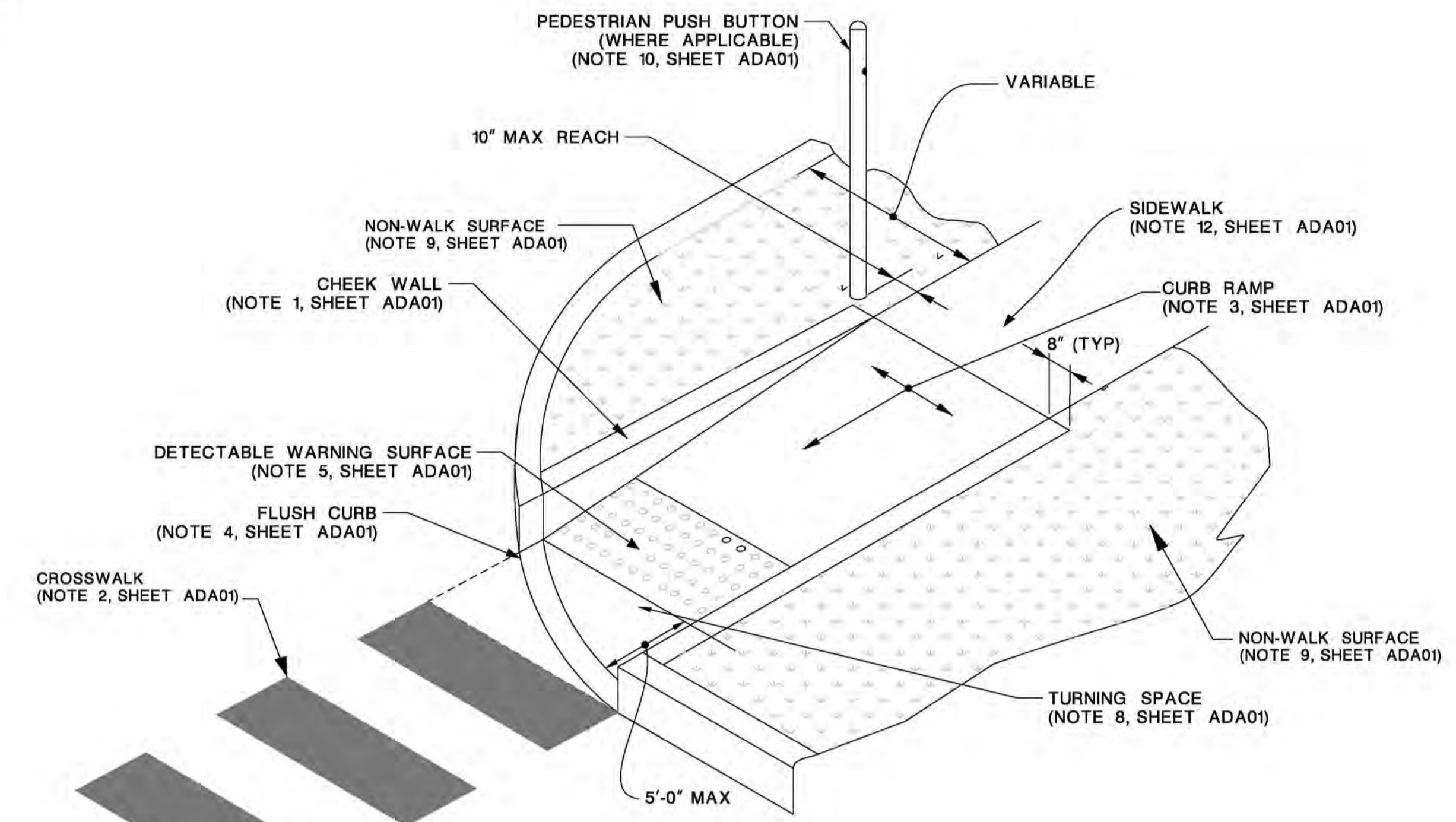
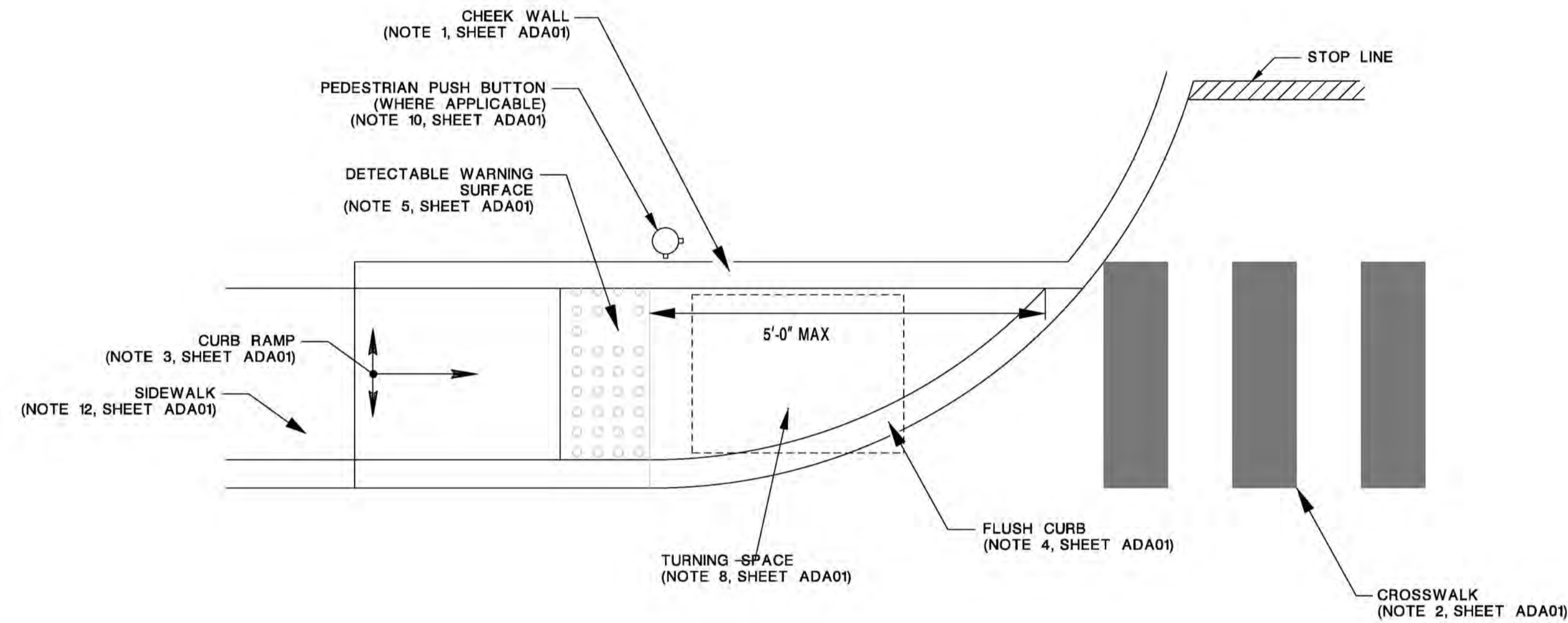

CURB RAMPS AND SIDEWALKS

DETECTABLE WARNING SURFACE SPECIFICATIONS

DATE	REVISIONS	BY	CHK.
DETAILS FOR			
OCEAN COUNTY			
ADA DETAILS & SPECIFICATIONS			
ADA CURB RAMP DETAILS			
DATE	BY	DESIGNED	CHECKED
SCALE	N.T.S.	DRAWN	APPROVED
			F.S.B.
FILE NO. 1991			SHEET 18 OF 23

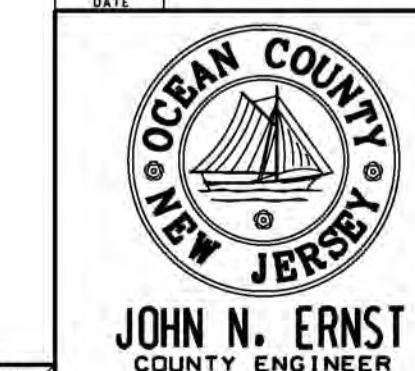
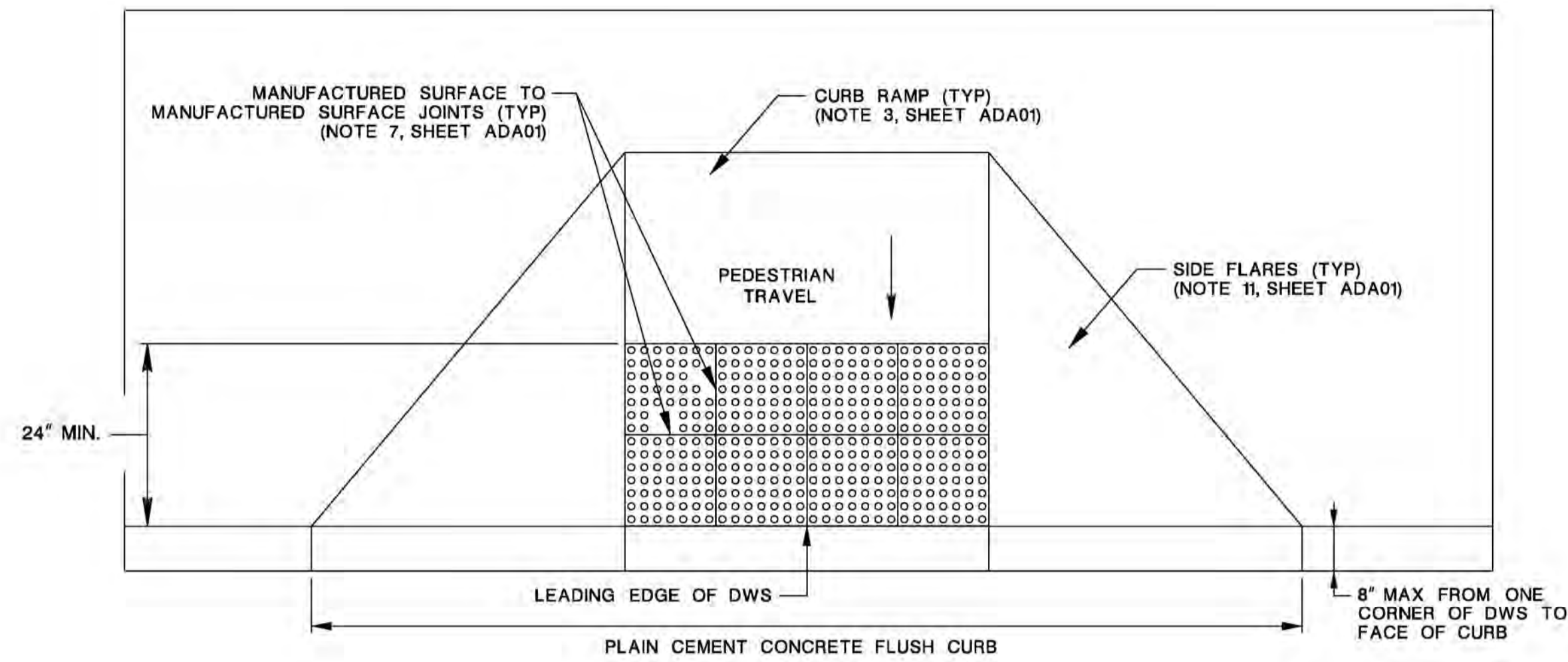
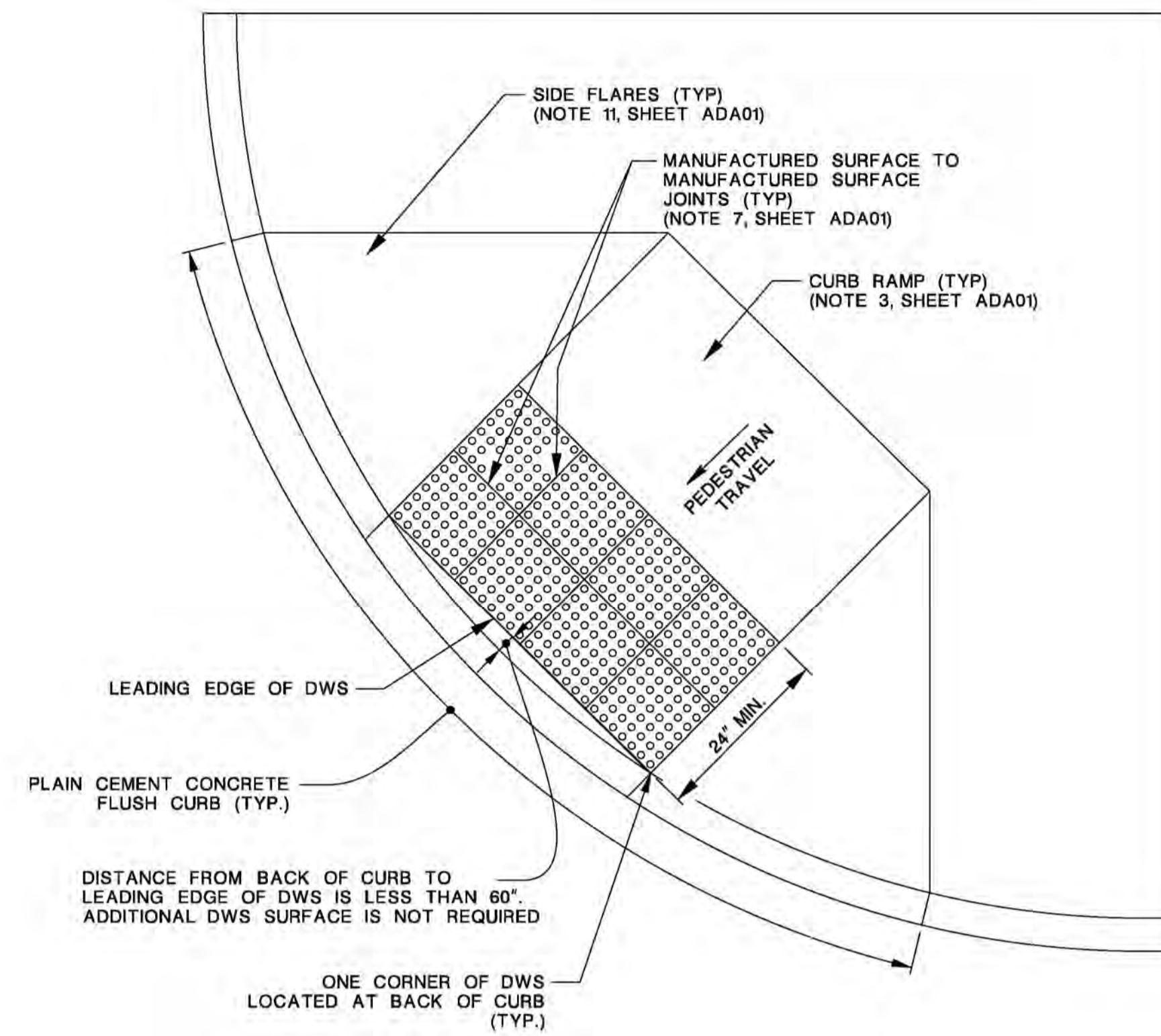
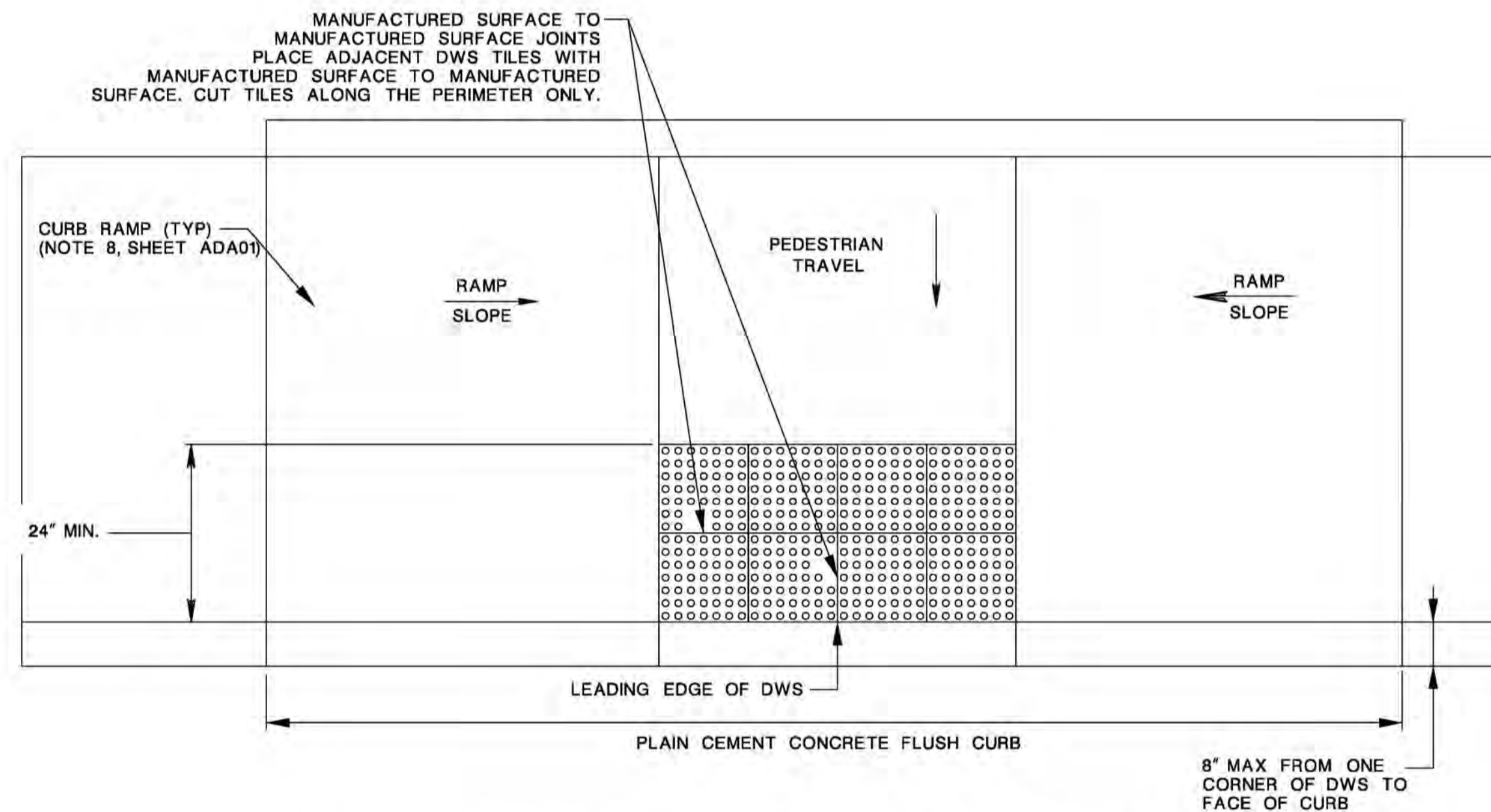

Illustration: Robert J. Schmitt, Inc. 1/10/00, 1/10/01, 1/10/02, 1/10/03, 1/10/04, 1/10/05, 1/10/06, 1/10/07, 1/10/08, 1/10/09, 1/10/10, 1/10/11, 1/10/12, 1/10/13, 1/10/14, 1/10/15, 1/10/16, 1/10/17, 1/10/18, 1/10/19, 1/10/20, 1/10/21, 1/10/22, 1/10/23, 1/10/24, 1/10/25, 1/10/26, 1/10/27, 1/10/28, 1/10/29, 1/10/30, 1/10/31, 1/10/32, 1/10/33, 1/10/34, 1/10/35, 1/10/36, 1/10/37, 1/10/38, 1/10/39, 1/10/40, 1/10/41, 1/10/42, 1/10/43, 1/10/44, 1/10/45, 1/10/46, 1/10/47, 1/10/48, 1/10/49, 1/10/50, 1/10/51, 1/10/52, 1/10/53, 1/10/54, 1/10/55, 1/10/56, 1/10/57, 1/10/58, 1/10/59, 1/10/60, 1/10/61, 1/10/62, 1/10/63, 1/10/64, 1/10/65, 1/10/66, 1/10/67, 1/10/68, 1/10/69, 1/10/70, 1/10/71, 1/10/72, 1/10/73, 1/10/74, 1/10/75, 1/10/76, 1/10/77, 1/10/78, 1/10/79, 1/10/80, 1/10/81, 1/10/82, 1/10/83, 1/10/84, 1/10/85, 1/10/86, 1/10/87, 1/10/88, 1/10/89, 1/10/90, 1/10/91, 1/10/92, 1/10/93, 1/10/94, 1/10/95, 1/10/96, 1/10/97, 1/10/98, 1/10/99, 1/10/100



DETECTABLE WARNING SURFACE (DWS) ON TYPE 1 CURB RAMP



DETECTABLE WARNING SURFACE (DWS) ON TYPE 2 CURB RAMP

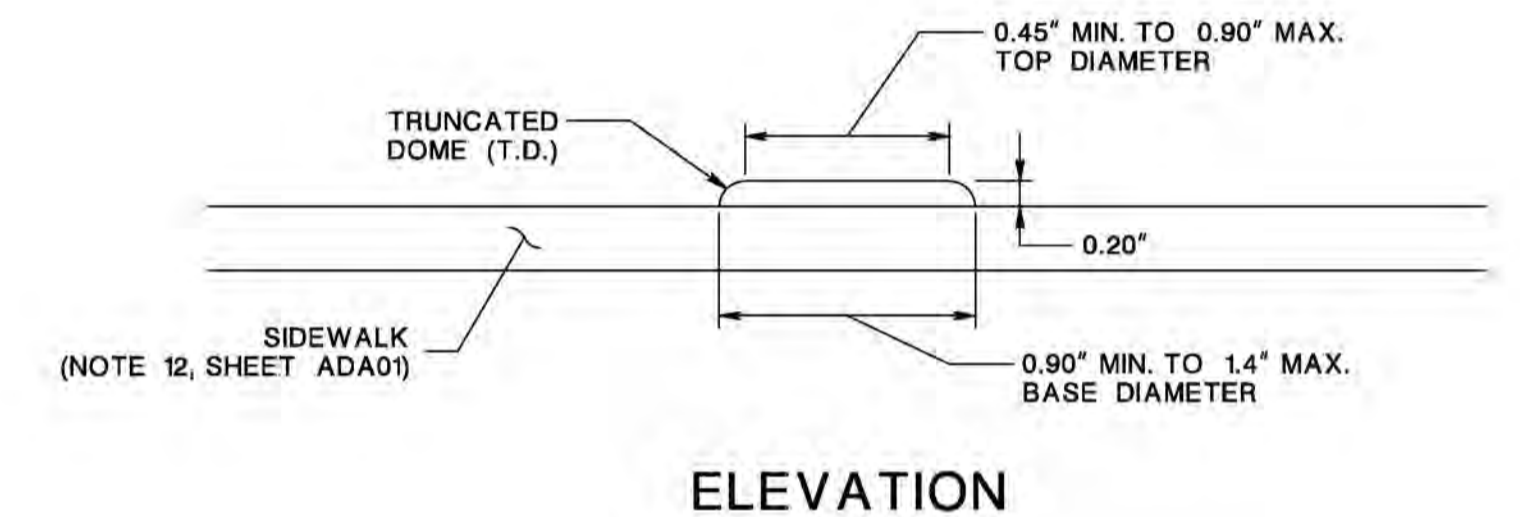
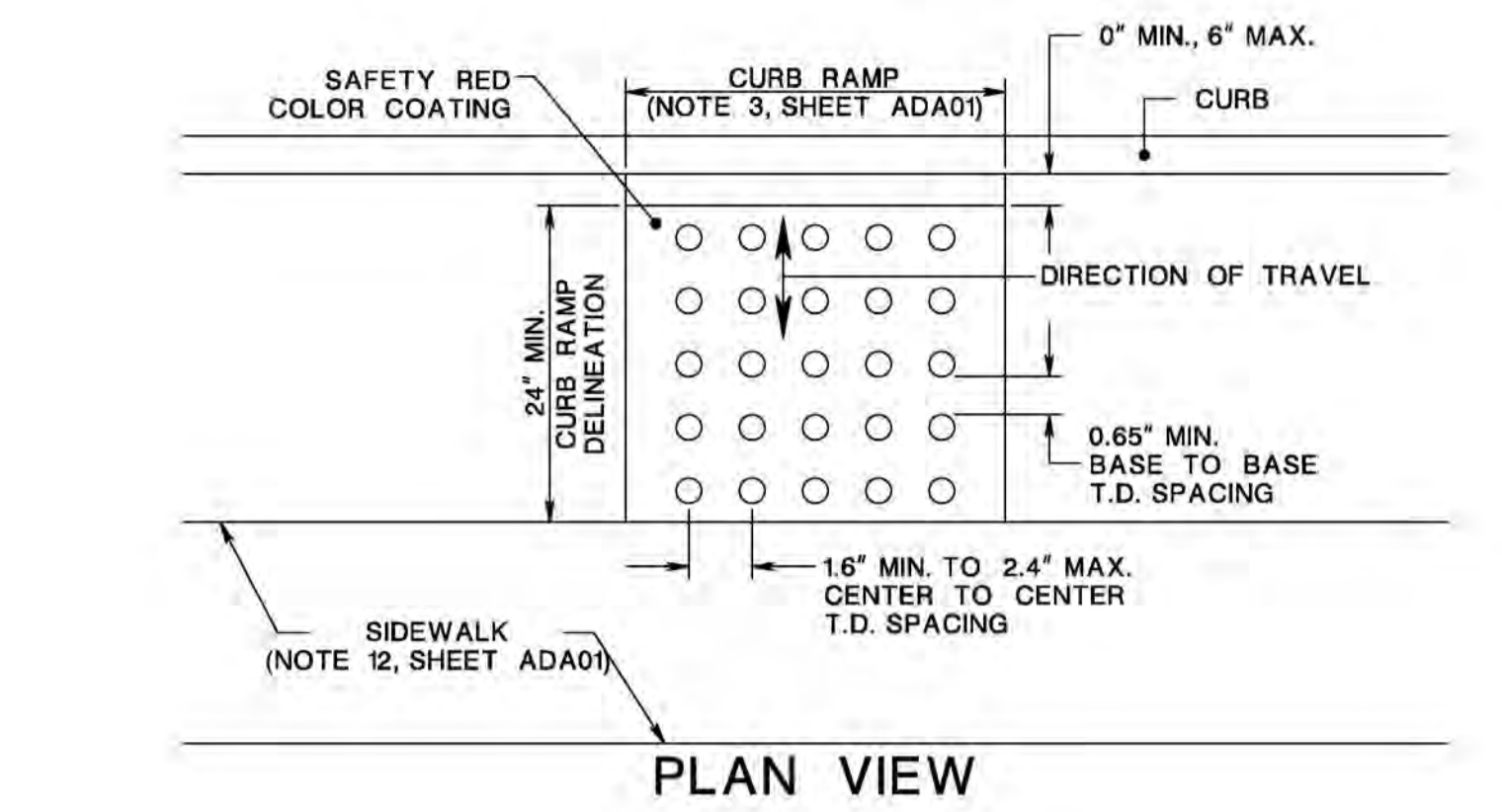

DETECTABLE WARNING SURFACE TRUNCATED DOME DETAILS

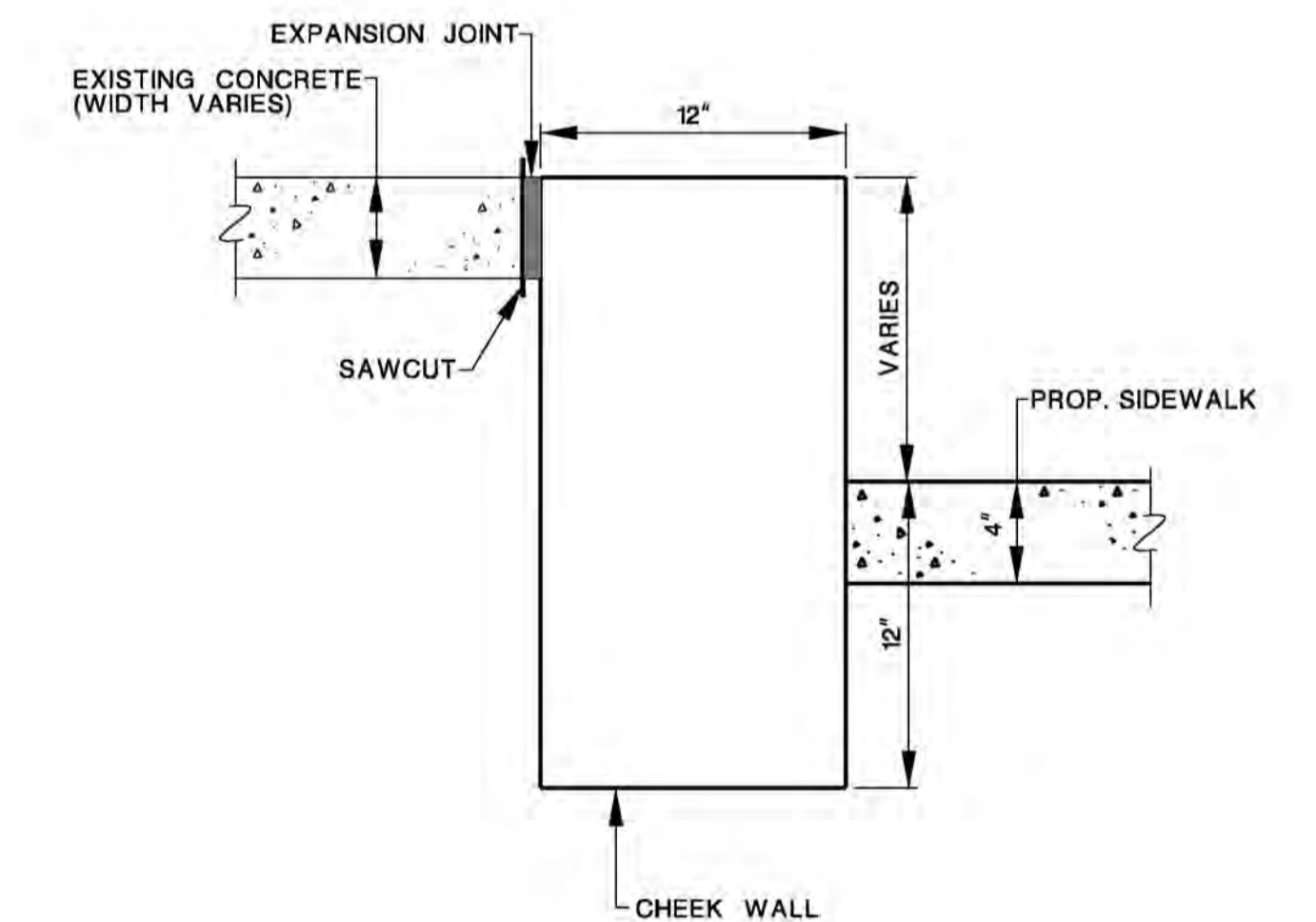

INSTALLATION OF SIDEWALK & CHEEK WALLS IN AN EXISTING CONCRETE ISLAND

CURB RAMPS AND SIDEWALKS

DETECTABLE WARNING SURFACE SPECIFICATIONS

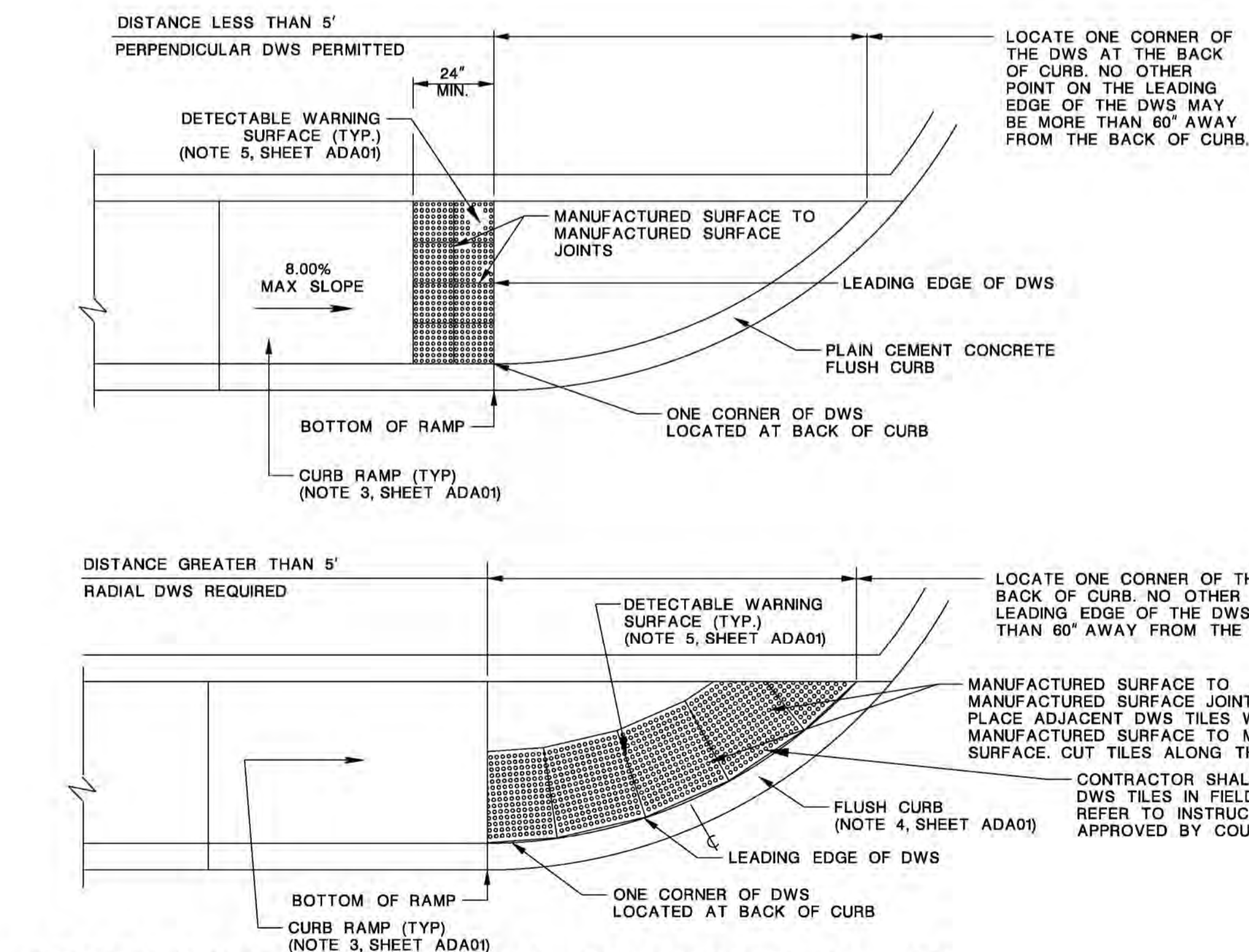

DETECTABLE WARNING SURFACE (DWS) ON CURVED SURFACES

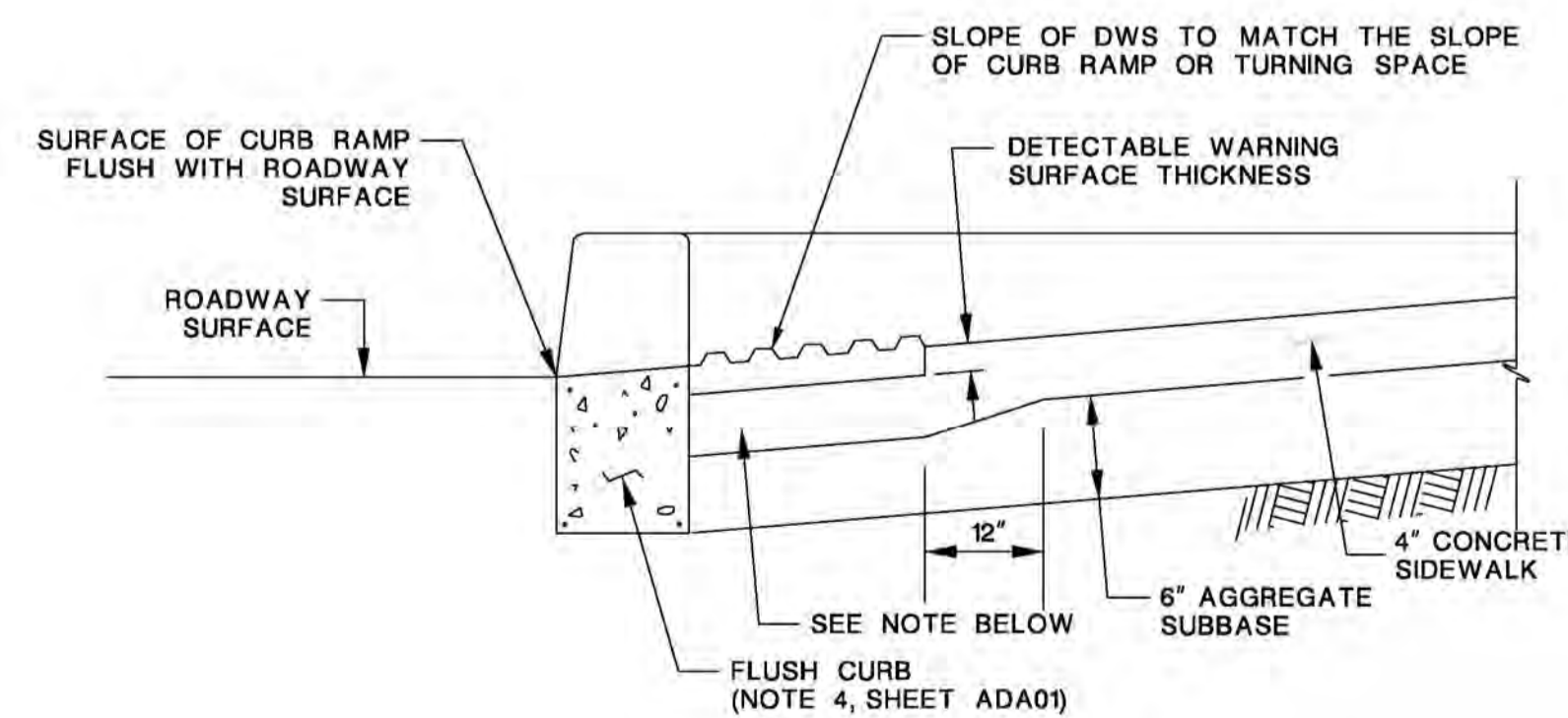

DETECTABLE WARNING SURFACE EMBEDDING DETAIL

NOTE: CONSTRUCT NOTCH AS SHOWN TO PROVIDE FULL THICKNESS SIDEWALK UNDER DETECTABLE WARNING SURFACE.

DATE	REVISIONS	BY	CHK.
 OCEAN COUNTY ADA DETAILS & SPECIFICATIONS JOHN N. ERNST COUNTY ENGINEER			
DETAILS FOR OCEAN COUNTY ADA CURB RAMP DETAILS			
DATE	DRAWN	CHECKED	DATE
SCALE	N.T.S.	APPROVED	F.S.B.
P.E. No. 33347			FILE NO. 1901
SHEET 19 OF 23			

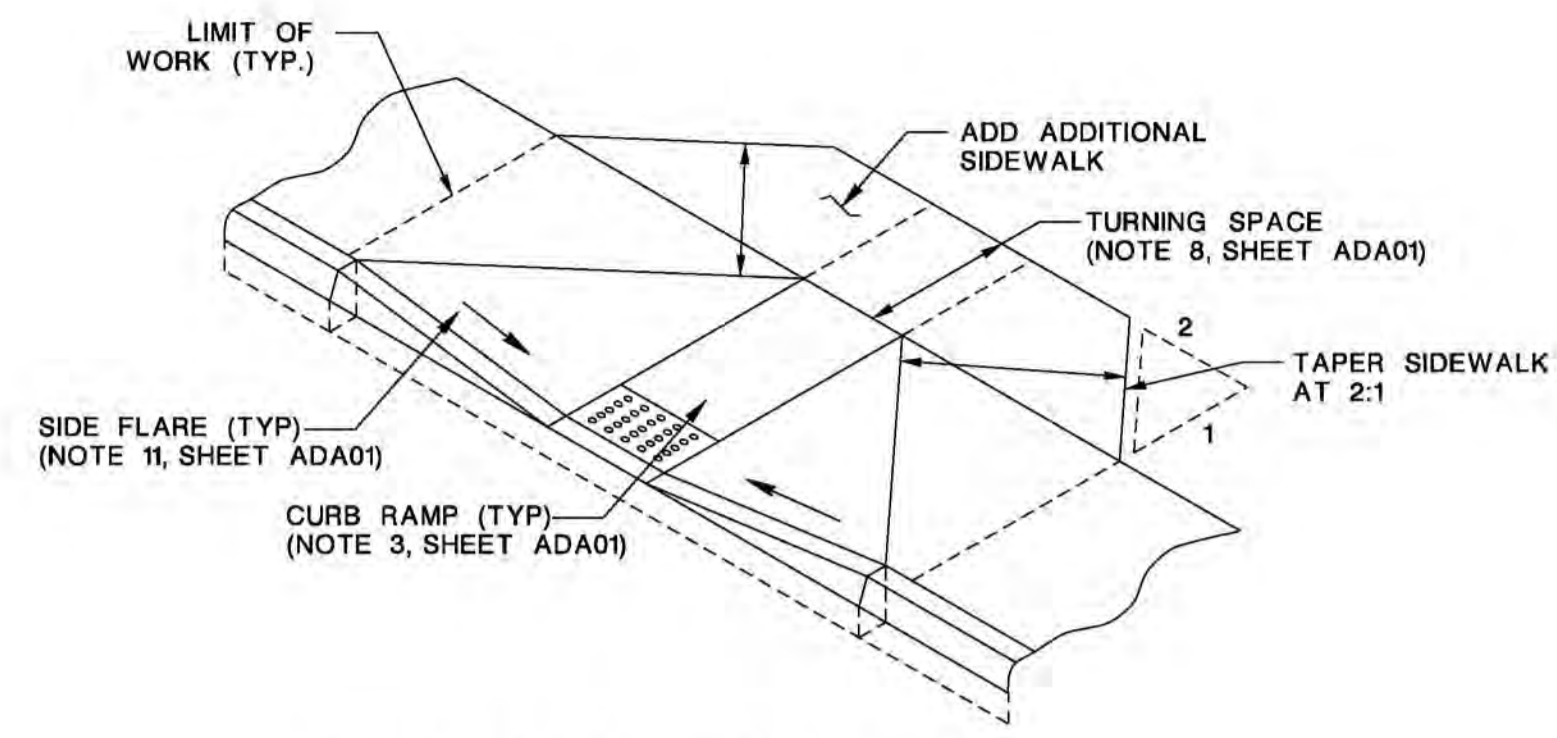

**TYPICAL TYPE 1
CURB RAMP
TURNING SPACE INSTALLATION**

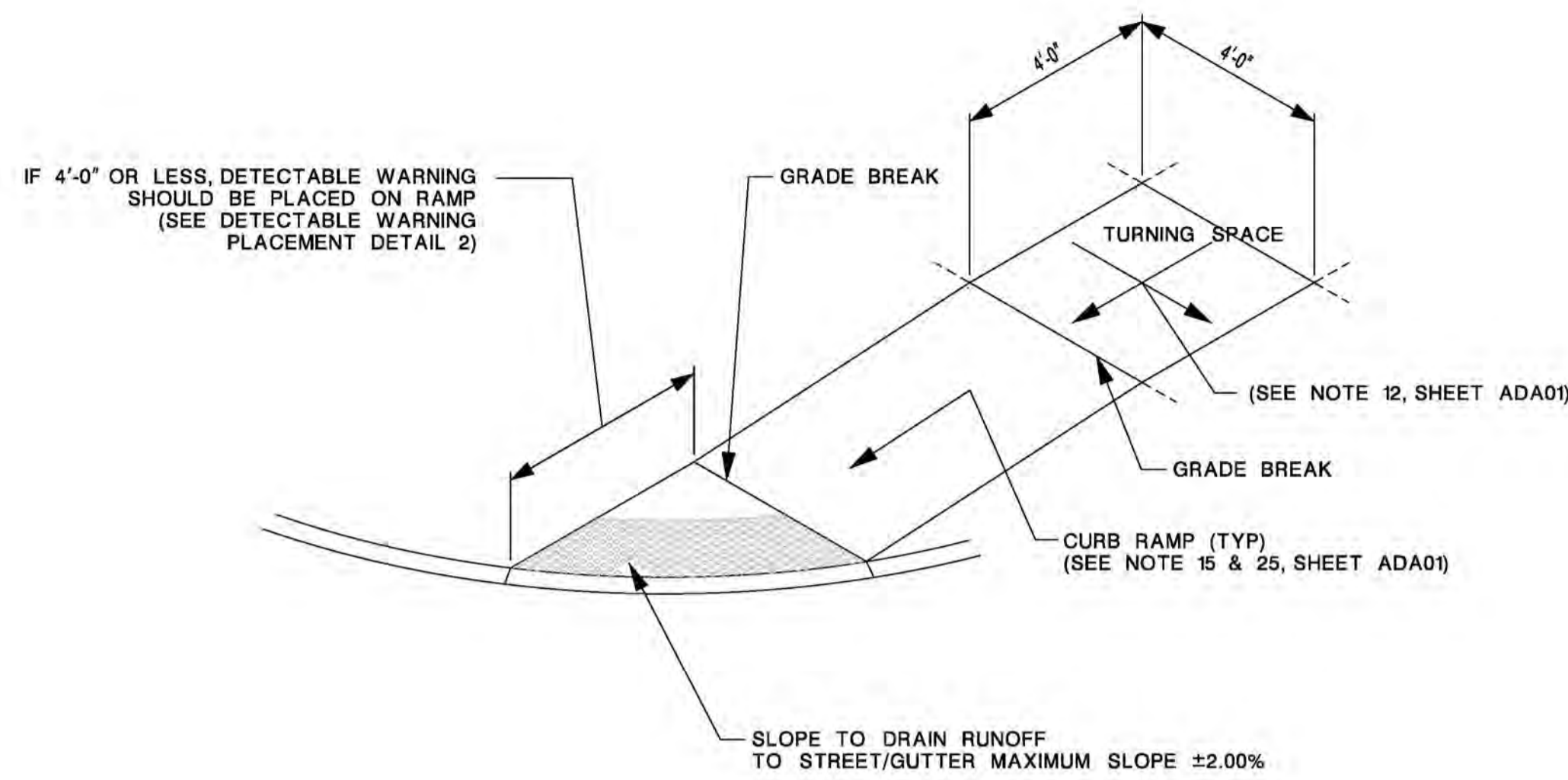

**CURB RAMP WITHOUT SIDE FLARES
TYPICAL DIMENSIONING**

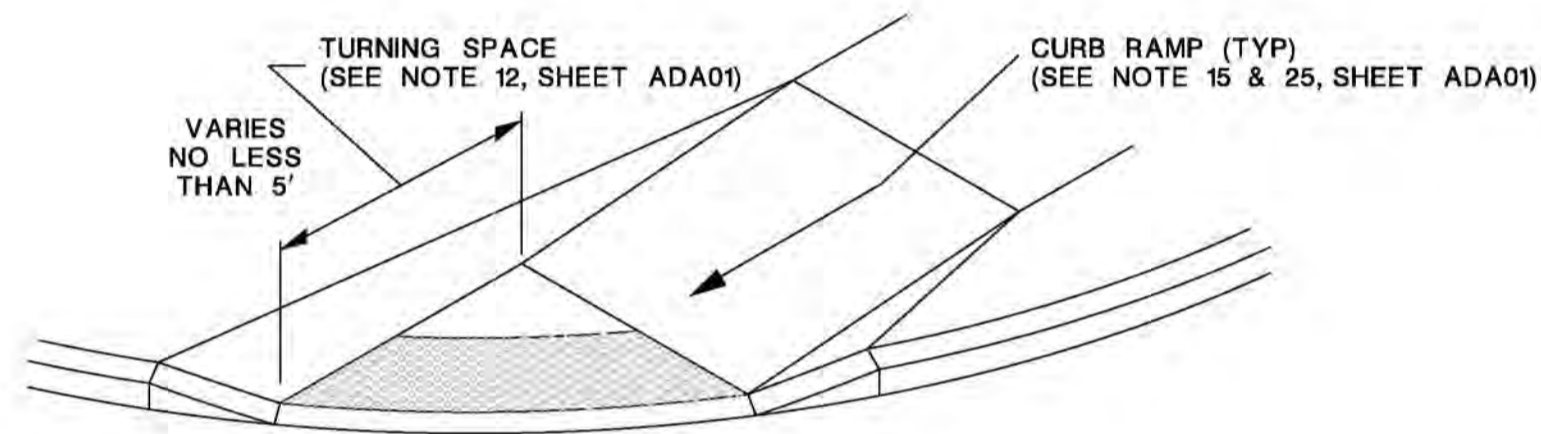

**TYPICAL TYPE 4
DETECTABLE WARNING PLACEMENT DETAIL 1**

NOTE: IF THE DISTANCE FROM THE GRADE BREAK IS GREATER THAN OR EQUAL TO 4'-0", DETECTABLE WARNINGS SHOULD BE PLACED ALONG THE RADIUS OF THE CURVE AS SHOWN IN THE ABOVE DETAIL.

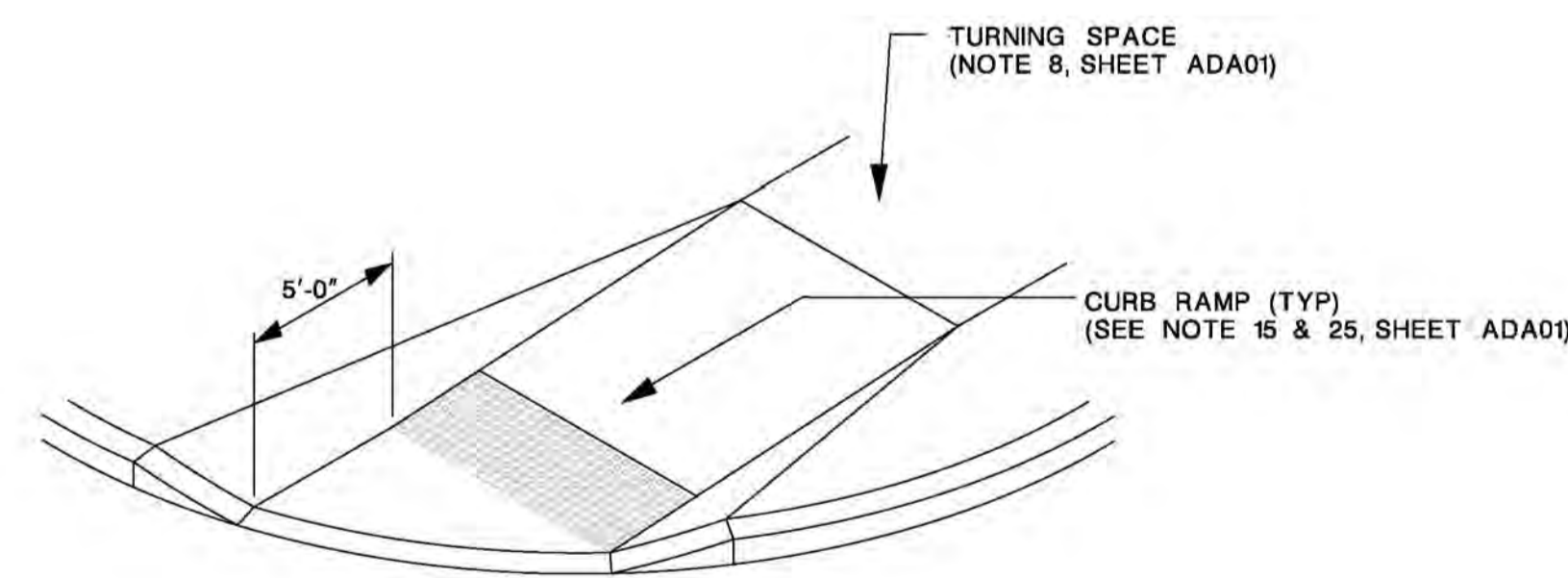

**TYPICAL TYPE 4
DETECTABLE WARNING PLACEMENT DETAIL 2**

NOTE: IF THE DISTANCE FROM THE GRADE BREAK IS LESS THAN OR EQUAL TO 4'-0", DETECTABLE WARNINGS SHOULD BE PLACED ON THE CURB RAMP ALONG THE BOTTOM GRADE BREAK WITH ONE CORNER 5" TO 8" FROM THE FRONT OF THE CURB OR EDGE OF THE ROADWAY.

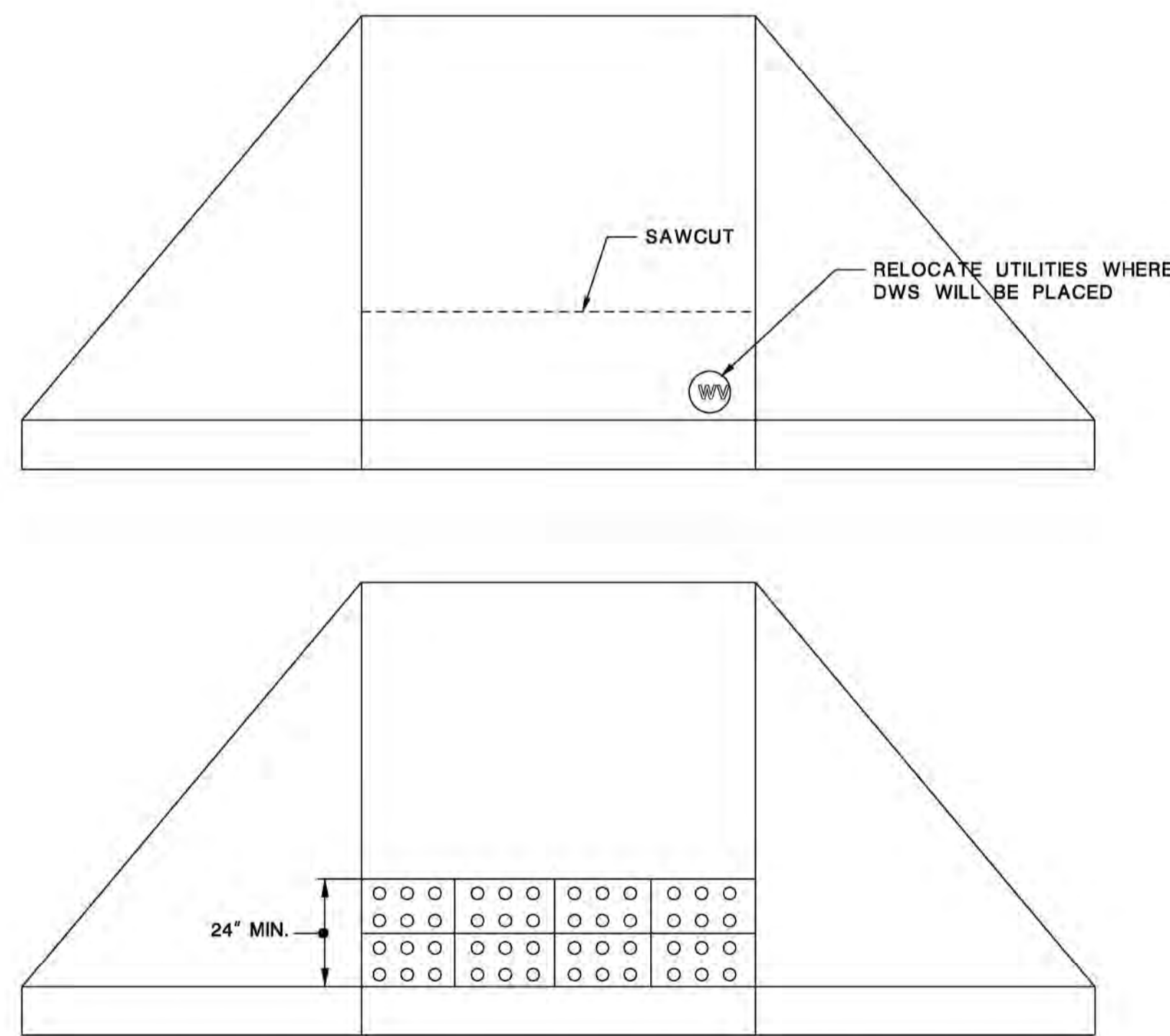

**DETECTABLE WARNING SURFACE (DWS)
INSTALLATION DETAIL**

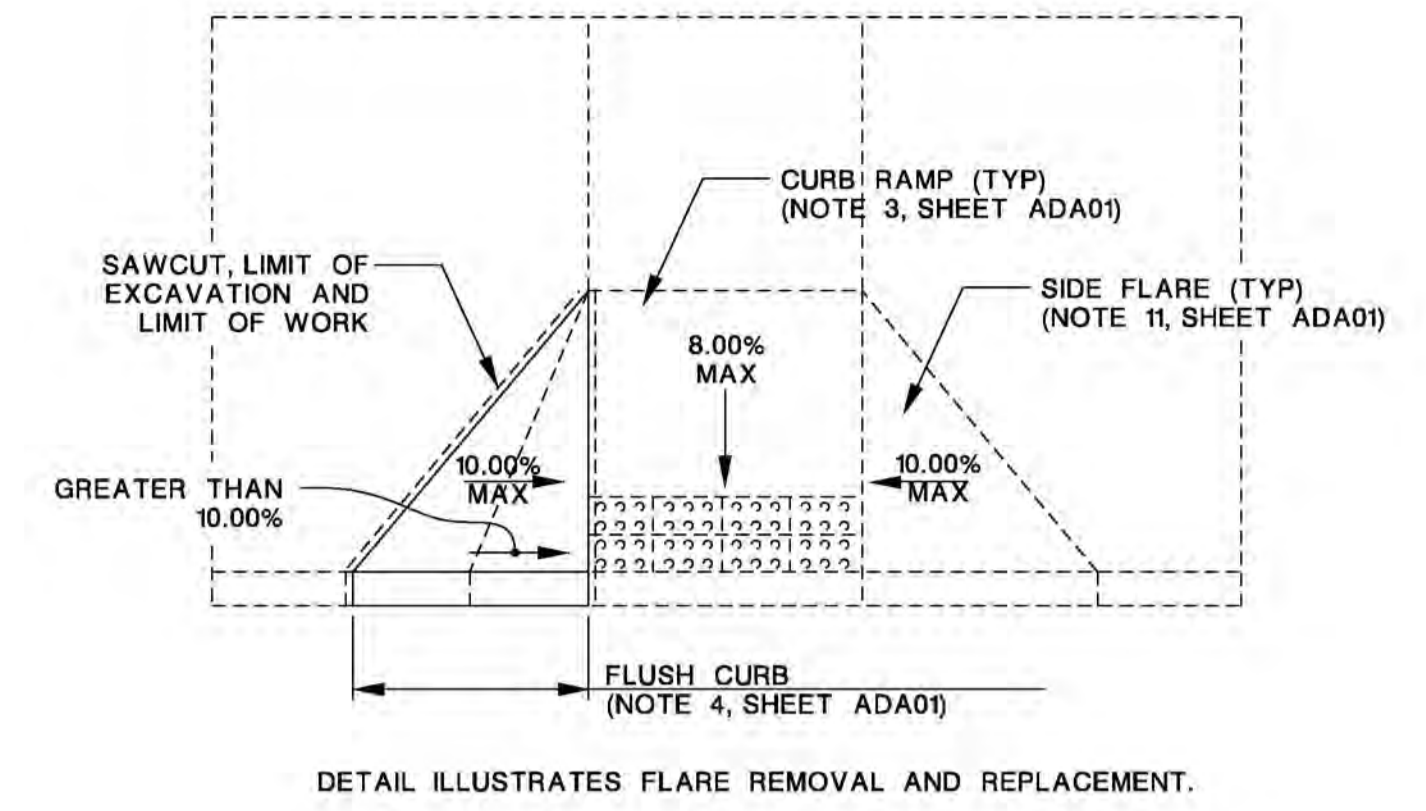

**SIDE FLARE
RECONSTRUCTION**

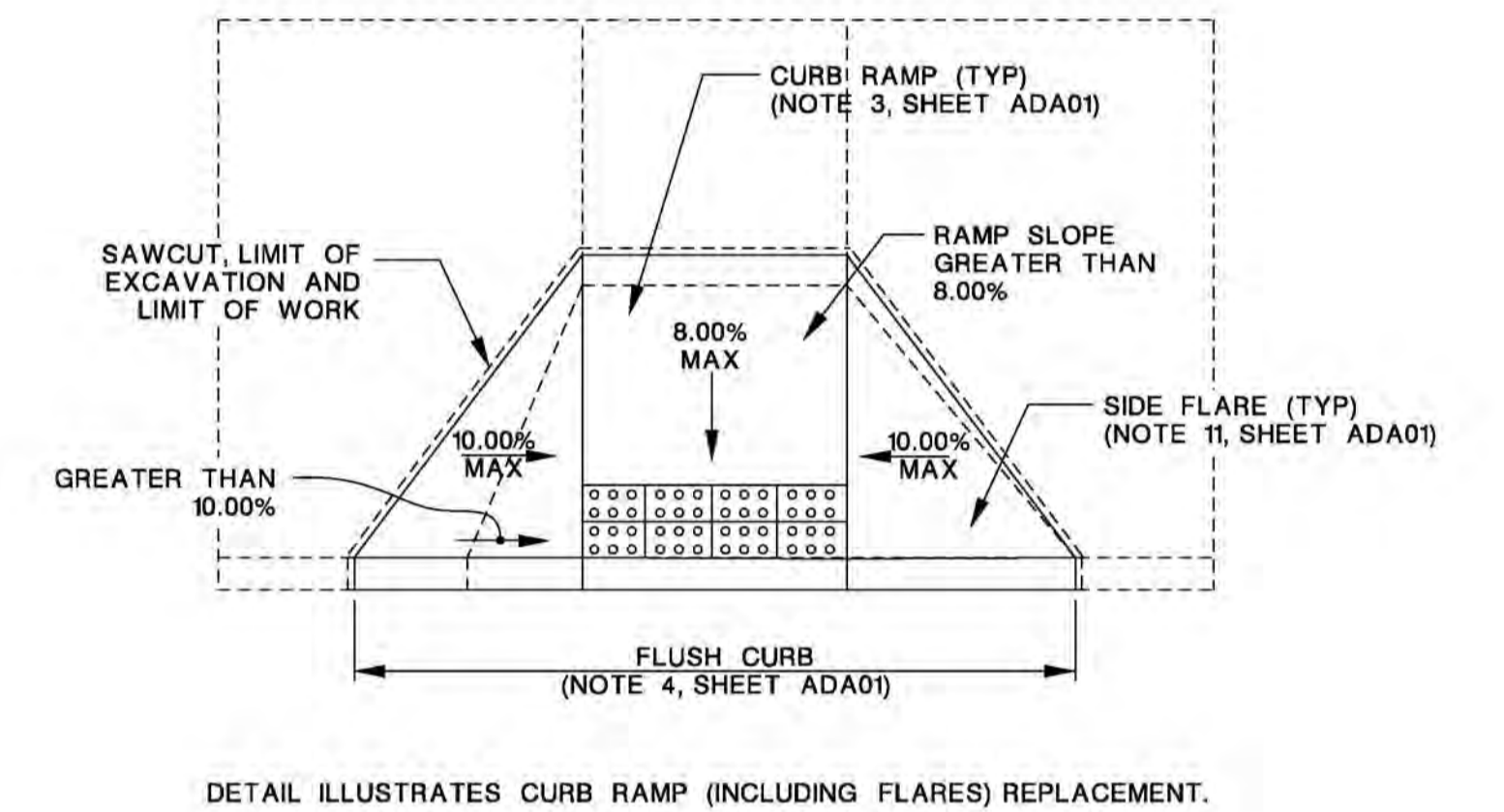

DETAIL ILLUSTRATES CURB RAMP (INCLUDING FLARES) REPLACEMENT.

**TOTAL RAMP
RECONSTRUCTION**

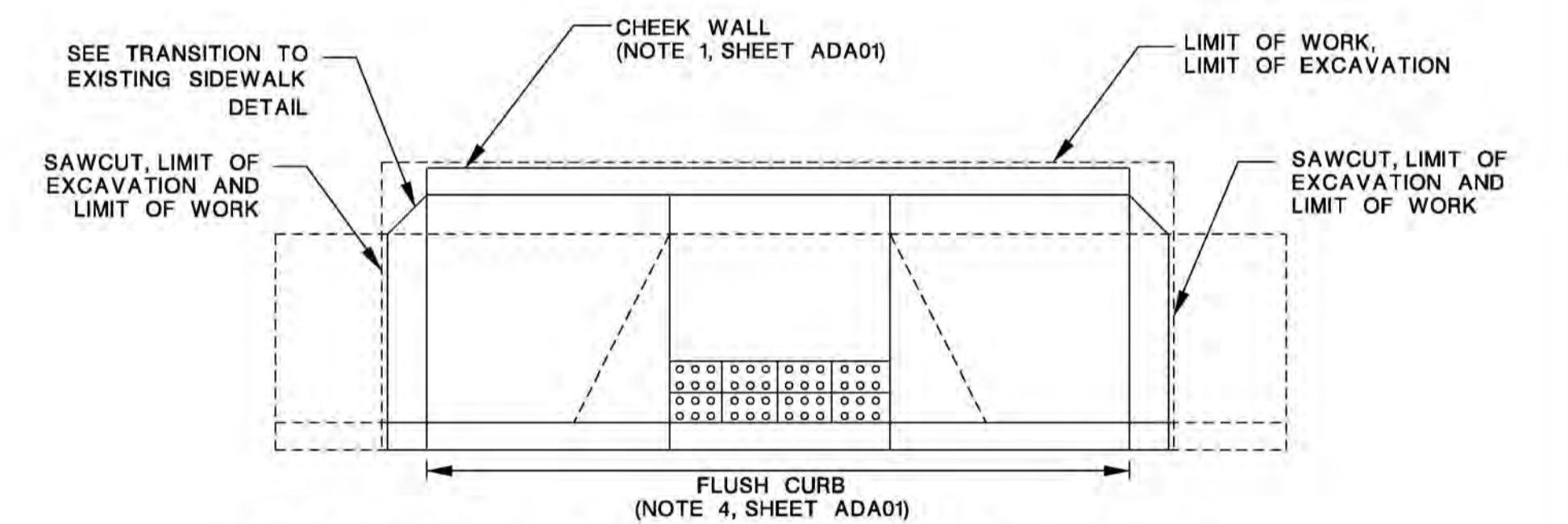

DETAIL ILLUSTRATES A TYPE 1 EXISTING RAMP REPLACED WITH A TYPE 2 RAMP. USE THIS DETAIL AS AN EXAMPLE TO REPLACE ANY RAMP WITH A DIFFERENT CURB RAMP TYPE.

**TOTAL RAMP
RECONSTRUCTION
(RAMP TYPE CHANGE)**

CURB RAMPS AND SIDEWALKS

**DETECTABLE WARNING SURFACE
SPECIFICATIONS**

DATE		REVISIONS		BY	CHK.
 OCEAN COUNTY ADA DETAILS & SPECIFICATIONS ADA CURB RAMP DETAILS					
DATE	BY	DESIGNED	***	CHECKED	CRM
SCALE	N.T.S.	DRAWN	***	APPROVED	F.S.B.
FILE NO. 194					SHEET 20 OF 23

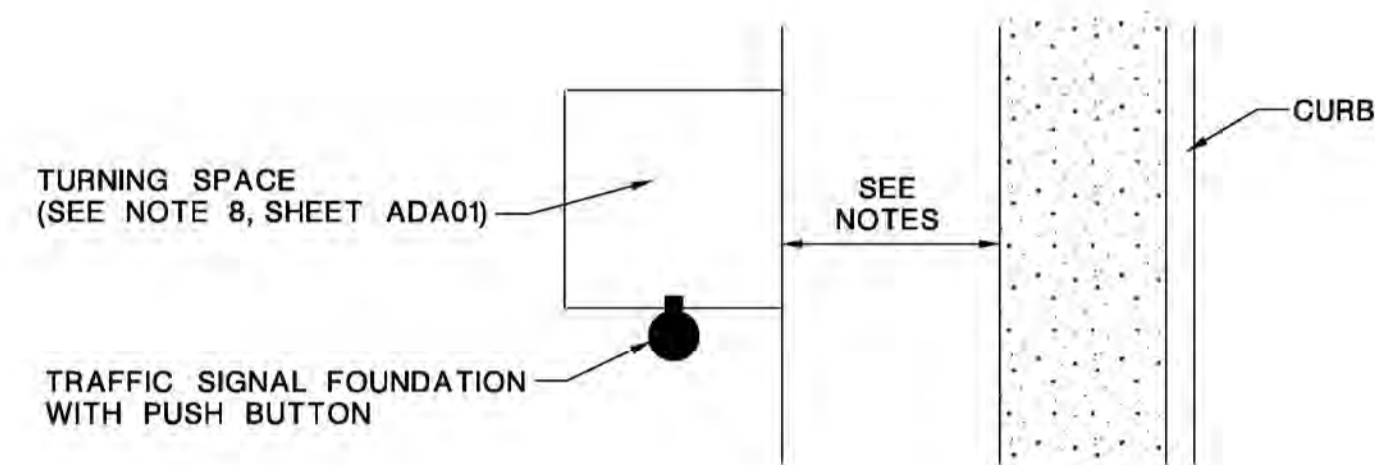

NOTES:

1. TURNING SPACE CENTERED BY PUSH BUTTON & CONNECTED TO PEDESTRIAN PATH/FACILITIES.
2. LOCATION OF PUSH BUTTON IN REFERENCE TO THE CROSSWALK MUST BE M.U.T.C.D. & A.D.A. COMPLIANT.

PEDESTRIAN ACCESS TO PUSH BUTTONS

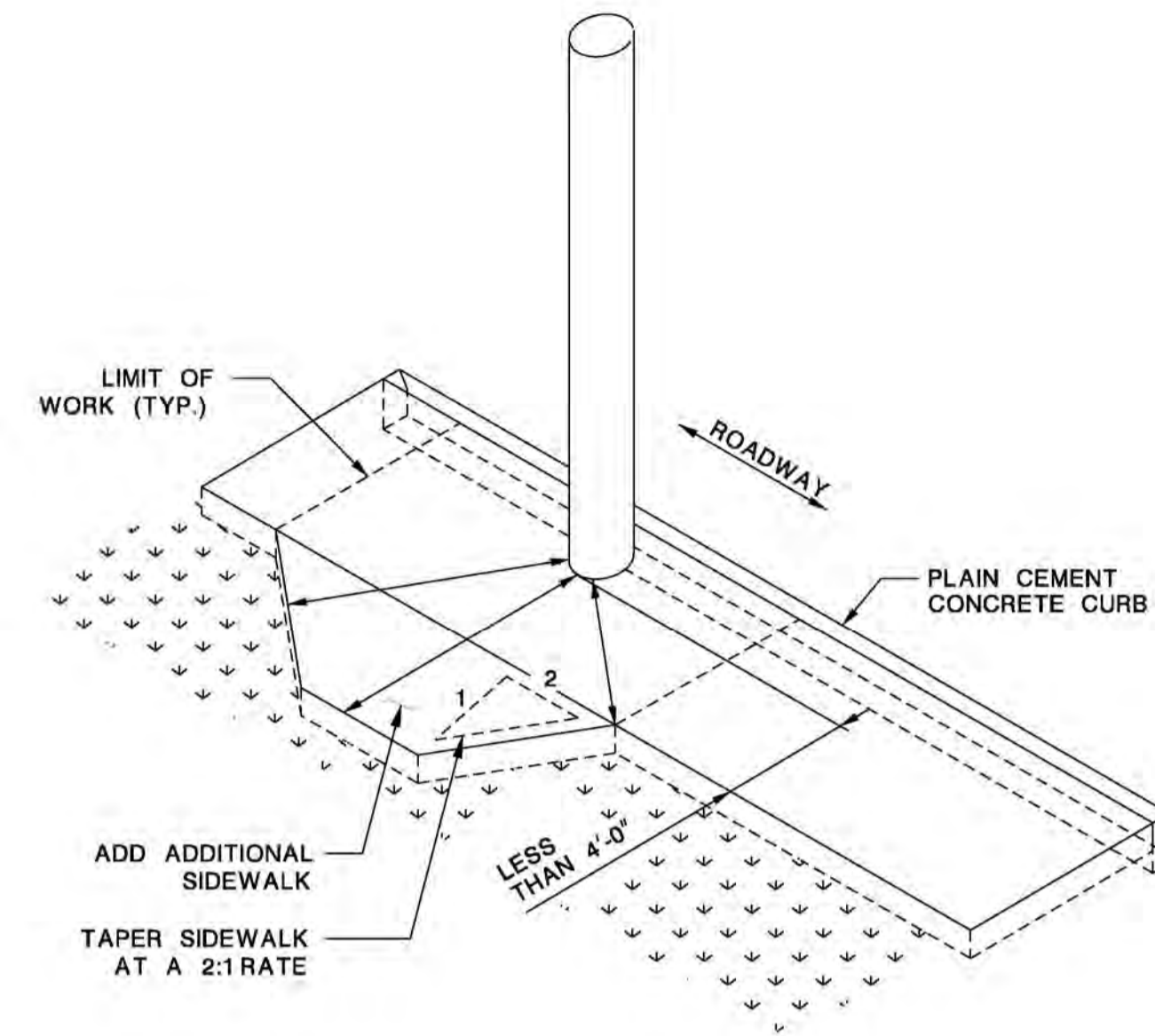

SIDEWALK ADDITION DUE TO OBSTRUCTIONS
(REQUIRES OCEAN COUNTY ENGINEERING DEPARTMENT APPROVAL)

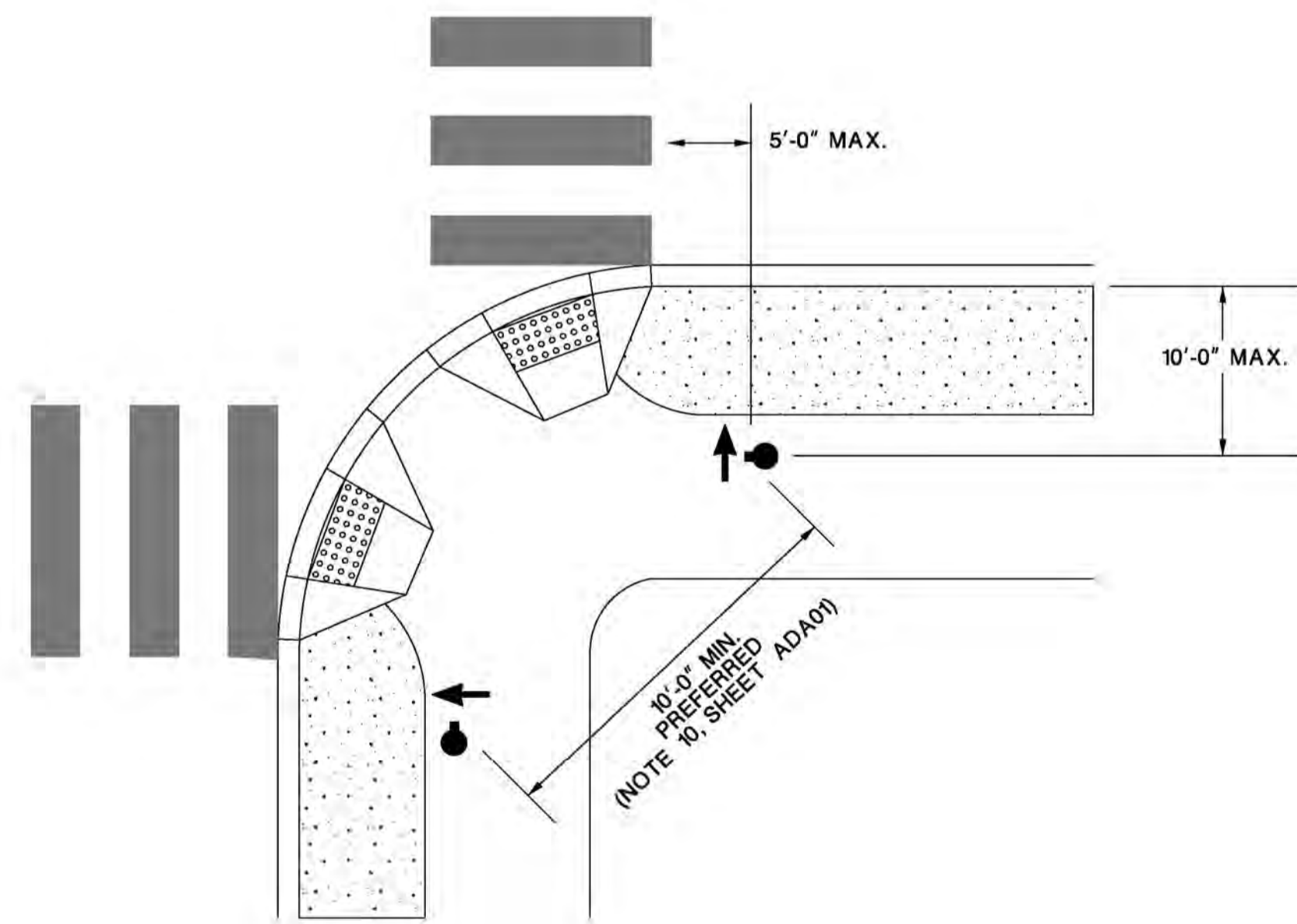

RECOMMENDED PUSH BUTTON LOCATIONS

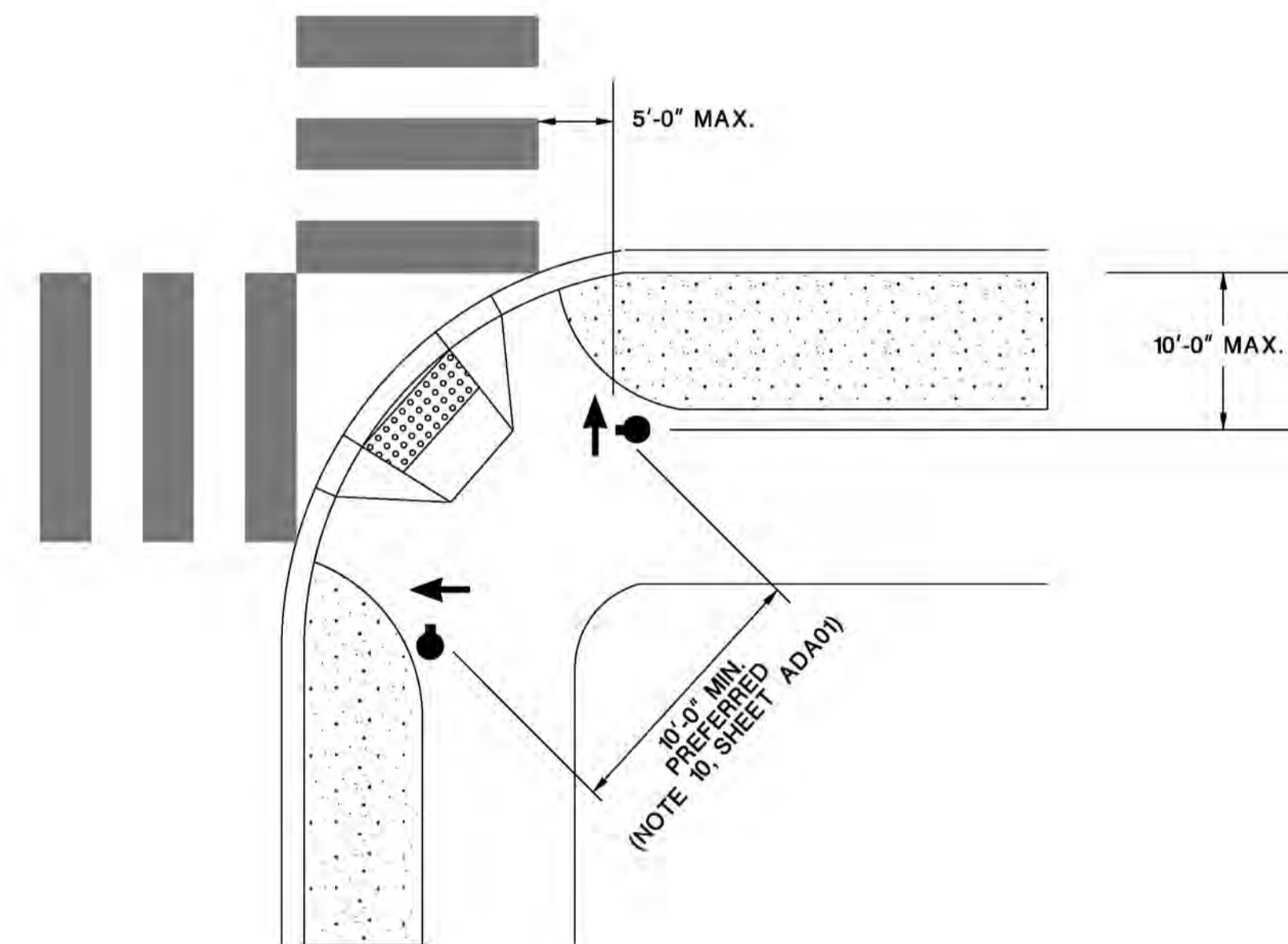

RECOMMENDED PUSH BUTTON LOCATIONS

LEGEND

 PEDESTRIAN PUSH BUTTON

CURB RAMPS AND SIDEWALKS
 PUSH BUTTON

DATE		REVISIONS		BY	CHK.
DETAILS FOR					
OCEAN COUNTY					
ADA DETAILS & SPECIFICATIONS					
ADA CURB RAMP DETAILS					
DATE	DESIGNED	***	CHECKED	DRW	
SCALE	N.T.S.	DRAWN	***	APPROVED	F.S.B.
FILE NO. 1991					SHEET 21 OF 23

ADA21
 ADA23

JOHN N. ERNST
 COUNTY ENGINEER

P.E. No. 33347

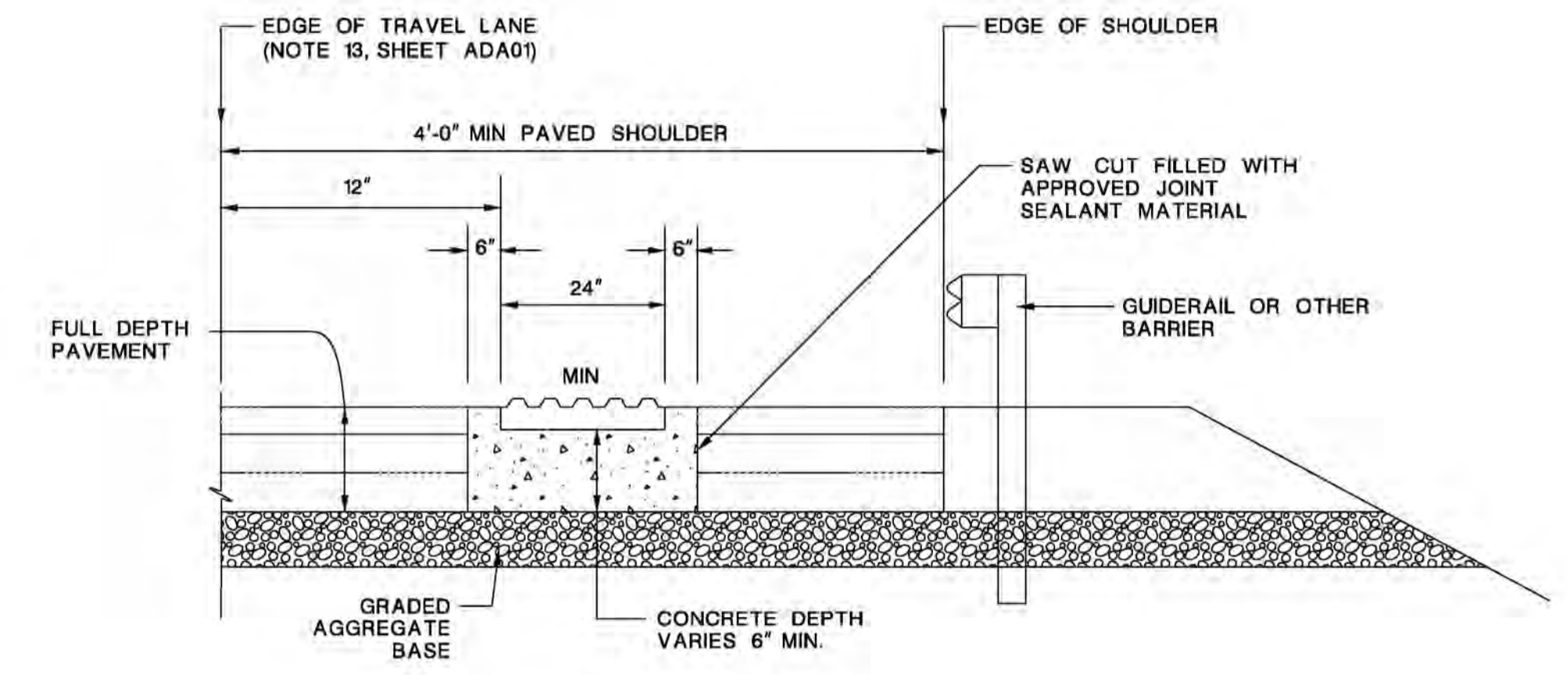

SECTION C-C

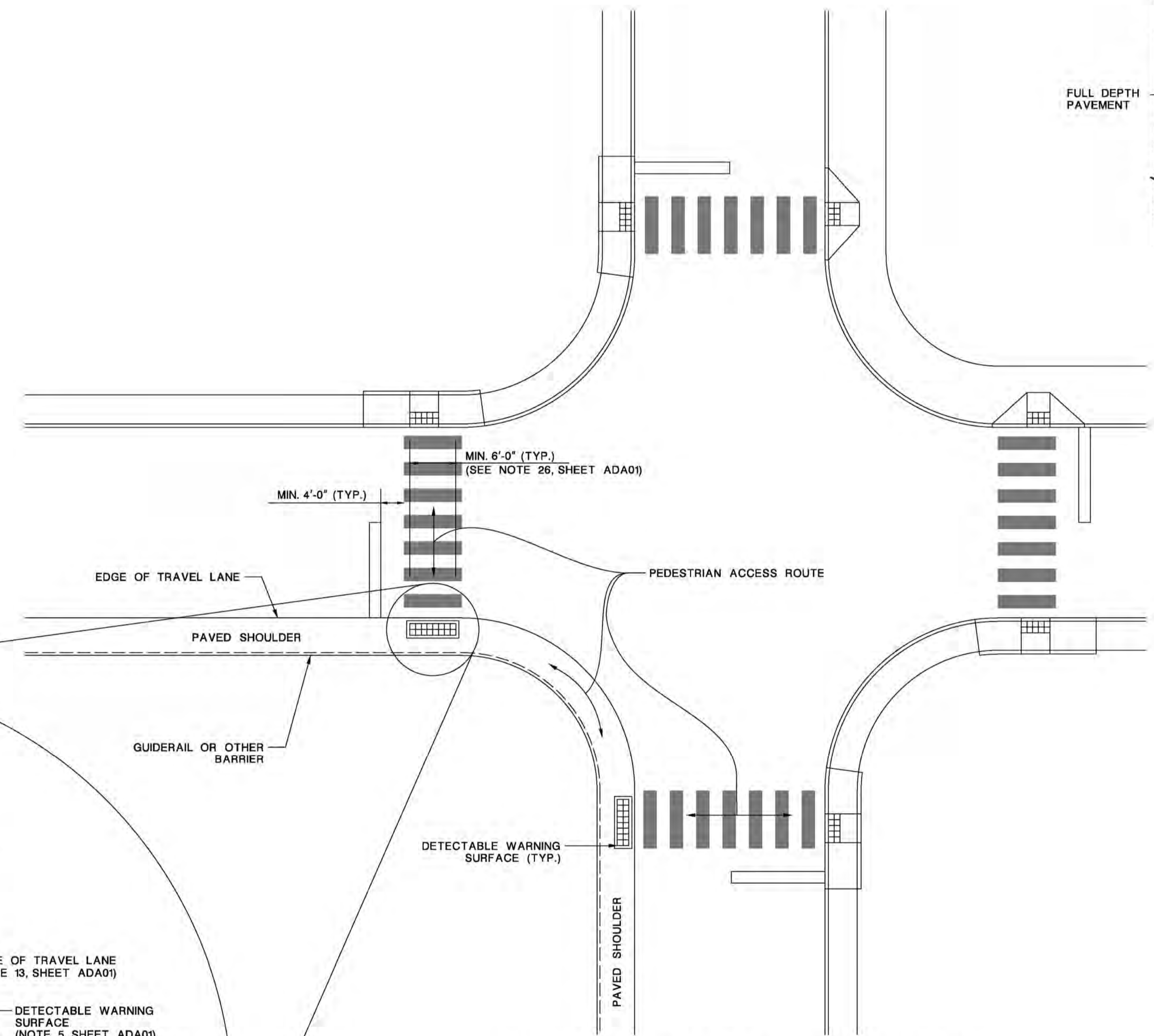

TYPICAL INTERSECTION PLAN WITH DWS ON PAVED SHOULDERS WITH BARRIERS (SHARED USE SHOULDERS)

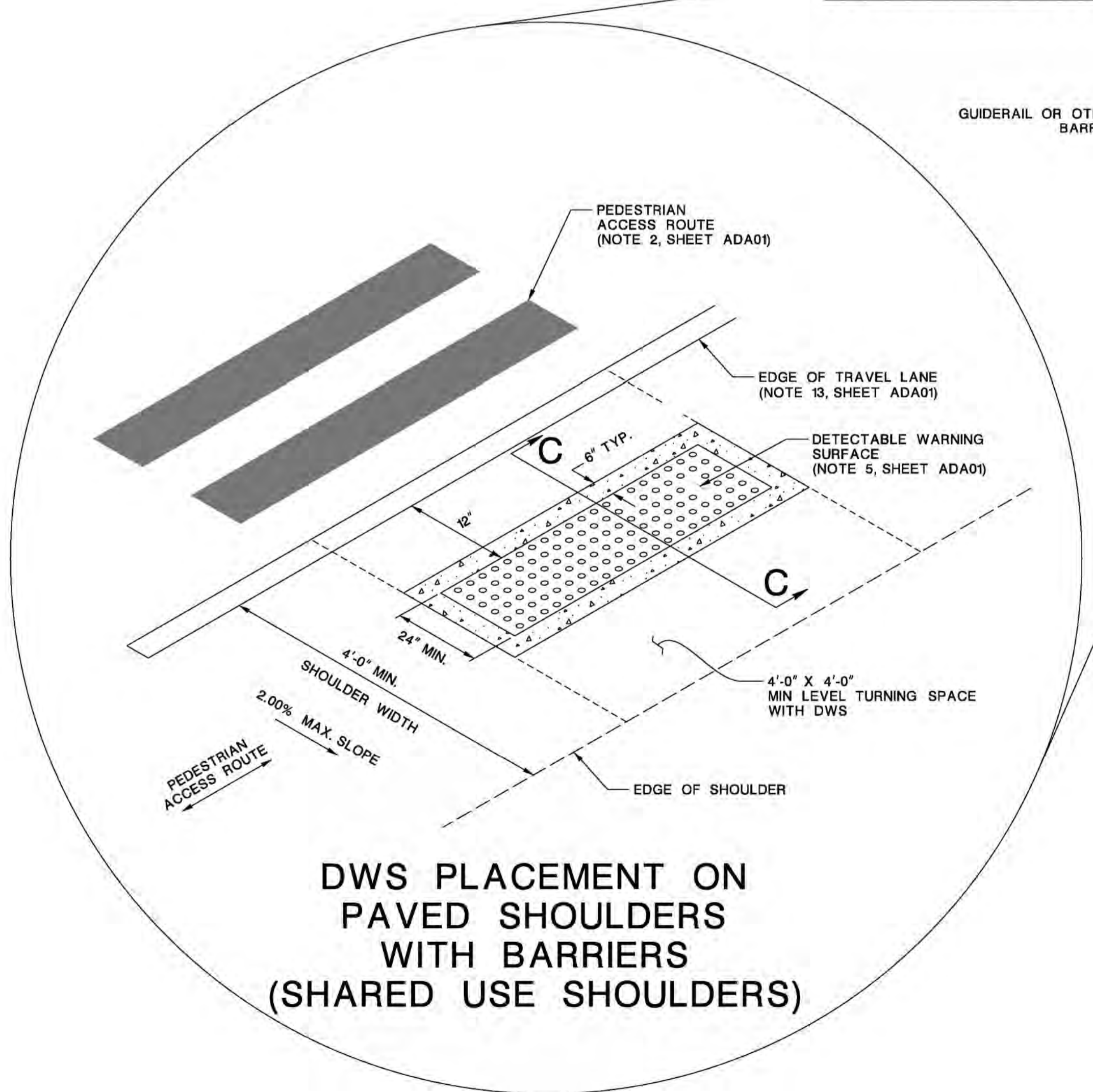

DWS PLACEMENT ON PAVED SHOULDERS WITH BARRIERS (SHARED USE SHOULDERS)

CURB RAMPS AND SIDEWALKS

TYPICAL INTERSECTION

DATE	REVISIONS	BY	CHK.
DETAILS FOR			
OCEAN COUNTY			
ADA DETAILS & SPECIFICATIONS			
ADA CURB RAMP DETAILS			
DATE	DRAWN	CHECKED	DATE
SCALE	N.T.S.	APPROVED	F.S.S.
 JOHN N. ERNST COUNTY ENGINEER			SHEET 22 of 23

11/20/2014 10:00 AM 11/20/2014 10:00 AM 11/20/2014 10:00 AM

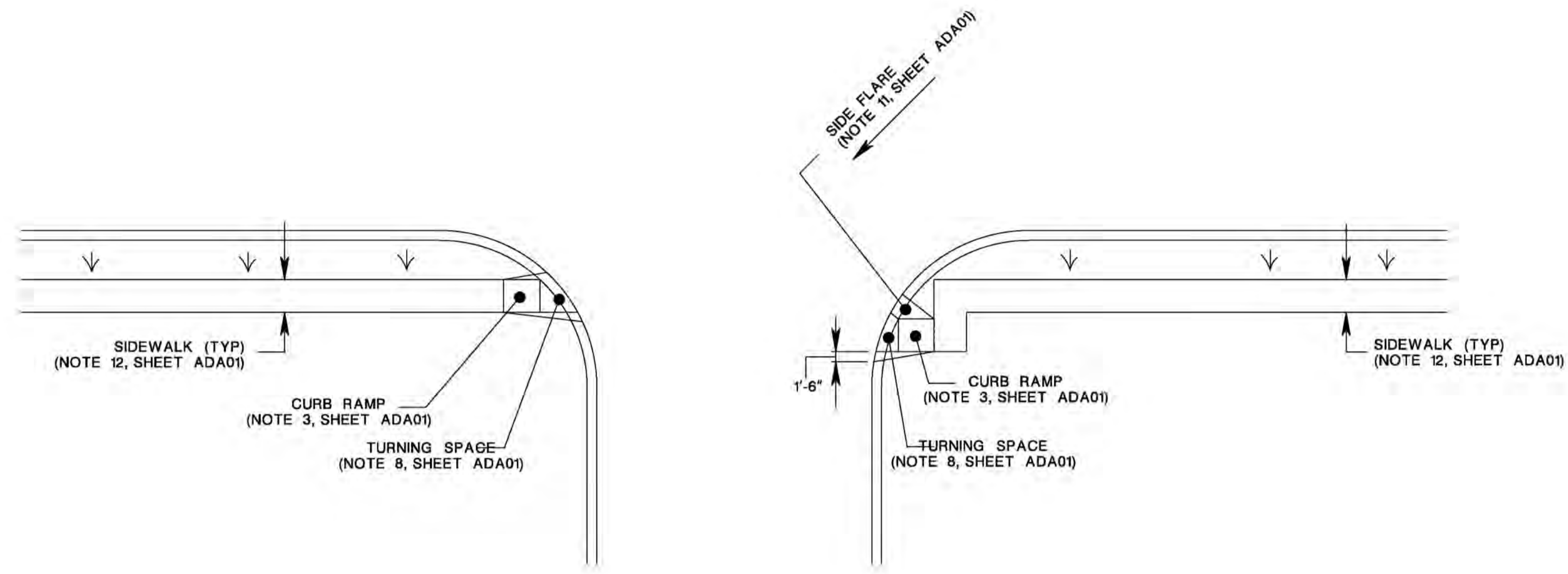

ALTERNATE TREATMENT
(NOTE 16, SHEET ADA01)

PREFERRED TREATMENT
(NOTE 16, SHEET ADA01)

**CURB RAMP
CROSSING PARALLEL TO HIGHWAY**

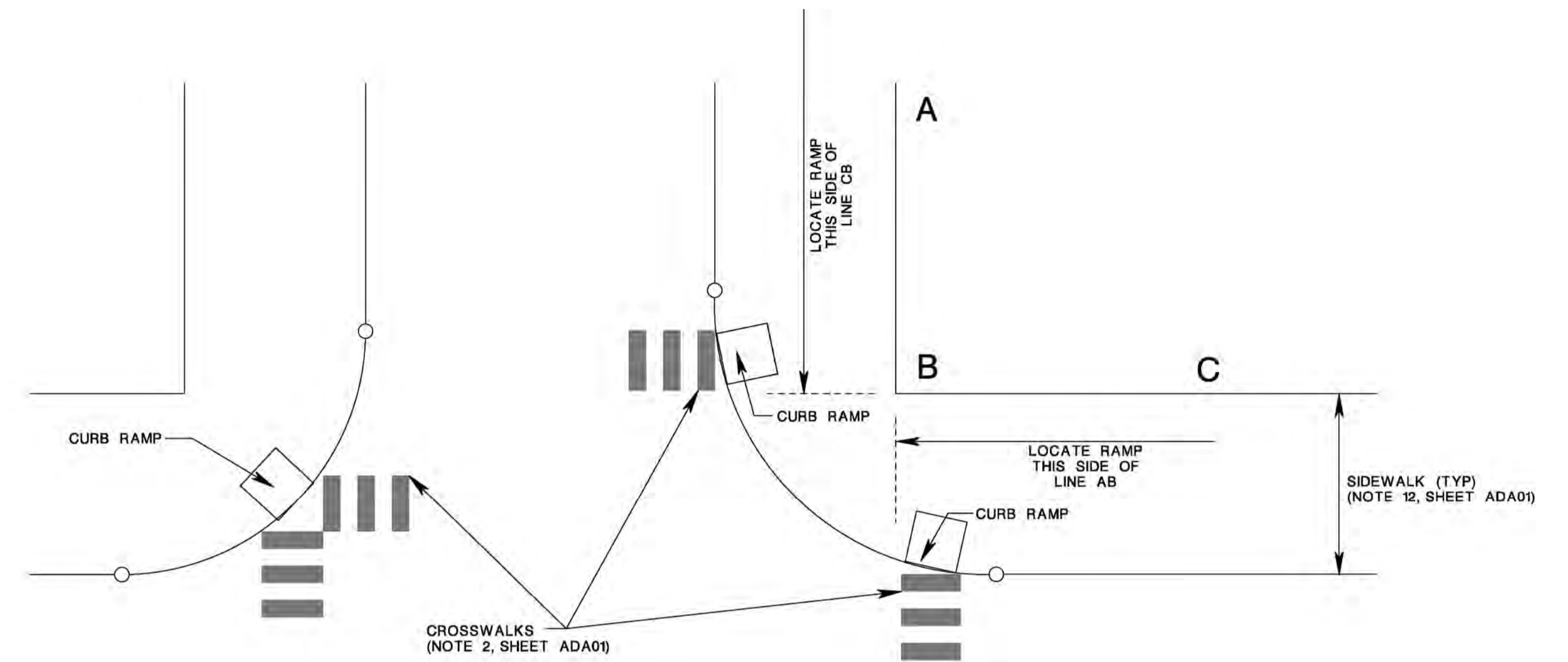

ALTERNATE TREATMENT
(NOTE 16, SHEET ADA01)

PREFERRED TREATMENT
(NOTE 16, SHEET ADA01)

**LOCATION OF CURB RAMP
FOR CROSSING PARALLEL AND PERPENDICULAR
TO HIGHWAY**

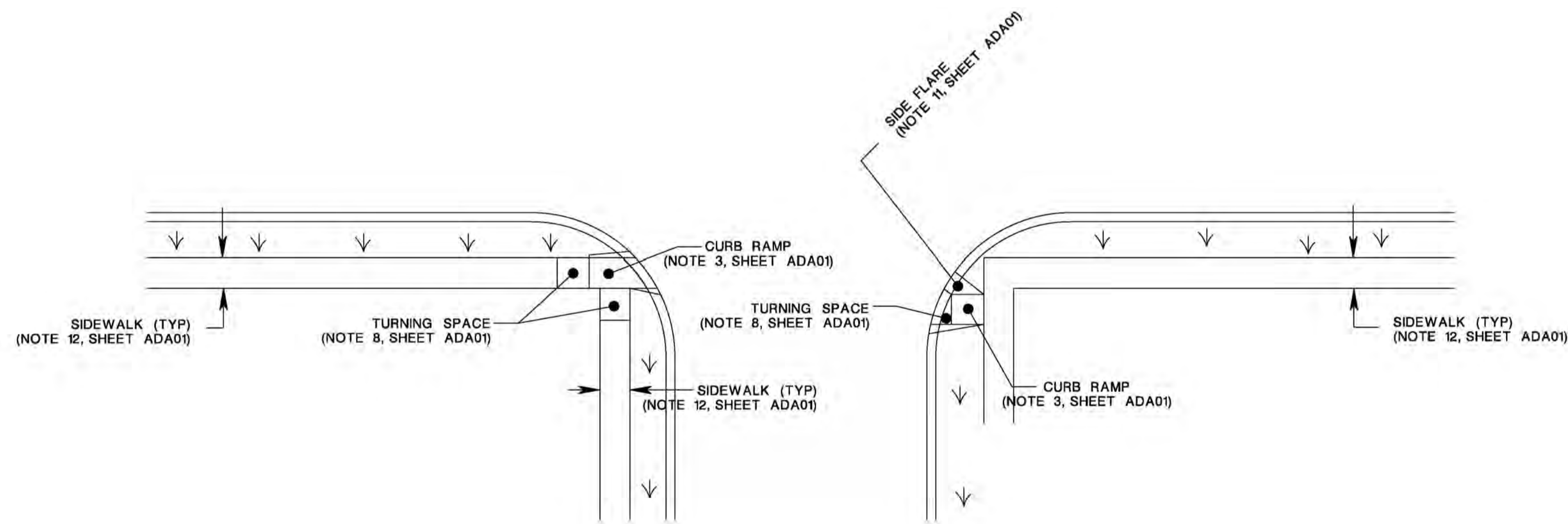

ALTERNATE TREATMENT
(NOTE 16, SHEET ADA01)

PREFERRED TREATMENT
(NOTE 16, SHEET ADA01)

**CURB RAMP
CROSSING PARALLEL TO HIGHWAY ONLY**

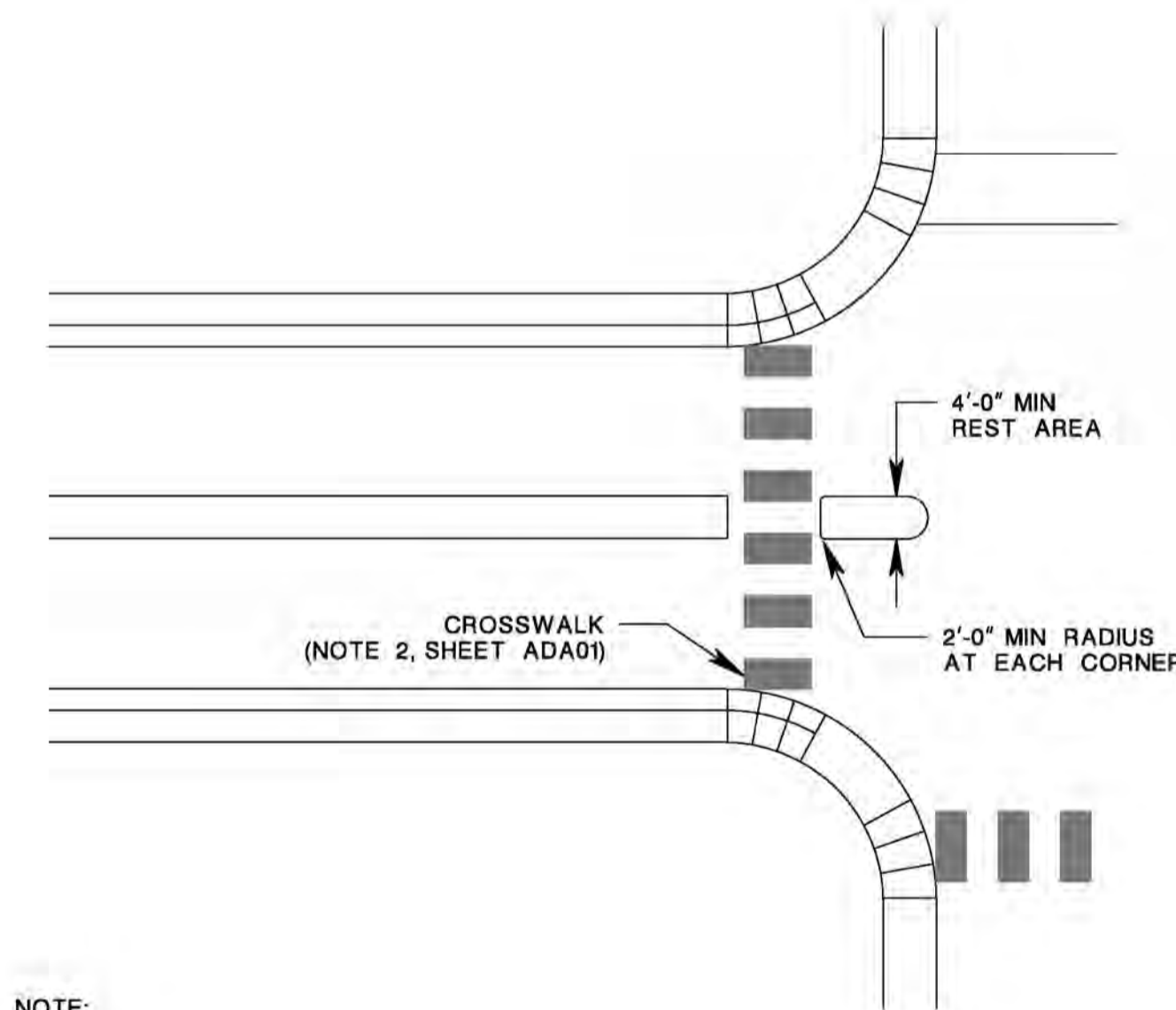

NOTE:
WHERE PRACTICAL, END LEFT TURN ISLAND
OR DIVISIONAL ISLAND BEFORE CROSSWALK
TO ELIMINATE CUT-THROUGH

**ISLAND WALKWAY OPENING
AT INTERSECTION**

CURB RAMPS AND SIDEWALKS

TYPICAL INTERSECTION

DATE	REVISIONS	BY	CHK.
DETAILS FOR			
OCEAN COUNTY			
ADA DETAILS & SPECIFICATIONS			
ADA CURB RAMP DETAILS			
DATE	DESIGNED	CHECKED	DRW.
SCALE	N.T.S.	DRAWN	APPROVED
			F.S.S.
FILE NO.			SHEET 23 OF 28

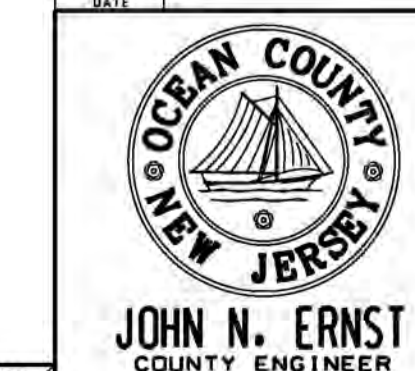

JOHN N. ERNST
COUNTY ENGINEER

ADA23
ADA23

P.E. No. 33347